



SDG 5:

Precast Prestressed Beams

Chapter 5

Tennessee Department of Transportation December 8, 2023



Table of Contents

Table of Contents	3
Table of Figures.....	4
List of Tables	5
Section 1 Design Requirements and Guidelines	1
5-101.00 Design Specifications.....	1
5-102.00 Haunch Depth	1
5-103.00 Design Loads	2
5-104.00 Concrete Compressive Strength	3
5-105.00 Prestressing Strand Stress Limits.....	3
5-106.00 Deflection.....	3
5-107.00 Prestressing Strand Size and Type.....	3
5-108.00 Tension Reinforcement	4
5-109.00 Beam Length Adjustments.....	4
5-110.00 Diaphragms	4
5-110.01 Intermediate Diaphragms	5
5-110.02 Continuity Diaphragms.....	5
5-111.00 Transforming Strands.....	6
5-112.00 Bond Breaks	6
5-113.00 Draping Strands	7
5-114.00 Dead Load Correction Curve	7
5-115.00 Allowable Tensile Stress at Beam Ends	8
Section 2 Leap Bridge Concrete	8
5-201.00 Leap Bridge Concrete Input Parameters.....	8
5-201.01 Project Tab	8
5-201.02 Geometry Tab	8
5-201.03 Materials Tab	9
5-201.04 Loads Tab	9

5-201.05 Analysis Tab	10
5-301.00 Beam Rating	20
5-401.00 Repair of Damaged Beams	20
Appendix A. Beam Properties	21
Appendix B. Standard Beam Details	25

Table of Figures

Figure 1. K-Bars	2
Figure 2. Plan View of Continuity Diaphragm	6
Figure 3. Plan View of Beam End at Abutment	9
Figure 4. Distribution Tab	11
Figure 5. Load Factors Tab	12
Figure 6. Modifier Tab	13
Figure 7. Limiting Stress Tab	14
Figure 8. Limiting Stress Factors Tab	15
Figure 9. Restraining Moments Tab	16
Figure 10. Multipliers Tab	17
Figure 11. Moment and Shear Provisions Tab	18
Figure 12. Resistance Factors/Losses Tab	19
Figure 13. Deck Tab	20
Figure 14. Bulb-Tee Beam Dimensions and Properties (6" Web)	21
Figure 15. Bulb-Tee Beam Dimensions and Properties (8" Web)	22
Figure 16. Wide Bulb-Tee Beam Dimensions and Properties	23
Figure 17. I-Beam Dimensions and Properties	24
Figure 18. Standard Details for Prestressed Bulb-Tee Beams (6" Web)	26
Figure 19. Standard Details for Prestressed Bulb-Tee Beams (8" Web)	27
Figure 20. Standard Details for Prestressed Wide Bulb-Tee Beams	28
Figure 21. Standard Details for Prestressed I-Beams	29
Figure 22. Standard Details for Prestressed Box Beams	30

List of Tables

Table 1. Intermediate Diaphragm Requirements5
Table 2. Version History and Revision Summary31

Section 1 Design Requirements and Guidelines

Precast prestressed concrete beams are economical, durable, and can be adapted to accommodate a variety of geometries, including curved and tapered bridges. They are TDOT's beam of choice for spans generally between 30 ft. and 160 ft.

5-101.00 Design Specifications

Use the current edition of the AASHTO LRFD Bridge Design Specifications. AASHTO references in this document are given in parentheses.

5-102.00 Haunch Depth

The thickness of the haunch given on the "Typical Cross-Section" drawings is always the value at the substructure locations. The thickness naturally varies within the span, but should be set to never be less than the following minimum values:

- 1" minimum at edge of flange for all beams
- 1 ½" minimum at centerline of I-beams and box beams
- 2" minimum at centerline of bulb-tee and wide bulb-tee beams

Sag vertical curves usually result in the haunches being thicker at the supports in order to not violate the minimum haunch thickness along the span.

Prestressed concrete beams used for horizontally curved bridges act as chords to concentric arcs. This results in an offset between the actual beam location (chord) and its theoretical arc. The haunch depth must be increased for this effect.

The 1-inch minimum thickness along the edge of the top flange makes provision for a 1" thick bituminous fiberboard deck panel support and provides a contingency against encroachment of the beam into the bottom of the deck. (The terms "deck" and "slab" are used interchangeably in this document.)

For haunches exceeding 2", the standard 5" stirrup projection shall be increased to ensure the stirrups project above the bottom mat of slab reinforcement or project above the top of the prestressed concrete deck panels. If the haunch is increased above 2" during construction after the beams have been fabricated, the haunch will require supplemental reinforcement (K-bars) to sufficiently engage the slab reinforcement with the stirrups. If the haunch depth varies significantly between spans or even within a span, the stirrup projections or K-bar vertical leg lengths will need to vary accordingly and be called out on the bridge plans.



Figure 1. K-Bars

5-103.00 Design Loads

HL-93 loading is the design live load. (3.6.1.2)

- For single span bridges, use design lane, design truck, and design tandem.
- For multi-span bridges, use design lane, design truck, design tandem, and double truck.
 - Do not use double tandem unless permission is given by the Design Manager. It is rarely necessary.

Prior to the curing of the deck, all loads act on a simply supported, non-composite beam section. The non-composite loads include:

- Dead load of the beams, slab, haunches, intermediate diaphragms, and deck forms (or panels). These are designated as DC₁.
 - Lightweight concrete for the deck is an option with the Directors' approval. See AASHTO 5.4.2.8. Lightweight concrete (Class L) is seldom used and is more expensive than Class D and Class DS concrete. It can be helpful when there is a special need to reduce the slab weight, including reducing the weight of the superstructure for seismic design.
- After the deck is cured, all additional loads act on the composite section (beam, deck, and haunch) and act on continuous spans. The composite loads include:
 - Live Load (LL)
 - Dead Load of parapets, sidewalks, median barriers, and any other dead load component added after the slab is cured (DC₂)
 - Dead Load of wearing surface and utilities (DW) (The wearing surface load is 35 psf.)
 - Utility loads shall be applied as a line load and include the weight of the pipe and full volume in the pipe. Hanger spacing shall be designed and specified by the utility but shall not exceed 10 feet.

5-104.00 Concrete Compressive Strength

- Use the lowest compressive strengths that satisfy the beam design requirements for the initial and final beam strengths. The minimum compressive strengths shall be 5 ksi (final) and 4 ksi (release).
- No compressive strengths above 10 ksi will be allowed. This is the upper limit because TDOT does not have confidence in the aggregate performing adequately at strengths above 10 ksi.
- Specify f'_{ci} and f'_c of the beam to the nearest 0.1 ksi. $f'_{c\text{slab}} = 4$ ksi

5-105.00 Prestressing Strand Stress Limits

For prestressed concrete beams, use low-relaxation (low-lax) strands pulled to 75 percent of the tensile strength of the strand (Table 5.9.2.2-1).

Strands must all be pulled to the same force for any given beam. Partial prestressing of strands is prohibited, except when two strands are added to the top of a beam as an aid to the fabricator to support the reinforcement cage. Do not show these strands on the bridge plans. If used, they shall be shown on the beam shop drawings from the fabricator. These strands shall not be pulled to more than 5 kips each without the Design Manager's approval.

All prestressed beams shall have at least one strand in each corner of the bottom flange. The corner strands shall be placed 2 inches from each vertical face of the bottom flange. This strengthens the corners of the bottom flange and helps prevent concrete spalling, especially during shipping, handling, and erection.

5-106.00 Deflection

All beams must have upward deflection under total dead load ($DC_1 + DC_2 + DW$). All deflection multiplier factors in Leap Bridge Concrete shall be set to 1.0.

5-107.00 Prestressing Strand Size and Type

Use 6/10" diameter low-lax strands unless directed otherwise by the Design Manager. The use of 1/2" diameter strands may be permitted in special cases with approval of the Design Manager.

Strands must all be the same size for any given beam, except the two partially prestressed strands added to the top of the beam to support the stirrups. These partially prestressed strands shall not be less than 3/8" in diameter.

5-108.00 Tension Reinforcement

All prestressed beams shall have mild reinforcement placed in the top of the beams. The required area of reinforcement is the greater of 1.2 multiplied by the cracking moment ($1.2M_{cr}$) or the area required by Leap Bridge Concrete. Use $f_{cpe} = 0$ and $S_c = S_{nc}$ when computing M_{cr} for this particular design requirement. In most cases, the area of reinforcement required for $1.2M_{cr}$ will exceed the area required by Leap Bridge Concrete, which is based on the actual tensile stress in the top of the beam. However, the extra reinforcement provides additional strength that helps protect the beam from overstresses and damage during shipping and erection. The mild tension reinforcement shall be symmetrical about the centerline of the beam.

5-109.00 Beam Length Adjustments

Beam lengths shall be increased to account for the vertical profile of the bridge as necessary. All beam lengths shall be rounded up to the nearest inch.

5-110.00 Diaphragms

Permanent support or end diaphragms are always required between all beams at substructure locations. Intermediate diaphragms between all beams shall be required as given in Table 1. Support diaphragms at bents and piers shall be 1'-6" thick.

5-110.01 Intermediate Diaphragms

Use intermediate diaphragms as required in Table 1 below.

Bulb-Tee and Wide Bulb-Tee Beams	
Span	Diaphragm Requirement
$L < 40'$	none
$40' \leq L < 80'$	midspan
$L \geq 80'$	third points along span
I-Beams	
Span	Diaphragm Requirement
$L \geq 80'$	midspan
$R \leq 800'$	midspan
L = span length	
R = radius of curvature	

Table 1. Intermediate Diaphragm Requirements

Standard drawing STD-14-1 specifies structural steel intermediate diaphragms for bulb-tee and wide bulb-tee beams. Standard drawing STD-14-2 specifies cast-in-place concrete diaphragms for I-beams but allows the use of steel channels as an alternate.

5-110.02 Continuity Diaphragms

TDOT uses jointless, continuous bridges whenever possible. Continuity diaphragms are required at the bents of continuous bridges because they facilitate moment transfer between spans.

The continuity diaphragm shall be detailed for a positive moment connection with slab reinforcement and bent prestressing strands in the bottom row of the beam ends threaded through horizontal stirrups, all encased in the diaphragm.

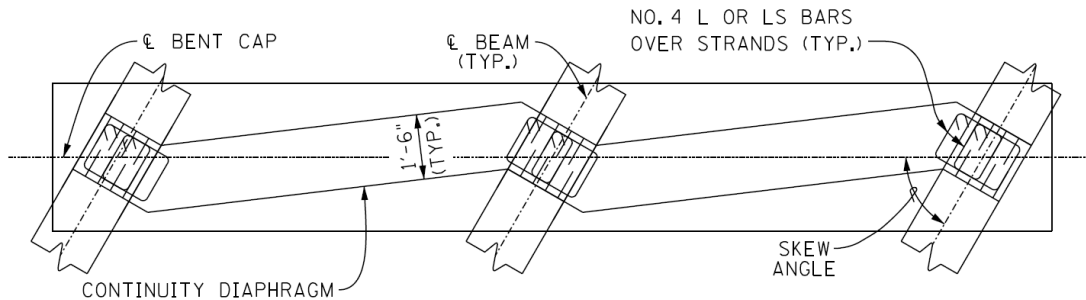

Figure 2. Plan View of Continuity Diaphragm

AASHTO 5.12.3.3.9 only allows fully bonded strands to be embedded in the diaphragms. Verify this is satisfied when checking the beam shop drawings.

The following strategies are in place to allow end rotation of the beam prior to continuity, to avoid calculating restraint moments, to help reduce cracking in diaphragms/endwalls, and to enhance continuity:

1. 90 days after detensioning is the earliest time a beam can receive a full depth continuity diaphragm. If the beams are placed on supports before this time, only the bottom 15 inches of the diaphragm shall be poured (see plans note 116). The remainder of the diaphragm is poured when the slab over the support is poured. Any deviation from this requirement will require the Director's approval.
2. Pouring the bottom 15 inches of the continuity diaphragm immediately after the beams are erected helps stabilize the ends of the beams and prevents thermally induced movement of the beams relative to the supports. This movement could otherwise result in misalignment of the beams and damage to the elastomeric bearing pads. The beams are still able to rotate slightly when the slab is poured.
3. The Contractor shall provide temporary bracing until the diaphragms are poured and cured.

The office policy is to assume that prestressed concrete beams are continuous for composite dead load and live load once the slab and support diaphragms have cured.

5-111.00 Transforming Strands

Transformed strands are not permitted for prestressed beam design.

5-112.00 Bond Breaks

When bond breaks (aka debonding, shielding, or wrapping strands) are required for a design, AASHTO's requirements (5.9.4.3.3) shall be satisfied with the following exceptions:

1. Bond breaks shall not be used on vertically or horizontally adjacent strands or corner strands in the bottom row.
2. The office policy exception for rows above the bottom row is to try to avoid placing bond breaks on the exterior strands. However, if that cannot be avoided, the shortest possible bond breaks shall be used for exterior strands above the bottom row.

5-113.00 Draping Strands

Draping (aka harping, deflecting, or raising) strands permits the designer to extend the span limits of prestressed beams by reducing the tensile stresses near the top ends of the beams.

Draping strands should only be done if the maximum number of bond breaks has been reached and there are still tensile overstresses in the top of the beam near the ends. Use the following limits when draping strands:

- Maximum allowable total hold-down force = 50 kips
- Maximum allowable strand hold-down force = 5 kips per strand
- Maximum number of draped strands = 10 for I-beams and bulb-tee beams (6" web)
= 15 for bulb-tee (8" web) and wide bulb-tee beams
- Hold down points shall be between 0.3L and 0.4L from each end of the beam where L is the precast beam length. Moving the hold-down points toward the ends of the beam can gain capacity in the beam but increases the hold-down force.

5-114.00 Dead Load Correction Curve

Show the dead load correction curve at the quarter points of each span. Use the dead load deflection of the slab, haunch, and composite dead load to calculate the dead load correction values. Do not include any dead load deflection due to the self-weight of the beam or the intermediate diaphragms.

After the beams are erected, the contractor will conduct a field survey to establish the as-erected profile of each beam. The expected final top of beam profile is then calculated by reducing the as-erected beam profile by the values given in the dead load correction curve. The required bottom of slab profile is determined by subtracting the slab thickness from the required top of slab profile based on the finished grade line. The elevation difference between the bottom of slab and the top of beam is the haunch thickness. If the beams have excessive camber, then the grade may have to be raised to provide the minimum haunch thickness. Occasionally beams do not camber as much as expected, and the haunch must be increased to maintain the final profile

of the deck. Adjustments to the grade and haunch are made by adjusting the elevations of the deck forms and bridge screed rail.

5-115.00 Allowable Tensile Stress at Beam Ends

The Service III tensile stress limit at the bearing and transfer locations shall be taken as $0.24\sqrt{f'c}$. The Service III tensile stress limit at all other locations shall be taken as $0.19\sqrt{f'c}$.

Section 2 Leap Bridge Concrete

Use Leap Bridge Concrete for prestressed beam design unless approval to use an alternate program is given by the Director.

5-201.00 Leap Bridge Concrete Input Parameters

5-201.01 Project Tab

- Use LRFD-9 design code
- Use Multi-Span (Continuous) span type for multi-span bridges.
- Use Simple Span for single span bridges

5-201.02 Geometry Tab

- Curb width is measured to the bottom of the parapet. See the standard drawing for the parapet to determine the width of the bottom of the parapet.
- Deck Thickness = 8.25" for most bridges
 - 8.25" is the minimum thickness allowed.
 - See SDG 4 for more information on slab thickness.
- Add 1" of sacrificial deck thickness. This will help account for the extra concrete used when steel stay-in-place deck forms are used.
- Haunch Thickness: Input the haunch thickness as shown on the typical cross-section of the superstructure.
- Select "Ignore Haunch for Comp. Section Properties".
- Precast length = Release length
- Pier to Pier = Span length
- The skew angle for Leap Bridge Concrete and the AASHTO LRFD Bridge Design Specifications is the complementary angle of the skew angle shown on the preliminary layout.
- Pier CL to Precast (For span 1, "Pier CL" is the beginning of bridge.)
 - Span 1: $\frac{1.5ft.}{\sin \theta} + \frac{\text{maximum flange width}/2}{\tan \theta}$ for I-beams, bulb-tee beams, and wide bulb-tee beams.

- Per STD-14-1, the top flange of bulb-tee and wide bulb-tee beams may be clipped for skews less than 75 degrees.
- Box beams may have their ends skewed between 60 degrees and 90 degrees, so the equation varies based on the skew angle.
- All other spans: 0.75 ft. (regardless of skew angle or beam type)

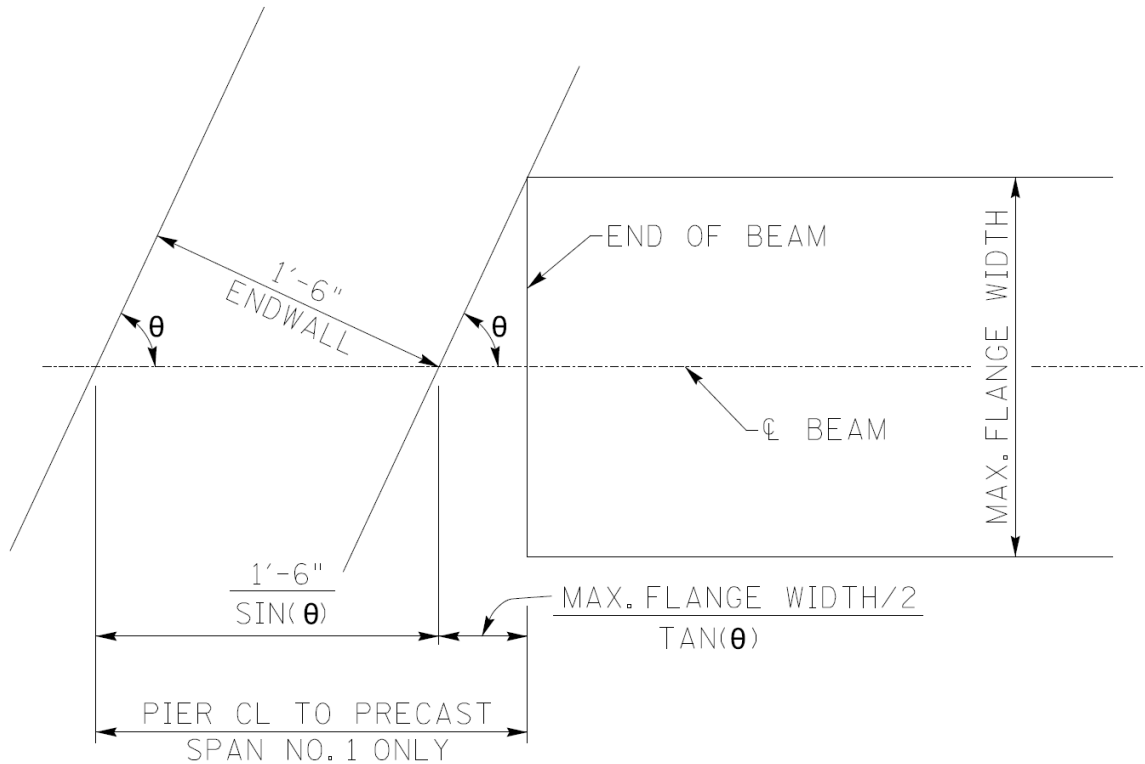

Figure 3. Plan View of Beam End at Abutment

5-201.03 Materials Tab

- Use $f'_c = 4$ ksi for the deck concrete.
- Do not transform the prestressing strands or rebar.
- Use 0.6"-270K-LL strands for most bridges.
 - ½"-270K-LL strands may be permitted in special cases with approval of the Design Manager.
- Maximum auto-debonding percentage:
 - Use current AASHTO limits.

5-201.04 Loads Tab

- Loads may be manually input or auto-generated with the wizard.
- Live Load
 - Design Lane
 - Design Tandem

- Design Truck
- Double Truck (for multi-span bridges)
- Do not use Double Tandem (unless for a special case and permission is given by the Design Manager.)
- Do not include:
 - Static live load for RSA (used for seismic design)
 - Temperature load
 - Pedestrian live load
 - Vehicular live load is to be placed from curb-to-curb, even when sidewalks or greenways are present.
 - Live load deflection
- Do not select “Mass for RSA” or “Include Static LL for RSA.

5-201.05 Analysis Tab

The following screenshots are from the Analysis Factors and Design Parameters in Leap Bridge Concrete. AASHTO references and notes are shown where applicable.

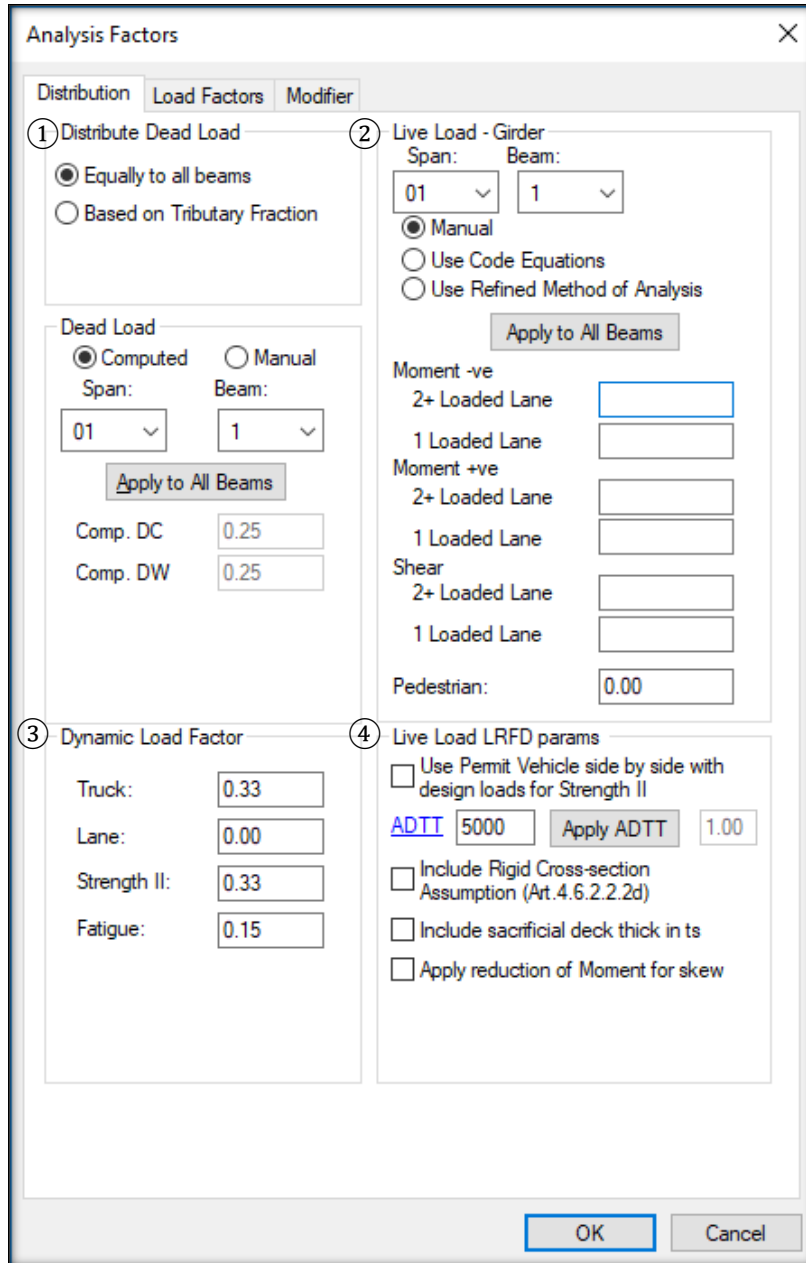

Figure 4. Distribution Tab

① Check conditions in 4.6.2.2.1.

② Use the spreadsheet "LLDF_LRFD_(current edition)" or an alternate file/program/technique approved by the Design Manager to determine the highest LLDF values for moment and shear for the entire bridge. Manually input the highest factors and apply to all beams in all spans. All beams in each span shall have the same strand and stirrup pattern unless an exception is given by the Design Manager.

③ Table 3.6.2.1-1

④ Do not apply any of the Live Load LRFD Parameters options.

Analysis Factors

Distribution | **Load Factors** | Modifier

Strength Limit State

① Strength I

		Max.	Min.
DC		1.25	0.90
DW		1.50	0.65
Live		1.75	

Included

Service Limit State

Service III

		Max	Min.
DC		1.00	1.00
DW		1.00	1.00
② Live		1.00	

Included

Fatigue I Limit State

Live

③ [Load Factors](#)

1.75

Included

OK Cancel

① Do not use Strength II for new bridges. It is for permit loads.

② Service III live load factor = 1.0 when using the refined method of prestress losses.

③ See Table 3.4.1-1 for load factors.

Figure 5. Load Factors Tab

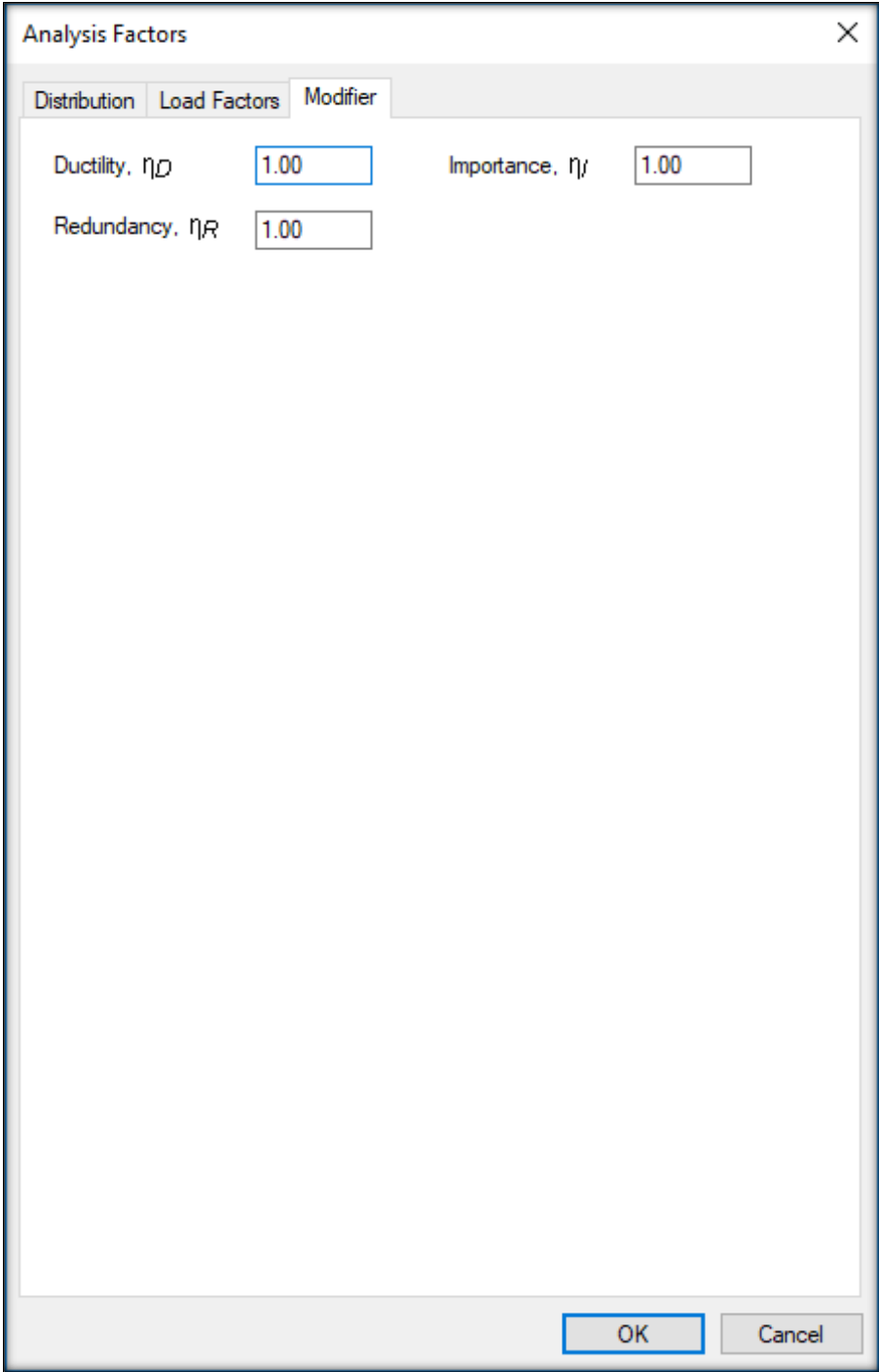

Office policy

See 1.3.3, 1.3.4, and 1.3.5.

Figure 6. Modifier Tab

Project Design Parameters [X]

Resistance Factor/Losses		Moment and Shear Provisions	
Limiting Stress		Restraining Moments	
Temporary Before Losses			
Compression:	<input type="text" value="4.55"/>	ksi	
Tension-Precast Top:	<input type="checkbox"/>	Use Advanced Settings	...
With Reinforcement:	- <input type="text" value="0.63"/>	ksi	
No Reinforcement:	- <input type="text" value="0.20"/>	ksi	(≤ 0.20)
<input type="checkbox"/> Check at lifting point			
At Service Limit State			
Compression (Service I):	Precast		
Final1 (P/S+DL+LL):	<input type="text" value="5.40"/>	ksi	
Final2 (P/S+DL):	<input type="text" value="4.05"/>	ksi	
Compression (Fatigue I)			
Final3 (0.5[P/S+DL]+F_LL):	<input type="text" value="3.60"/>	ksi	
Tension (Service III) (≤ 0.60) -	<input type="text" value="0.57"/>	ksi	
<input type="checkbox"/> Compute stresses at top of deck			
<input checked="" type="checkbox"/> Use factor to calculate			
<input type="button" value="Edit Factors..."/>			
<input type="button" value="OK"/>		<input type="button" value="Cancel"/>	

Values will vary based on concrete strength.

Figure 7. Limiting Stress Tab

Limiting Stress Factors [X]

① Temporary Stresses Before Losses

Compression: x f'ci

② Tension-Precast Top: ...

With Reinforcement: - x sqrt (f'ci)

No Reinforcement: - x sqrt (f'ci)

Stresses At Service Limit State

③ Compression (Service I): Precast

Final1 (P/S+DL+LL): x f'c

Final2 (P/S+DL): x f'c

④ Compression (Fatigue I):

Final3 (0.5[P/S+DL]+F_LL): x f'c

⑤ Tension (Service III): - x sqrt (f'c)

① 5.9.2.3.1a

② Table 5.9.2.3.1b-1

③ Table 5.9.2.3.2a-1

④ 5.5.3.1

⑤ Table 5.9.2.3.2b-1

Figure 8. Limiting Stress Factors Tab

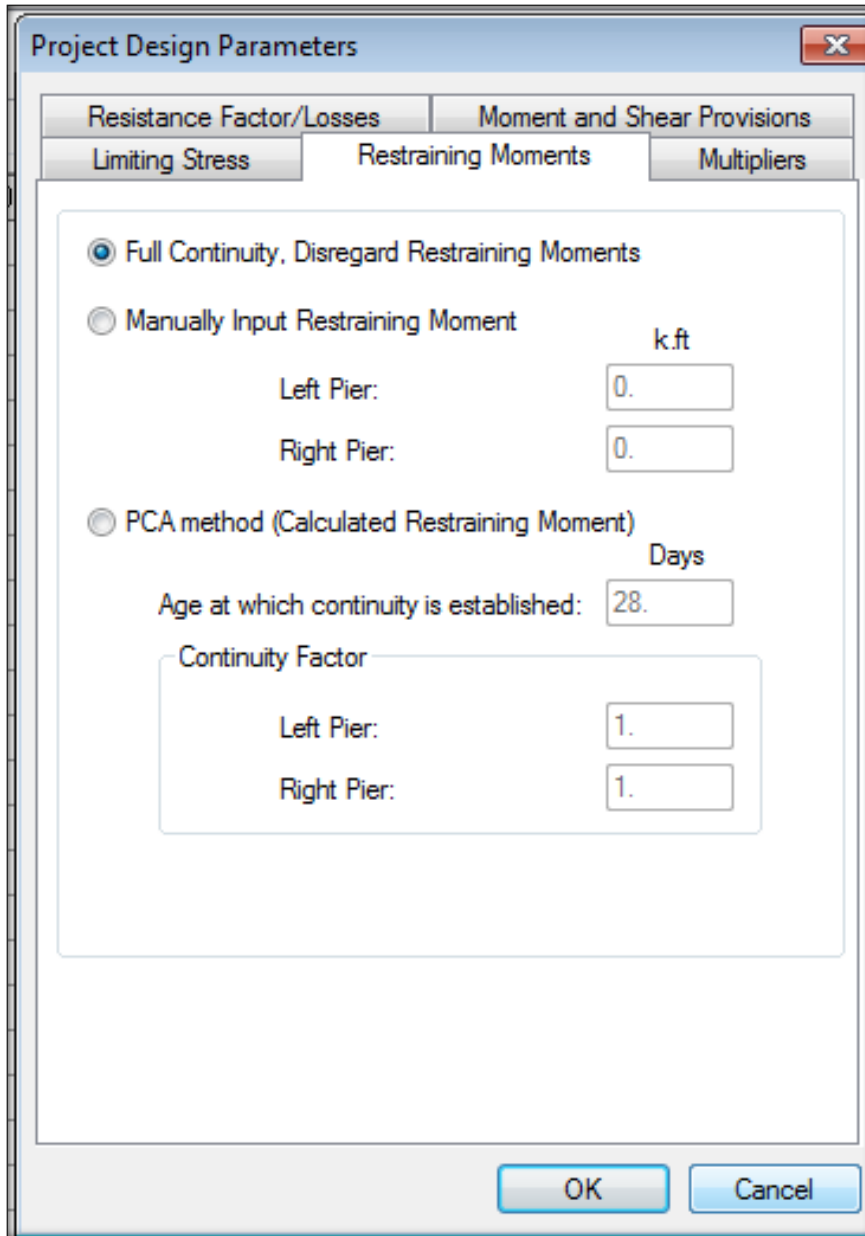

Office policy

Ensure that standard plan notes 116 and 153 are included in the contract bridge plans.

Figure 9. Restraining Moments Tab

Project Design Parameters [X]

Resistance Factor/Losses		Moment and Shear Provisions	
Limiting Stress		Restraining Moments	
		Multipliers	
① Deflection Multipliers			
		No Topping	With Topping
Erection:			
Self Weight:	<input type="text" value="1"/>	<input type="text" value="1"/>	<input type="text" value="1"/>
Prestress:	<input type="text" value="1"/>	<input type="text" value="1"/>	<input type="text" value="1"/>
Final:			
Self Weight:	<input type="text" value="1"/>	<input type="text" value="1"/>	<input type="text" value="1"/>
Prestress:	<input type="text" value="1"/>	<input type="text" value="1"/>	<input type="text" value="1"/>
SDL:	<input type="text" value="1"/>	<input type="text" value="1"/>	<input type="text" value="1"/>
Deck Weight:			<input type="text" value="1"/>
Length Multipliers			
		Transfer	Development
② Bonded:	<input type="text" value="1"/>	<input type="text" value="1.6"/>	<input type="text" value="1.6"/>
③ Debonded:	<input type="text" value="1"/>	<input type="text" value="2"/>	<input type="text" value="2"/>
<input type="checkbox"/> Span to Depth Ratio Check (Table 2.5.2.6.3-1)			
		<input type="button" value="OK"/>	<input type="button" value="Cancel"/>

- ① Office policy
- ② 5.9.4.3.2
- ③ 5.9.4.3.3

Figure 10. Multipliers Tab

Office policy

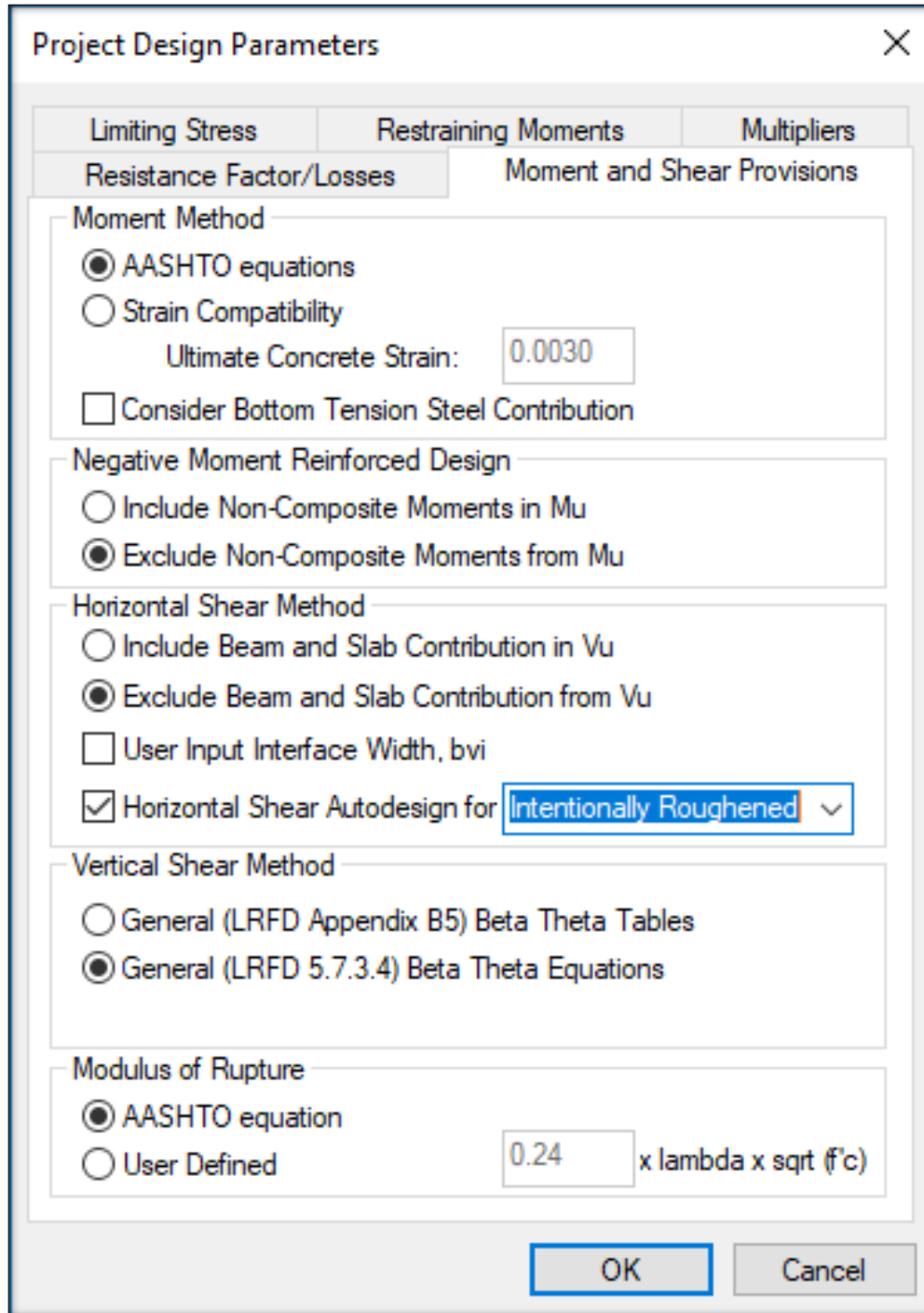

Figure 11. Moment and Shear Provisions Tab

Project Design Parameters [X]

Limiting Stress Restraining Moments Multipliers

Resistance Factor/Losses Moment and Shear Provisions

Strength Reduction Factors, Phi

Reinforced:		Prestressed:		Shear:
Tens:	Comp:	Tens:	Comp:	
① 0.90	0.75	1.00	0.75	0.90

Strain Limits

Prestressed, all fy values [v]

② Compression--> 0.0020 <--Transition--> 0.0050 <--Tension

Prestress Losses

AASHTO % Manual %

③ Relative Humidity: 70.00 Days Release: 10.00 %

④ Release Time (ti): 0.75 Final: 20.00

Age of deck placement (td): 90.00

Final Age (tf): 20000.00

Steel Relaxation

AASHTO by Tadros

⑤ KL: 30.00 [v] K'L: 45.00 [v]

Compute Losses using

Approximate Method ⑥ Refined Method

Pre '2005 Interims' LRFD spec Neglect Elastic Gains

Compute ES using Eq. C5.9.3.2.3a

OK Cancel

- ① 5.5.4.2
- ② 5.6.2.1
- ③ 70%.
- ④ 90 days
- ⑤ 5.9.3.4.2c
- ⑥ Refined Method

Figure 12. Resistance Factors/Losses Tab

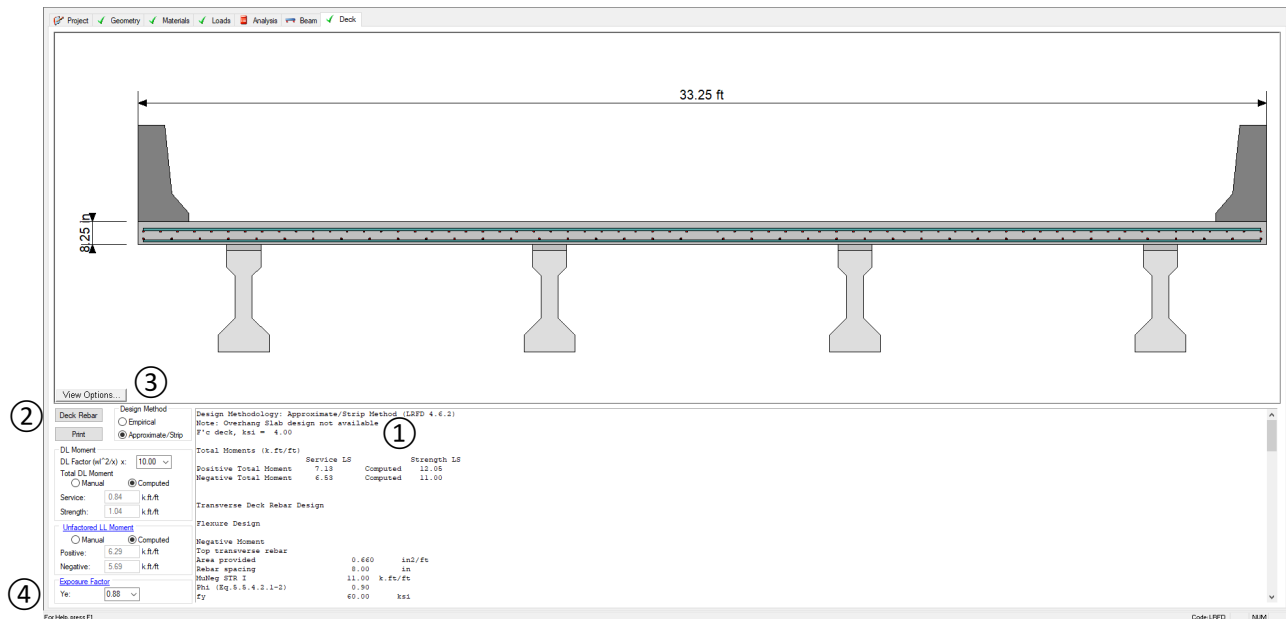

Figure 13. Deck Tab

- ① Leap Bridge Concrete does not consider the cantilever in its slab design, so the designer must check the cantilever to see if it controls.
- ② “Longitudinal Deck Rebars” under the “Deck Rebar” tab are not the longitudinal negative moment continuity bars. Only top longitudinal shrinkage and temperature reinforcement and bottom longitudinal distribution reinforcement are checked here.
- ③ Use the Approximate/Strip method. (4.6.2)
- ④ Office policy is to use a maximum allowable crack width of 0.015”, which corresponds to an exposure factor $\gamma_e = 0.88$. This value can be manually input. (5.6.7)

5-301.00 Beam Rating

All new beam designs shall be rated using the *AASHTOWare Bridge Rating* program. Contact the Design Manager for the current office policy regarding bridge rating.

5-401.00 Repair of Damaged Beams

When a beam is damaged during fabrication, shipping, or erection, the contractor must submit a detailed repair procedure for review and approval. The repair procedure submittal shall include details of the repair procedure, pictures and drawings of the damaged area, and specifications of the repair material. See the current edition of the *Manual for the Evaluation and Repair of Precast, Prestressed Concrete Bridge Products* for guidance on repair procedures.

Appendix A. Beam Properties

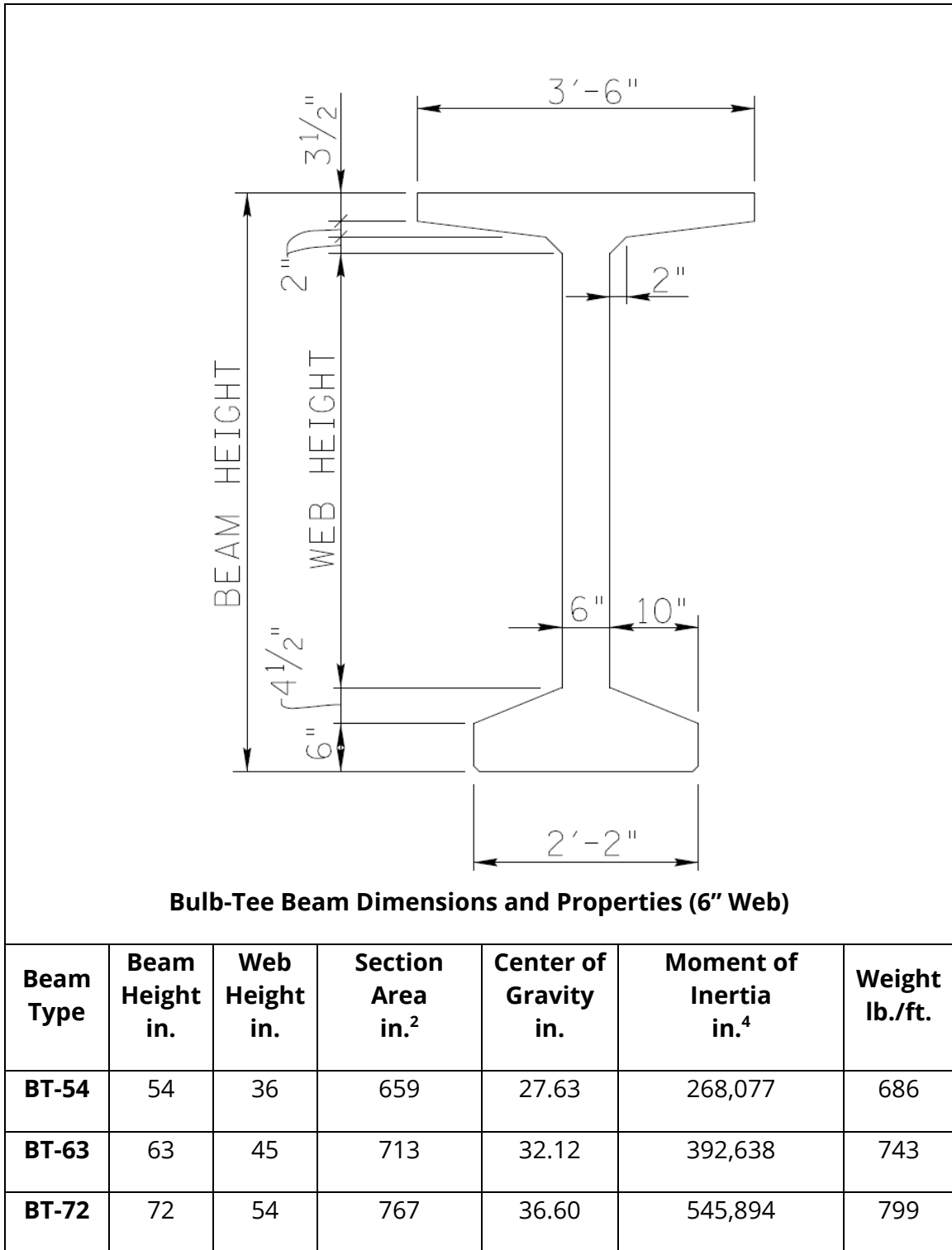

Figure 14. Bulb-Tee Beam Dimensions and Properties (6" Web)

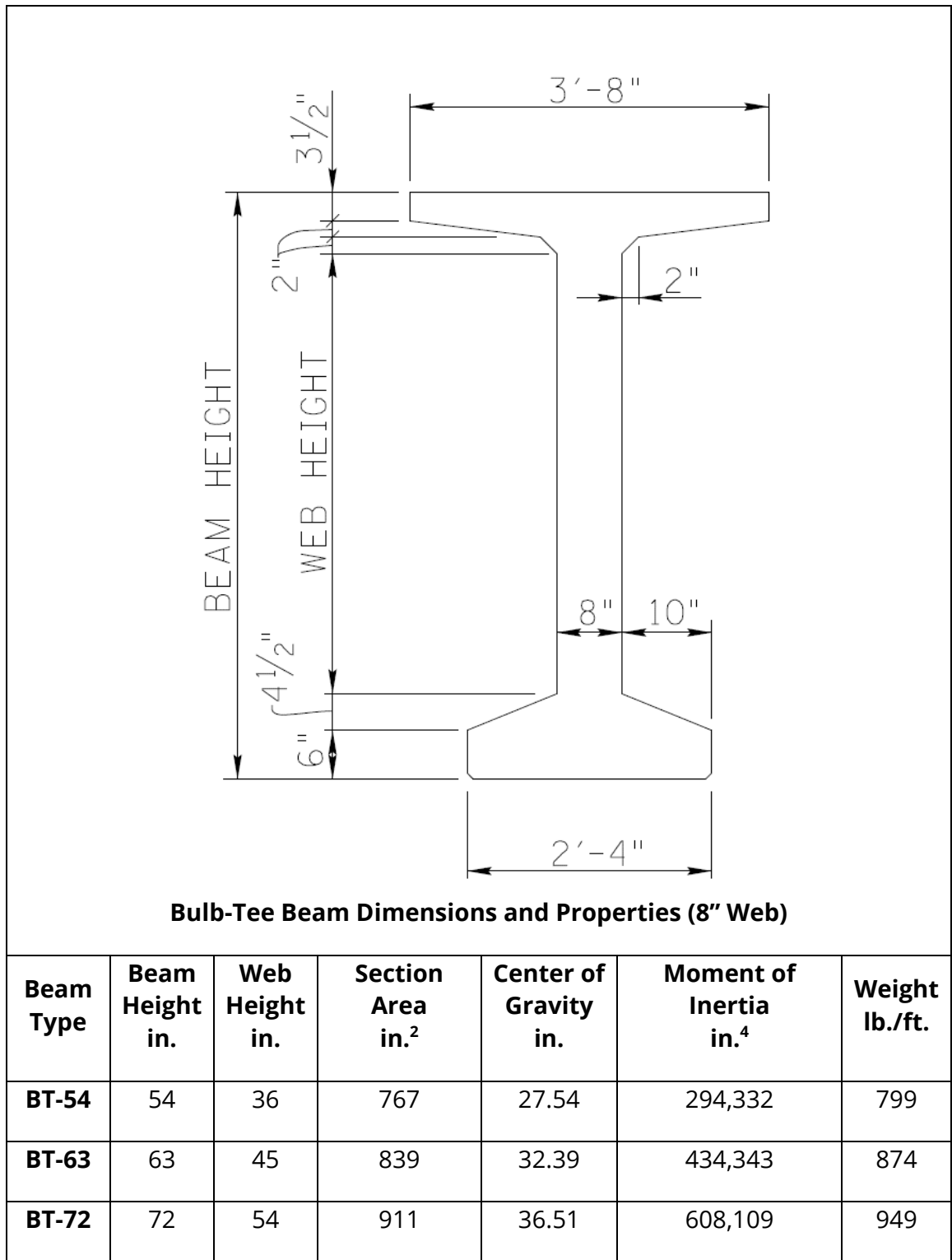

Figure 15. Bulb-Tee Beam Dimensions and Properties (8" Web)

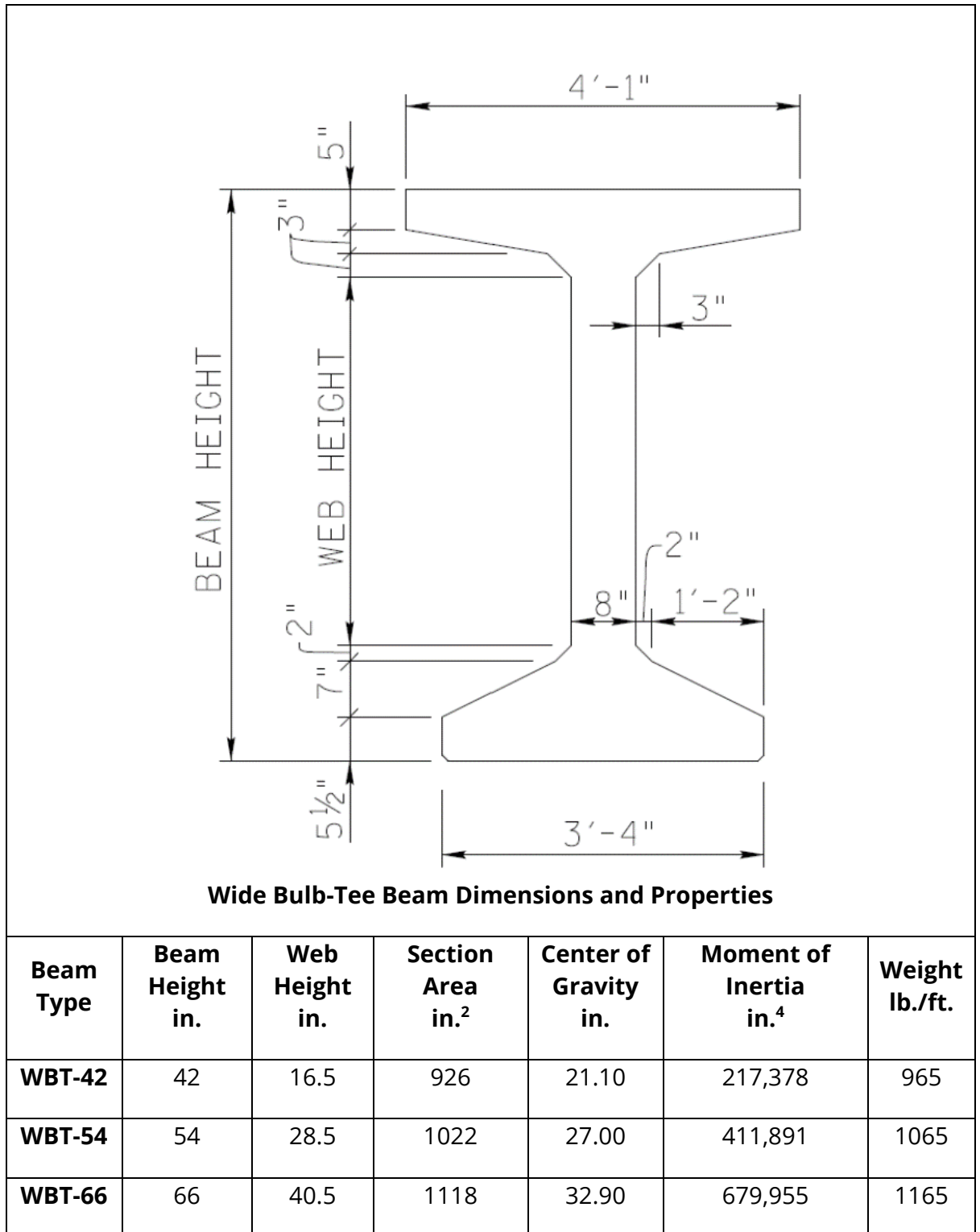
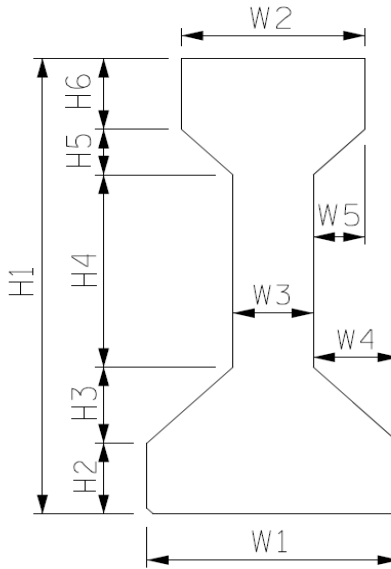

Figure 16. Wide Bulb-Tee Beam Dimensions and Properties



I-Beam Dimensions											
Type	H1	H2	H3	H4	H5	H6	W1	W2	W3	W4	W5
I	28"	5"	5"	11"	3"	4"	16"	12"	6"	5"	3"
II	36"	6"	6"	15"	3"	6"	18"	12"	6"	6"	3"
III	45"	7"	7.5"	19"	4.5"	7"	22"	16"	7"	7.5"	4.5"
IV	54"	8"	9"	23"	6"	8"	26"	20"	8"	9"	6"

I-Beam Section Properties				
Beam Type	Section Area in. ²	Center of Gravity in.	Moment of Inertia in. ⁴	Weight lb./ft.
I	276	12.59	22,750	287
II	369	15.83	50,980	384
III	560	20.27	125,390	583
IV	789	24.73	260,730	822

Figure 17. I-Beam Dimensions and Properties

Appendix B. Standard Beam Details

Appendix B contains the following standard beam details:

Figure 18. Standard Details for Prestressed Bulb-Tee Beams (6" Web)

Figure 19. Standard Details for Prestressed Bulb-Tee Beams (8" Web)

Figure 20. Standard Details for Prestressed Wide Bulb-Tee Beams

Figure 21. Standard Details for Prestressed I-Beams

Figure 22. Standard Details for Prestressed Box Beams

NOTES AND DETAILS FOR GIRDER DRAWINGS IN CONTRACT PLANS

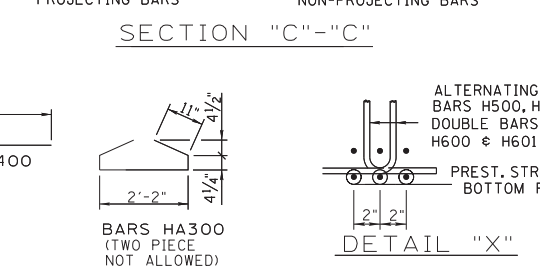
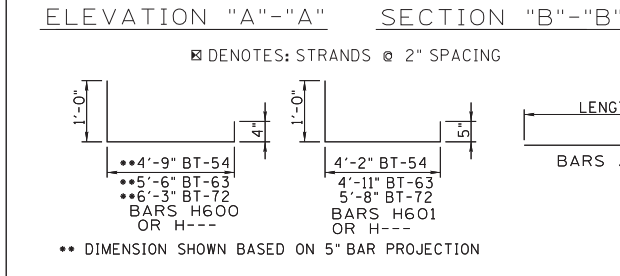
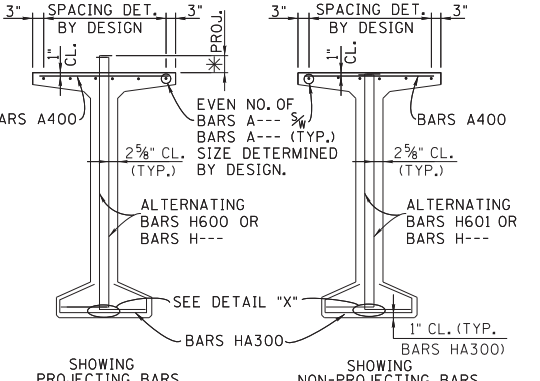
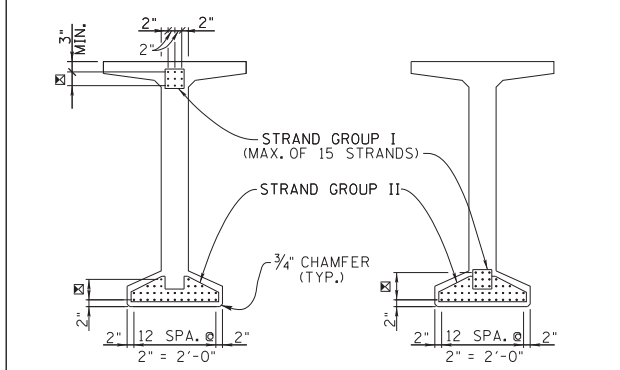
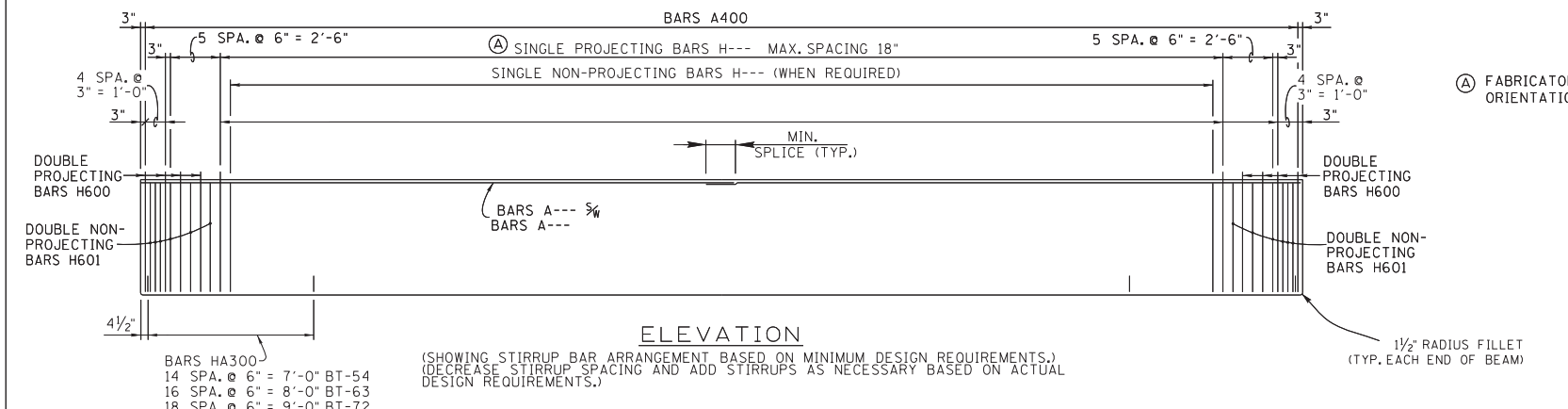
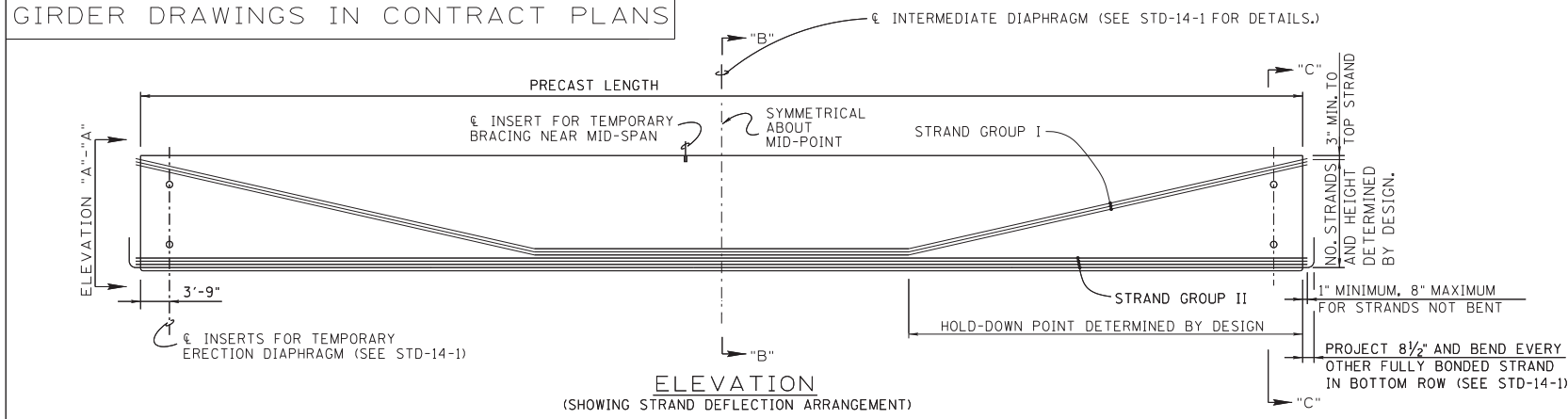

ESTIMATED QUANTITIES (PER BEAM)

NO. REQ'D	CLASS "A" CONCRETE	REINFORCING STEEL	PRESTRESSING STRANDS (LOW RELAXATION)
	C.Y.	LB.	LB.

BILL OF STEEL (PER BEAM)

BAR	SIZE	NO. REQ'D	LENGTH
A400	4		3'-4"
A500	5		5'-6"
A---			
H---			
H600	6		
H601	6		
HA300	3		4'-9"

DESIGNED BY P. MILLER/A. PRICE DATE 5/2020
 DRAWN BY P. MILLER/A. PRICE DATE 5/2020
 SUPERVISED BY T.A.K. / H. WALKER DATE 5/2020
 CHECKED BY H. WALKER DATE 5/2020

NOTES AND DETAILS FOR DESIGNERS AND DETAILERS

● RANGE FOR BARS HA300 = 1.5 X BEAM DEPTH ▶ 5.9.4.4.2

PROJECT NO.	YEAR	SHEET NO.
	2023	

REVISIONS			
NO.	DATE	BY	BRIEF DESCRIPTION

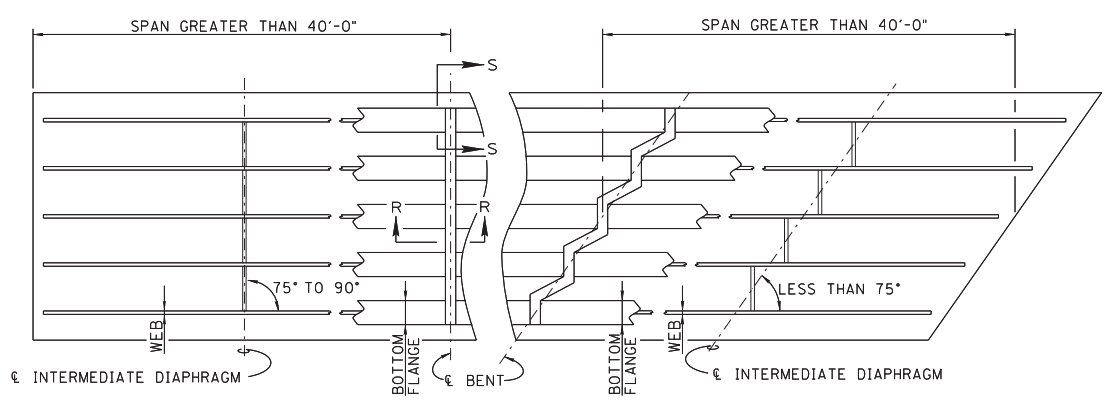

PLAN SHOWING LOCATION OF INTERMEDIATE DIAPHRAGMS

SEE SECTION 5.110.01 FOR INTERMEDIATE DIAPHRAGM LOCATION REQUIREMENTS.

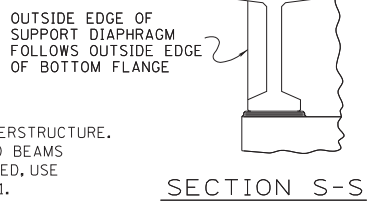
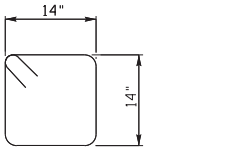
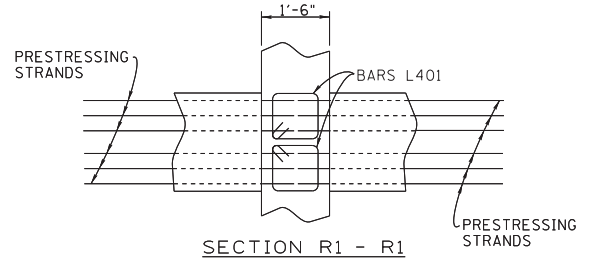
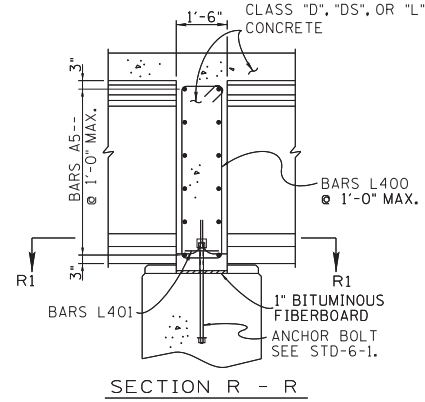

BARS L401
 LIST IN BILL OF STEEL UNDER SUPERSTRUCTURE.
 FOR CURVED BRIDGES WITH CHORDED BEAMS
 WHERE NON-SQUARE BARS ARE NEEDED, USE
 BARS LS400 INSTEAD OF BARS L401.

7-WIRE STRAND WEIGHT
 5/16" DIA. = 0.740 LB./FT.
 1/2" DIA. = 0.525 LB./FT.

CORRECT *Del A. Kravitz*
 ENGINEER OF STRUCTURES

BEAM TYPE	CONCRETE C.Y. PER/FT.	TEXTURE FINISH S.Y. PER/FT	TEXTURE FINISH S.Y. PER/FT
BT-54	0.1973	1.6478	0.9564
BT-63	0.2158	1.8144	1.0397
BT-72	0.2343	1.9811	1.1231

STATE OF TENNESSEE
 DEPARTMENT OF TRANSPORTATION
 STANDARD DETAILS
 FOR
 PRESTRESSED
 BULB-TEE BEAMS
 (8" WEB)
 2023

FIGURE 19. STANDARD DETAILS FOR PRESTRESSED BULB-TEE BEAMS (8" WEB)

NOTES AND DETAILS FOR GIRDER DRAWINGS IN CONTRACT PLANS

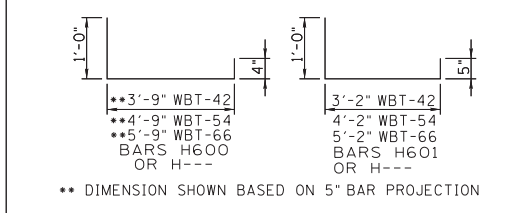
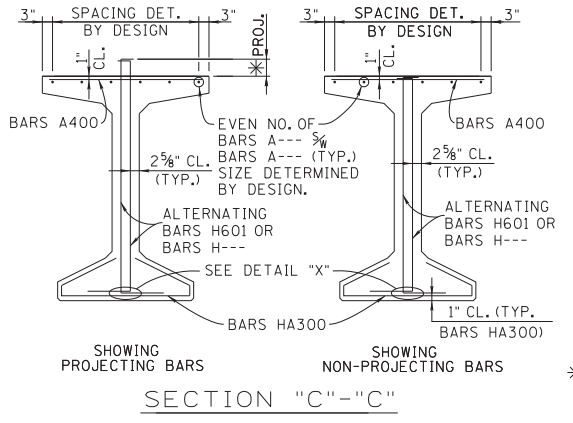
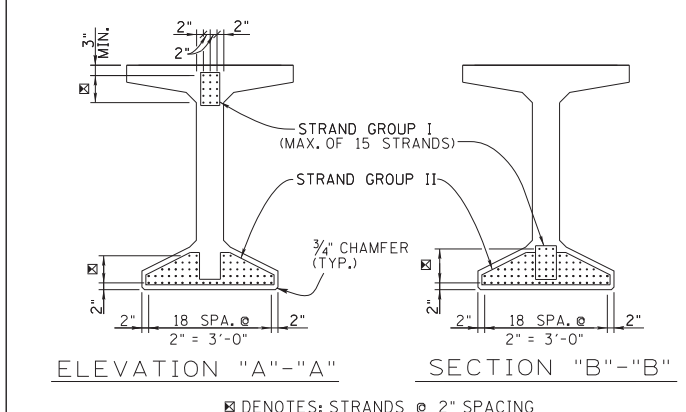
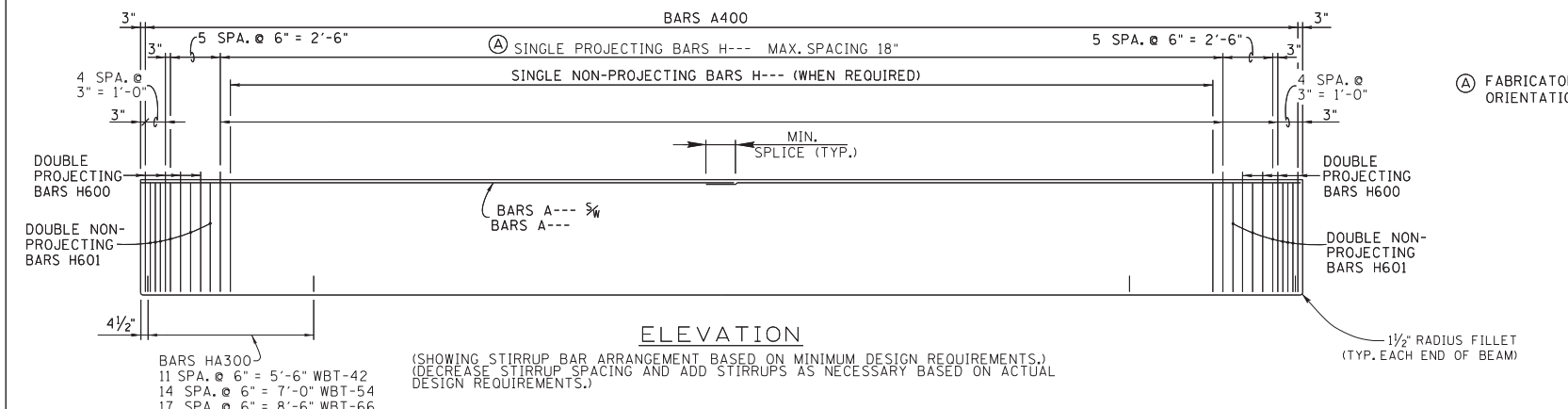
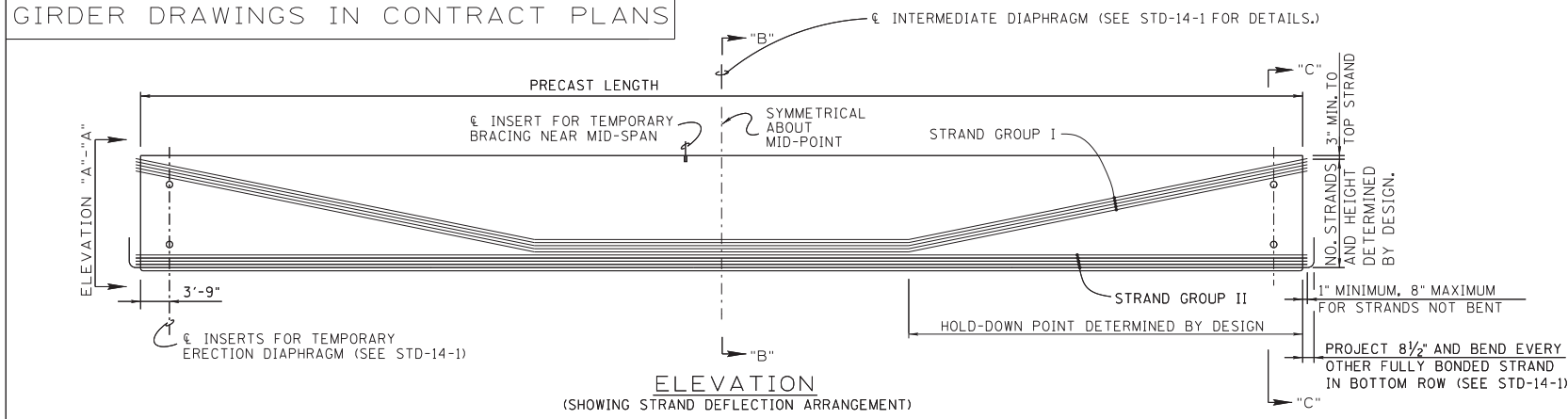

ESTIMATED QUANTITIES (PER BEAM)

NO. REQ'D	CLASS "A" CONCRETE	REINFORCING STEEL	PRESTRESSING STRANDS (LOW RELAXATION)
	C.Y.	LB.	LB.

BILL OF STEEL (PER BEAM)

BAR	SIZE	NO. REQ'D	LENGTH
A400	4	4	3'-9"
A500	5	5	5'-6"
A---			
H---			
H600	6	6	
H601	6	6	
HA300	3	3	6'-10"

DESIGNED BY P. MILLER/A. PRICE DATE 5/2020
 DRAWN BY P. MILLER/A. PRICE DATE 5/2020
 SUPERVISED BY T.A.K. / H. WALKER DATE 5/2020
 CHECKED BY H. WALKER DATE 5/2020

NOTES AND DETAILS FOR DESIGNERS AND DETAILERS

RANGE FOR BARS HA300 = 1.5 X BEAM DEPTH > 5.9.4.4.2

PROJECT NO.	YEAR	SHEET NO.
	2023	

REVISIONS			
NO.	DATE	BY	BRIEF DESCRIPTION

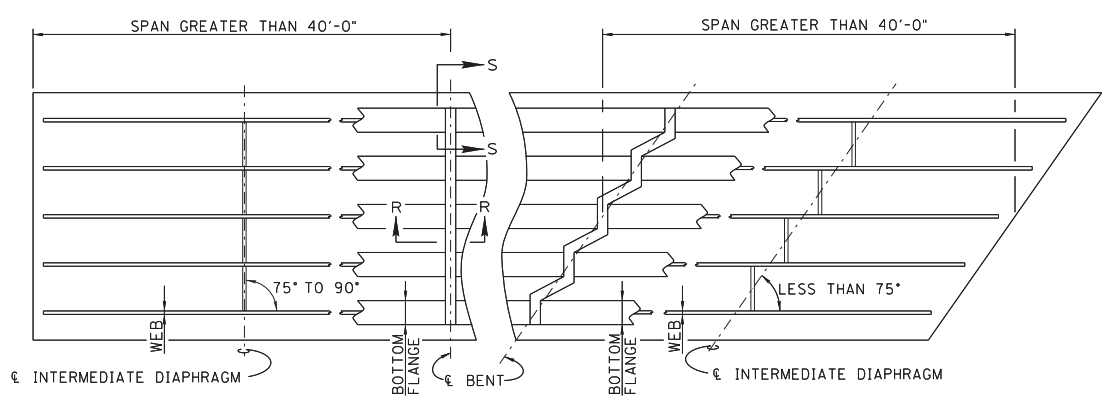

PLAN SHOWING LOCATION OF INTERMEDIATE DIAPHRAGMS

SEE SECTION 5.110.01 FOR INTERMEDIATE DIAPHRAGM LOCATION REQUIREMENTS.

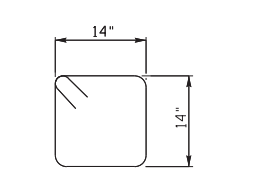
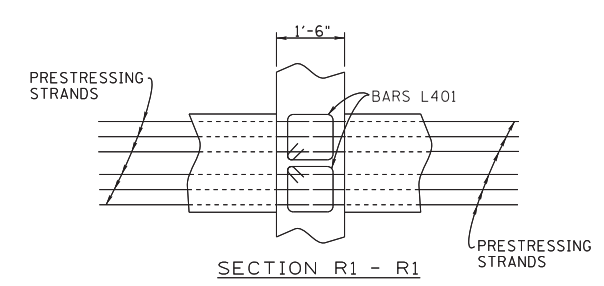
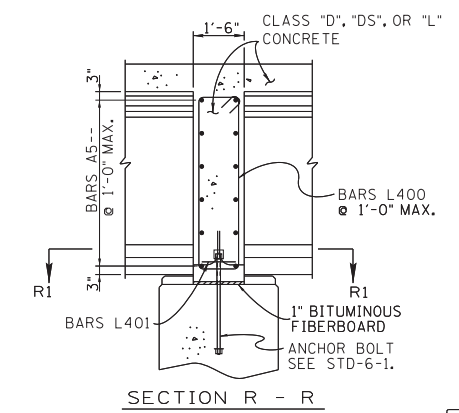

LIST IN BILL OF STEEL UNDER SUPERSTRUCTURE. FOR CURVED BRIDGES WITH CHORDED BEAMS WHERE NON-SQUARE BARS ARE NEEDED, USE BARS LS400 INSTEAD OF BARS L401.

7-WIRE STRAND WEIGHT
 5/16" DIA. = 0.740 LB./FT.
 1/2" DIA. = 0.525 LB./FT.

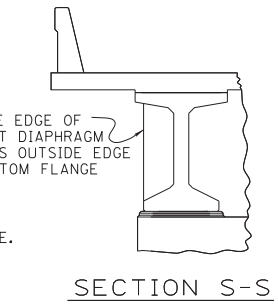

BEAM TYPE	CONCRETE C.Y. PER/FT.	TEXTURE FINISH S.Y. PER/FT	TEXTURE FINISH S.Y. PER/FT
WBT-42	0.2382	1.6118	0.9940
WBT-54	0.2629	1.8341	1.1051
WBT-66	0.2876	2.0563	1.2162

STATE OF TENNESSEE
 DEPARTMENT OF TRANSPORTATION
 STANDARD DETAILS FOR
 PRESTRESSED WIDE BULB-TEE BEAMS
 2023

CORRECT *Del A. Krueger*
 ENGINEER OF STRUCTURES

FIGURE 20. STANDARD DETAILS FOR PRESTRESSED WIDE BULB-TEE BEAMS

NOTES AND DETAILS FOR BEAM DRAWINGS IN CONTRACT PLANS

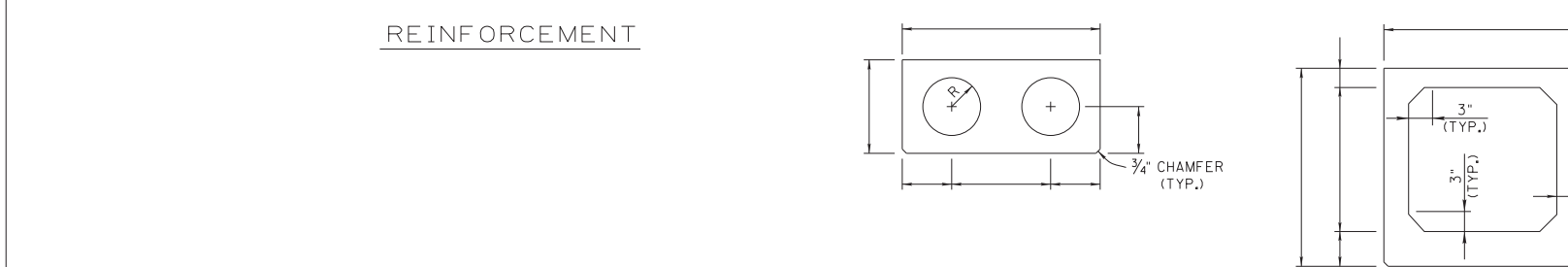
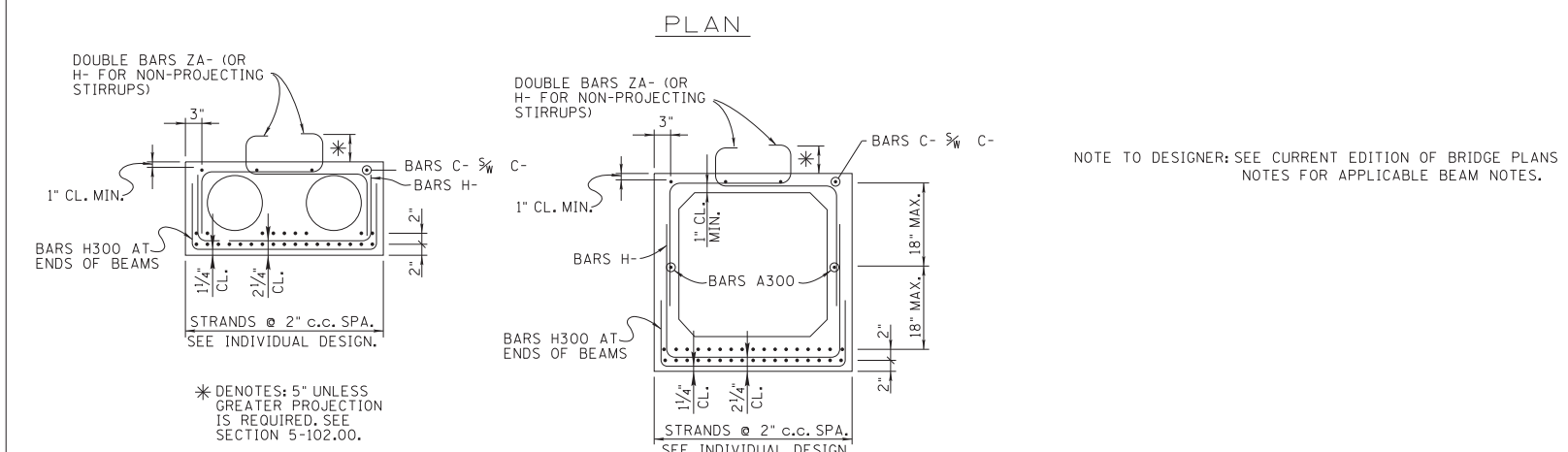
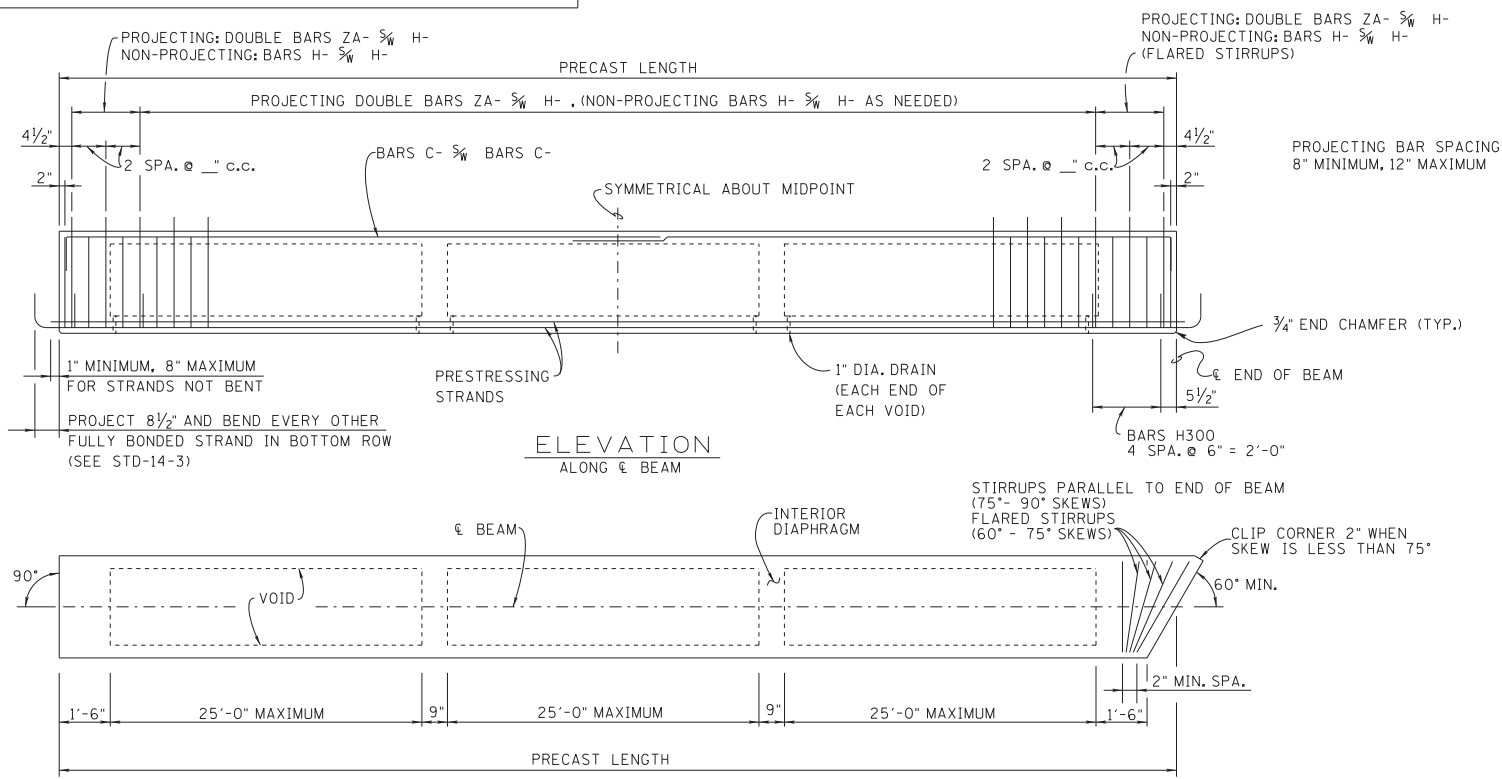

ESTIMATED QUANTITIES (PER BEAM)

NO. REQ'D.	CLASS 'A' CONCRETE C.Y.	STEEL BAR REINFORCING LB.	PRESTRESSING STRANDS (LOW RELAXATION) LB.

BILL OF STEEL (PER BEAM)

BAR	SIZE	NO. REQ'D.	LENGTH
A300	3		
A500	5		5'-6"
A501	5		
A502	5		
C-			
G-			2'-4"
H300	3	10	
H-			
ZA-			

DESIGNED BY P. MILLER/A. PRICE DATE 5/2020
 DRAWN BY P. MILLER/A. PRICE DATE 5/2020
 SUPERVISED BY T.A.K. / H. WALKER DATE 5/2020
 CHECKED BY H. WALKER DATE 5/2020

NOTES AND DETAILS FOR DESIGNERS AND DETAILERS

BEAM DIMENSIONS, STRAND PLACEMENT AND SIZE, AND SPACING OF STIRRUP REINFORCEMENT SHALL BE DETERMINED BY THE DESIGNER.
 NOTE: NO BEAM ENDS SHALL BE SKEWED LESS THAN 60° REGARDLESS OF BRIDGE SKEW.
 NOTE: FLARE STIRRUPS FOR BEAMS WITH 60° - 75° SKEWS. PLACE STIRRUPS PARALLEL TO END OF BEAM FOR 75° - 90° SKEW. BARS H300 ARE ALWAYS PARALLEL TO END OF BEAM.
 NOTE: 12" MAXIMUM SPA., 8" MINIMUM SPA. FOR PROJECTED BARS. SIZE AND SPACING OF BARS TO BE DETERMINED BY INDIVIDUAL DESIGN REQUIREMENTS. WHEN ADDITIONAL HORIZONTAL SHEAR REINFORCEMENT BEYOND THAT PROVIDED BY DOUBLE ZA- BARS @ 8" SPACING IS REQUIRED, USE SUPPLEMENTAL REINFORCEMENT PER DETAIL "A".
 (A) NOTE: THIS IS A MINIMUM DIMENSION AND MAY BE INCREASED IN INCREMENTS OF 1/2" AS REQUIRED BY DESIGN.

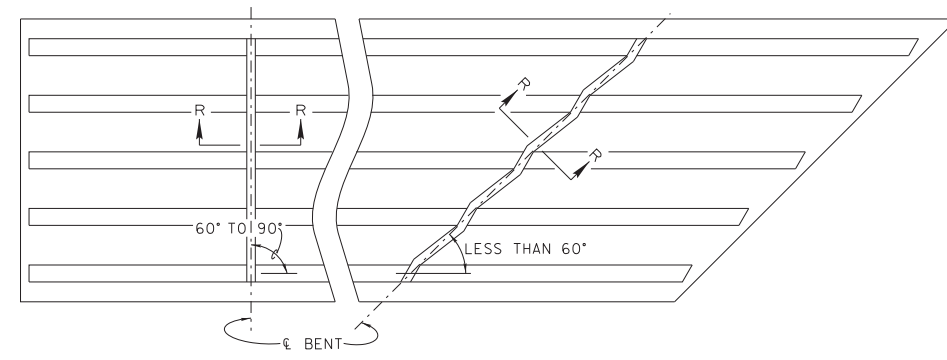

PLAN SHOWING SUPPORT DIAPHRAGMS

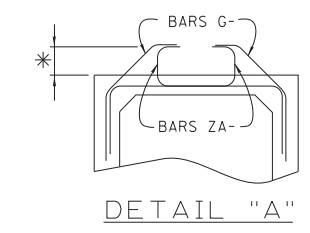

DETAIL "A"

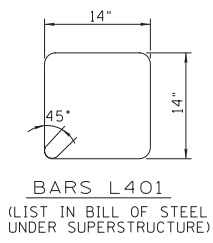

BAR L401 (LIST IN BILL OF STEEL UNDER SUPERSTRUCTURE)

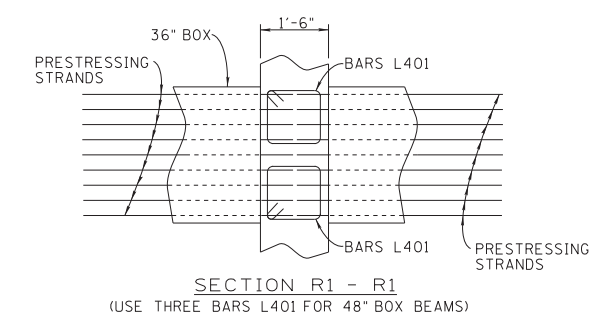

SECTION R1 - R1 (USE THREE BARS L401 FOR 48" BOX BEAMS)

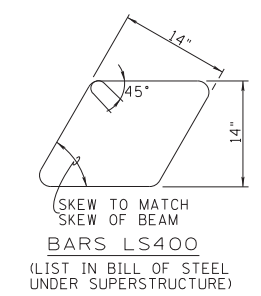

BAR LS400 (LIST IN BILL OF STEEL UNDER SUPERSTRUCTURE)

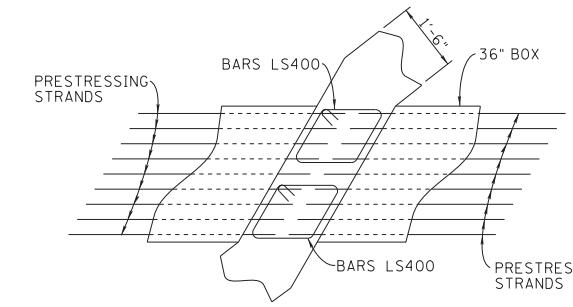

SECTION R1 - R1 (USE THREE BARS LS400 FOR 48" BOX BEAMS)

PROJECT NO.	YEAR	SHEET NO.
	2022	

REVISIONS			
NO.	DATE	BY	BRIEF DESCRIPTION
1	12-08-23	ALP	GENERAL REVISIONS

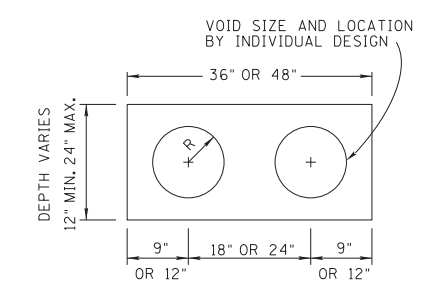
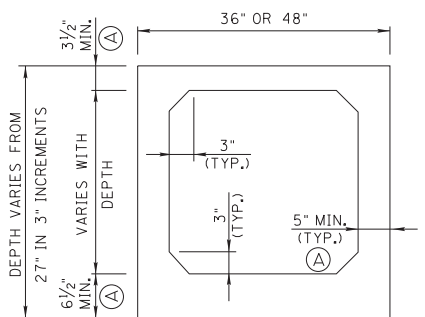

DIMENSIONS OF SECTIONS

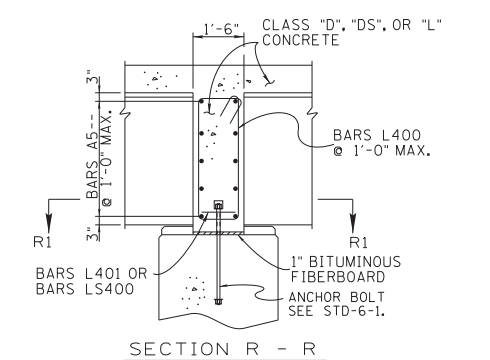

SECTION R - R

STATE OF TENNESSEE
 DEPARTMENT OF TRANSPORTATION

STANDARD DETAILS FOR PRESTRESSED BOX BEAMS 2022

CORRECT *Jed A. Krzyzewski*
 ENGINEER OF STRUCTURES

FIGURE 22. STANDARD DETAILS FOR PRESTRESSED BOX BEAMS

Version History and Revision Summary

Version history and a summary of revisions are given in Table 2. Minor editorial revisions may not be included in the summary.

Version	Revision Summary
01012022	Initial Release
12082023	Added Version History and Revision Summary; Revised notes for Figure 4, Revised 5-110.00 and 5-110.01, Added tables and figures for bulb-tee beams with 8" webs and wide bulb-tee beams.

Table 2. Version History and Revision Summary