

▲ TYPICAL DETAILS FOR GIRDER TYPE BRIDGES

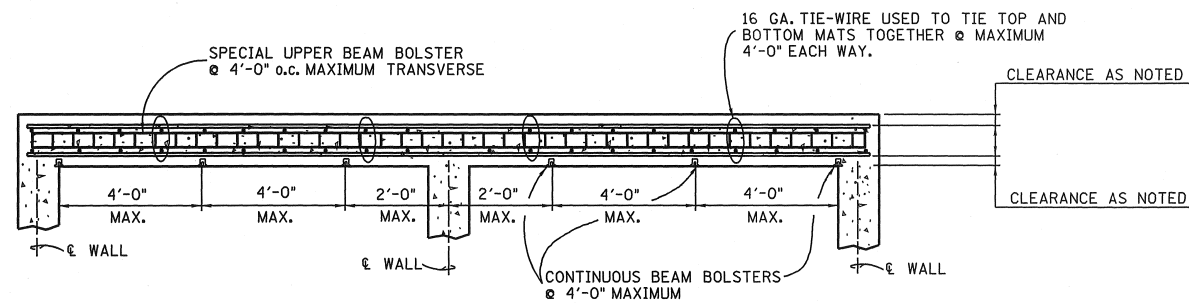

▲ TYPICAL DETAILS FOR BOX TYPE STRUCTURES

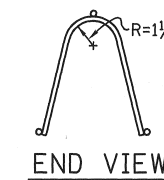
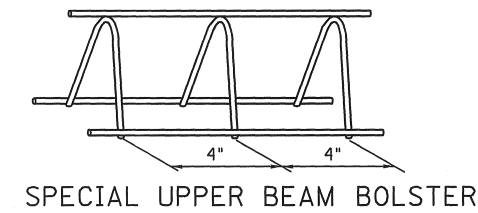
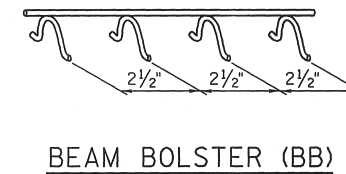
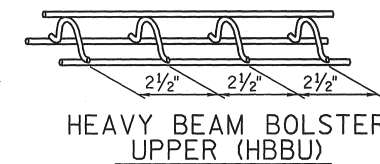

▲ TABLE A

BAR SIZE	APPROX. DIA. OUTSIDE DEFORMATIONS (INCHES)
#3	7/16"
#4	9/16"
#5	11/16"
#6	7/8"
#7	1"

▲ TABLE B

BAR SIZE	APPROX. DIA. OUTSIDE DEFORMATIONS (INCHES)
#8	1 1/8"
#9	1 1/4"
#10	1 7/16"
#11	1 5/8"
#12	1 7/8"
#13	2 1/2"

PROJECT NO.	YEAR	SHEET NO.	
REVISIONS			
NO.	DATE	BY	BRIEF DESCRIPTION
1	8-27-76		REVISED NOTE #10 @ ADDED TABLE A * B ADDED NOTE #13
2	9-1-93		CHANGED DIM. NO. FROM K-20-14
3	12-19-94	MAH	ADDED NOTE 14
4	10-7-98	JHW	REVISED DETAILS

- REINFORCEMENT IN BRIDGE SLABS AND TOP SLABS OF BOXES SHALL BE SECURELY SPACED FROM THE FORMS BY METAL SPACERS AS INDICATED THIS SHEET. OTHER TYPE SPACERS WILL NOT BE PERMITTED.
- ALL BEAM BOLSTERS (BB) AND HEAVY BEAM BOLSTER UPPER (HBBU) AND SPECIAL UPPER BEAM BOLSTER SHALL BE MADE ACCORDING TO C.R.S.I. SPECIFICATIONS.
- BEAM BOLSTER (BB) LEGS IN CONTACT WITH FORMS AND TO BE AT EXPOSED SURFACE OF CONCRETE, SHALL BE EITHER "PLASTIC PROTECTED" OR "STAINLESS STEEL PROTECTED".
- REINFORCING BARS SHALL BE SECURELY FASTENED TOGETHER AT EACH INTERSECTION USING A MINIMUM 16 GA. TIE WIRE, EXCEPT WHERE SPACING IS LESS THAN ONE FOOT IN EACH DIRECTION, ALTERNATE INTERSECTIONS SHALL BE FASTENED.
- REINFORCING BAR SUPPORTS SHALL BE FURNISHED TO MINUS 1/16" OR PLUS 1/8" OF SPECIFIED BAR.
- THE TOP AND BOTTOM REINFORCING MATS SHALL BE TIED TOGETHER AT MAXIMUM OF 4'-0" O.C. EACH WAY.
- WHEN ANY TYPE SHEAR CONNECTOR PROTRUDES FROM THE TOP FLANGE OF THE BEAM, THE REINFORCING STEEL SHALL BE TIED TO THESE CONNECTORS AT MAXIMUM 2'-0" O.C. ALONG THE BEAM.
- REINFORCING STEEL SHALL NOT BE USED TO SUPPORT CONCRETE BUGGIES, MATERIAL CARTS OR BUNDLES OF RE-BARS.
- COST OF ALL BAR SUPPORTS AND TIE WIRE SHALL BE INCLUDED IN BID PRICE FOR REINFORCING STEEL.
- A REINFORCING BAR MAY BE SUBSTITUTED WHEN HEAVY BEAM BOLSTER UPPER OF A 1" OR LESS HEIGHT IS REQUIRED. SEE TABLE A ABOVE.
- A SPECIAL UPPER BEAM BOLSTER (AS DETAILED THIS SHEET) MAY BE SUBSTITUTED FOR HEAVY BEAM BOLSTER UPPEERS REQUIRED IN HEIGHTS OF 5 1/4" OR GREATER.
- STEEL IN TOP AND BOTTOM OF SLABS OF REINFORCED CONCRETE HOLLOW BOX GIRDERS WILL BE SUPPORTED IN ACCORDANCE WITH THIS DRAWING.
- PLASTIC PROTECTED LEGS SHALL BE DIPPED AND BAKED ONTO THE UNTURNED LEGS PER THE LATEST C.R.S.I. SPECIFICATIONS.
- STAINLESS PROTECTED LEGS SHALL BE MADE FROM STAINLESS STEEL WITH A MINIMUM CHROMIUM CONTENT OF 16% (SIMILAR TO AISI TYPE 430) PER THE LATEST C.R.S.I. SPECIFICATIONS.
- USE TABLE A AND/OR B FOR BAR SIZES TO DETERMINE BEAM BOLSTER SIZE TO USE.
- REINFORCING STEEL FOR THE BOTTOM MAT OF APPROACH SLABS AND BOTTOM SLABS OF BOX BRIDGES AND CULVERTS MAY BE SUPPORTED ON PRECAST CONCRETE OR MORTAR BLOCKS, PROVIDED THE LINES AND GRADE SHOWN ON PLANS AND THE REQUIREMENTS OF SECTION 604 TENNESSEE SPECIFICATIONS ARE SATISFIED.

MINOR REVISION - FHWA APPROVAL NOT REQUIRED

STATE OF TENNESSEE
DEPARTMENT OF TRANSPORTATION
STANDARD
REINFORCING BAR
SUPPORT DETAILS FOR
CONCRETE SLABS

DESIGNED BY _____ DATE _____
DRAWN BY K.L. FRANKENFIELD DATE 9-87
SUPERVISED BY J. FIELDS DATE 9-87
CHECKED BY _____ DATE _____

CORRECT *Edward P. Wasserman*
ENGINEER OF STRUCTURES