

Table of Contents

SECTION 6.01 – INTRODUCTION..... 3

SECTION 6.02 – DOCUMENTATION PROCEDURES..... 5

SECTION 6.03 – DATA REQUIREMENTS 7

 6.03.1 WATERWAY DATA..... 7

 6.03.1.2 STREAM SLOPE 8

 6.03.1.3 HYDRAULIC ROUGHNESS 8

 6.03.1.4 TAILWATER CONDITIONS 9

 6.03.2 EXISTING SITE DATA 9

 6.03.2.1 CHANNEL ALIGNMENT AND STABILITY 10

 6.03.2.2 DEBRIS LOAD 10

 6.03.2.3 EXISTING CULVERT AND ROADWAY DATA 11

 6.03.2.4 EXISTING CULVERT PERFORMANCE 11

 6.03.3 PROPOSED SITE DATA..... 12

 6.03.4 DATA ON THE DESIGN HEADWATER ELEVATION..... 12

SECTION 6.04 – GUIDELINES AND CRITERIA 13

 6.04.1 SITE LAYOUT 13

 6.04.1.1 CULVERT LOCATION AND ALIGNMENT 13

 6.04.1.2 MULTIPLE OPENINGS..... 17

 6.04.2 CULVERT SIZE AND TYPE SELECTION..... 19

 6.04.2.1 DESIGN FLOOD FLOW RATES 20

 6.04.2.2 PIPE SELECTION CRITERIA 20

 6.04.2.3 MINIMUM PIPE COVER 21

 6.04.2.4 SELECTION OF CULVERT SIZE 21

 6.04.2.5 ALLOWABLE OUTLET VELOCITY..... 25

 6.04.3 SELECTION OF APPURTENANCES 25

 6.04.3.1 END TREATMENTS 25

 6.04.3.2 IMPROVED INLETS..... 27

 6.04.3.3 RIPRAP SCOUR PROTECTION FOR CULVERT OUTLETS..... 29

 6.04.3.4 DEBRIS CONTROL 30

 6.04.3.5 STOCK PASSES 31

SECTION 6.05 – DESIGN PROCEDURES 32

 6.05.1 ASSEMBLE DATA 32

 6.05.2 CULVERT SIZING PROCESS 32

 6.05.2.1 DETERMINE THE INLET CONTROL HEADWATER DEPTH, HW_i 32

 6.05.2.2 DETERMINE THE OUTLET CONTROL HEADWATER DEPTH, HW_o 33

 6.05.2.3 DETERMINE THE CONTROLLING HEADWATER DEPTH 39

 6.05.3 COMPUTATION OF ROADWAY OVERFLOW 40

 6.05.4 COMPUTE OUTLET DEPTH AND VELOCITY 42

 6.05.5 RIPRAP APRON DESIGN..... 42

 6.05.6 DESIGN OF “BROKEN BACK” CULVERTS FOR VELOCITY CONTROL.. 44

 6.05.7 REVIEW RESULTS..... 46

SECTION 6.06 – ACCEPTABLE SOFTWARE 47

 6.06.1 GEOPAK DRAINAGE 47

| | | |
|-------------------------------|---|-----|
| 6.06.2 | HDS-5, HYDRAULIC DESIGN OF HIGHWAY CULVERTS | 48 |
| 6.06.3 | COMPUTER PROGRAM HY-8 | 48 |
| 6.06.4 | COMPUTER PROGRAM HEC-RAS | 49 |
| SECTION 6.07 – APPENDIX | | 50 |
| 6.07.1 | FIGURES AND TABLES | 50 |
| 6.07.2 | EXAMPLE PROBLEMS..... | 72 |
| 6.07.2.1 | EXAMPLE PROBLEM #1: CIRCULAR CULVERT SOLUTION BY HAND COMPUTATIONS | 72 |
| 6.07.2.2 | EXAMPLE PROBLEM #2: CIRCULAR CULVERT USING HY-8 | 80 |
| 6.07.2.3 | EXAMPLE PROBLEM #3: CIRCULAR CULVERT WITH ROADWAY OVERTOPPING | 90 |
| 6.07.2.4 | EXAMPLE PROBLEM #4: HY- 8 IMPORVED INLET DESIGN..... | 93 |
| 6.07.3 | GLOSSARY..... | 102 |
| 6.07.4 | REFERENCES..... | 110 |
| 6.07.5 | ABBREVIATIONS | 112 |

SECTION 6.01 – INTRODUCTION

This chapter presents the procedures and methods used by the Tennessee Department of Transportation (TDOT) in the design of highway cross drains or culverts. This information is presented under the assumption that the designer is familiar with the essential hydraulic behavior of culverts and understands the open-channel and closed conduit flow theories needed to analyze their hydraulic performance.

A culvert is defined as a structure which meets all of the following criteria:

- A structure that is used to convey runoff through embankments
- A structure, as distinguished from bridges, which is usually covered with embankment and is composed of structural material around the entire perimeter, although some are supported on spread footings with the stream bed serving as the bottom of the culvert
- A structure which has less than a 20-foot span length along the centerline of the roadway. If multiple barrels are present, the span between extreme ends of the openings is considered. Figure 6-1 illustrates the definition of span length for various structural configurations. A structure which has a span of 20 feet or greater when measured as described above is considered a bridge.

When confronted with the hydraulic analysis of a given structure, the designer must consider the overall hydraulic behavior of the structure. It is possible that a structure with a span of greater than 20 feet could be hydraulically “long” and would be analyzed as a culvert using the procedures provided in this chapter. Similarly, a structure with a span of less than 20 feet may behave more as a bridge, if its length is approximately equal to its span.

This chapter does not discuss hydrologic methods for determining flood discharges to be used in culvert design. Details on these methods are provided in Chapter 4 of this Manual. Where it is determined that the 50-year flood discharge at a site is greater than 500 cfs, all of the data assembled to support the culvert design will be transferred to the TDOT Hydraulic Section. The Hydraulic Section will then provide the analysis necessary to determine the size and type of the proposed structure.

The criteria provided in this chapter will apply to pipe culverts or four-sided precast boxes. Although three-sided slab-top structures and arch-box structures frequently behave hydraulically as culverts, they are most commonly applied in situations where the 50-year discharge is greater than 500 cfs. Thus, the design of such structures is not discussed in this chapter.

The general culvert design process consists of three phases. The first is that of data collection, which consists of gathering the data needed to complete the design of the culvert. The second is selection of the structure size, type and end treatments. The first two phases are typically accomplished during the development of the Preliminary Plans. Typically, the proposed culvert design would be coordinated with the Environmental Planning Division during the first two phases. The third phase is the documentation of the design process. This chapter will provide the designer with the guidance necessary to carry out each of the phases of this design process.

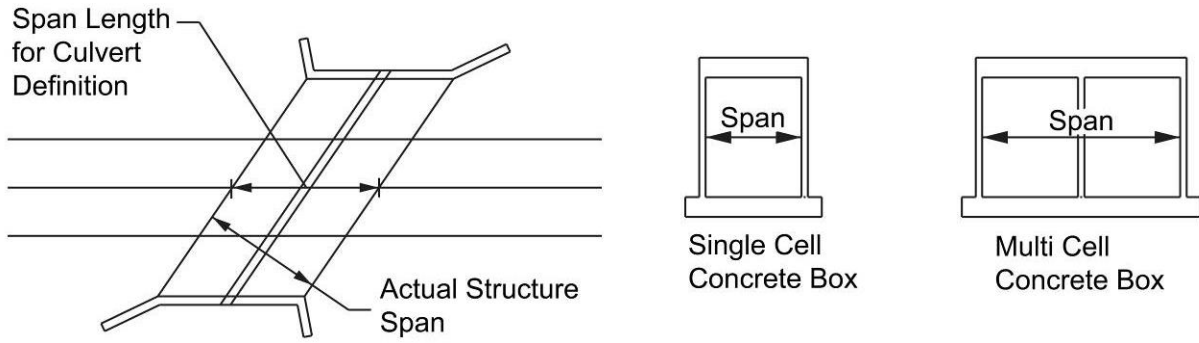

Figure 6-1
Culvert Span Length

SECTION 6.02 – DOCUMENTATION PROCEDURES

The designer will be responsible to document the computations and design decisions made for the design of each culvert within the roadway project. In general, the documentation should be sufficient to answer any reasonable question that may be raised in the future regarding the proposed culvert design. The documentation for each culvert should be grouped together and be organized by roadway station from the beginning of the improvement to the end.

The documentation should include the general information necessary to identify and describe the proposed culvert design. This should include:

- roadway station
- whether the culvert will be a cross drain or side drain
- storm design frequency, flow rate and the source of this information
- fill height

Existing site data collected to support the design of the proposed culvert data should also be included in the documentation. This should include:

- photographs of the site, if they are readily available (not provided with survey)
- barrel size, barrel material, condition, length and invert elevations of the existing culvert, if any
- elevation data on any structures or other features upstream of the culvert that could be affected by flooding
- data on high water marks at the site, if any exist
- a qualitative discussion of the type and quantity of debris that may be expected at the site

The elevation of the tailwater surface at the site may be determined in a number of different ways. The documentation should include a clear indication of the means used to determine this elevation. If the elevation is based upon hydraulic analysis of the downstream valley, the documentation should include a plot of the valley cross section. In addition, a discussion should be included of how the Manning’s n-values and tailwater slope were determined. If the tailwater surface elevation is based upon a “known” water surface elevation or some type of downstream control, the documentation must clearly indicate the source of this information.

The documentation of the proposed design should include a topographic map showing the alignment of the proposed culvert. The scale of this map should be sufficient to show the alignment of the proposed roadway, elevations in the stream channel served by the culvert and the proposed limits of construction. The extent of the map should be large enough to include any channel changes that may be required to accommodate the proposed culvert alignment. Normally, this map will be based upon the survey for the roadway improvement.

The documentation should include the size, length and invert elevations of the final proposed culvert selected for the site. Often, the process of selecting a final culvert size involves trial and error with a number of different sizes and it will not be necessary to include information on other culvert sizes which were rejected. The documentation should include information on the design headwater elevation used to size the proposed culvert. A list of any alternate culvert materials that may be allowed is generally provided in the plans. Occasionally, the designer will

require the use of a specific culvert material even where alternate materials would be acceptable. The documentation should include some discussion as to why it was necessary to limit the choice of material.

In situations where an improved inlet might be an option, the documentation should include:

- all of the design computations for the improved inlet
- any cost analysis performed to justify the use of an improved inlet
- an evaluation of the debris present at the site

When necessary, the documentation may also include a discussion of the types of end treatment selected for the proposed culvert. This could include:

- a record of any decision to lengthen the culvert so that the ends would be outside of the clear zone
- a discussion of why a particular end treatment was selected at the site
- any computations made to assess head loss at the end treatments

The outlet velocity for the selected culvert at the design flow should be documented along with the design of the erosion protection downstream of the culvert. Where a riprap apron is used as erosion protection, the documentation should include the computations used to determine the apron dimensions. In situations where an energy dissipator is required, the documentation should be as discussed in Chapter 9 of this Manual.

All of the hand computations connected with the final culvert design should be included in the documentation. Each computation sheet should be provided with a header that includes the project description, a description of the type of computation, the project station, the date, and the initials of the designer. These computations shall be neat and legible. Computations for trial culvert sizes other than the final design should not be included in the documentation. Any record of these computations should be maintained by the designer. In no case should design documentation be destroyed or removed from the project file prior to completion of the project.

When computerized computations are employed, the data files should be clearly labeled with the project description, project station, purpose of the computation (i.e., existing or proposed analysis), date and initials of the designer. Any important assumptions made in developing the input data should also be documented. When possible, this information should be included with the data input to the program. Otherwise, it will be necessary to label output files. Hard copies of output reports sufficient to document the hydraulic performance of the proposed culvert should be included in the documentation, along with a floppy disk containing all of the relevant data files.

The documentation should also include a discussion of any unusual features or conditions within the project. This discussion should include all of the assumptions and design decisions made by the designer to accommodate these special conditions.

SECTION 6.03 – DATA REQUIREMENTS

To properly locate and design a proposed culvert installation, the designer should begin by assembling the data needed to support the design. This can include hydrology, waterway data, roadway data, design headwater data, and data on features affected by installation of the culvert. In general, this information should be kept in the culvert design file as discussed in Chapter 6.

This section describes in detail a comprehensive list of the various data that should be assembled and recorded. However, each culvert site presents a unique set of circumstances and the designer should use engineering judgment in determining the relative importance of each of the items discussed below. Unique site conditions may require that additional types of information be collected; or may make other types of information irrelevant. Once the required data has been assembled, hydraulic analysis and design may begin, as discussed in Sections 6.04 and 6.05.

Although much of the needed data will be readily available from the project survey, a number of sources may be available for gathering other needed data. These include Advance Planning Report, Final Scoping Report, site inspection, topographical maps, photographs of the stream, and aerial photography of the site as a whole. Each of the sections below provides some additional detail regarding possible sources for the data item it covers.

The data required for the design of a culvert may be classified into four broad categories: waterway data, existing site data, proposed site data and data to support the selection of the design headwater elevation.

6.03.1 WATERWAY DATA

The installation of a culvert to convey surface water through a highway embankment frequently places a constriction on the floodplain. To predict the consequences of this alteration, accurate preconstruction waterway data should be collected. This data includes cross sectional information, stream slope, the hydraulic roughness of the stream channel and floodplain, and any condition affecting the downstream water surface elevation.

6.03.1.1 STREAM CROSS SECTIONS

Stream cross sectional data is important to the hydraulic analysis of a culvert. Usually, cross sectional information on the stream carried by the culvert can be obtained from the digital terrain model provided in the project survey. This information may be used to determine much of the data required for the culvert cross section (see Section 6.04.1.1.1.1), including the stream slope and the culvert inlet and outlet elevations. This information should also be used to determine the hydraulic capacity of the stream.

It is important that the cross sections used in the hydraulic analysis of the culvert be representative of the overall shape of the stream channel and overbanks. Sound engineering judgment should be used when obtaining stream cross sections from the survey. If the proposed culvert will be part of a new road, it may be helpful to locate the cross sections at about the points where the proposed roadway embankment toes will intersect the stream. If the proposed culvert will be a replacement of an existing structure, the cross sections should be taken as close as is practical to the existing culvert inlet and outlet. However, care must be exercised to insure that the cross sections are located beyond any existing channel transitions or beyond the extent of any local scour effects (“blow holes,” etc.) that are due to flows into and out of the existing culvert.

It is also important that stream cross sections be sufficiently wide to represent the entire floodplain. That is, the cross-sectional data used to analyze a culvert must include the entire channel cross section and any areas on the overbanks which may convey water in the design flood. When all of the needed information is not included in the project survey, it may be possible to use other existing topographic mapping to construct a complete valley cross section. Where the stream is at a skew with respect to the proposed roadway, it may be possible for a cross section that is perpendicular to flow to extend past the edge of the digital terrain model. In such situations, cross sectional data may be obtained along a line parallel to the roadway and the cosine of the skew angle may be applied to correct the cross section width.

If significant ponding is likely upstream of the culvert, additional stream cross sections may be necessary to evaluate upstream water surface elevations. Likewise, if it appears that conditions downstream of the proposed culvert may create a high tailwater condition, additional sections may be necessary to evaluate downstream flow elevations.

Where only one cross section of the stream is available, it may be possible to apply it as a typical cross section. This assumption should be checked using any available topographic maps, and sound engineering judgment. If feasible, this cross section should be located as near as possible to any structures that may be subject to flooding during extreme events.

6.03.1.2 STREAM SLOPE

The longitudinal slope of the existing channel, in the vicinity of the proposed culvert, should be defined to properly position the culvert in the channel bottom profile, and to analyze the flow characteristics of the natural stream. Often, the proposed culvert is positioned at the same longitudinal slope as the streambed. Cross sections will provide streambed elevations at the deepest point of the stream. Using these elevations with the distance between the cross sections, it is possible to calculate the stream slope.

The stream slope determined from the surveyed cross sections should be carefully evaluated before it is applied in the hydraulic analysis of the stream and proposed culvert. This slope should be examined for consistency with the overall valley slope as determined from topographic mapping for the stream. If the local slope determined from the cross sections is significantly different than the slope determined from the mapping, the generalized slope from the mapping may yield a more accurate hydraulic analysis.

It should always be kept in mind that the energy slope of the flow may not always be equal to the slope of the channel. Occasionally, the designer will need to carefully evaluate downstream conditions as described in Section 6.03.1.4, before assuming that the energy slope will be equal to the channel slope. However, in most design situations, this assumption will generally be considered adequate.

6.03.1.3 HYDRAULIC ROUGHNESS

The hydraulic resistance of the natural channel must be evaluated to determine natural flow elevations for the stream. All of the software packages approved for the hydraulic analysis of culverts use Manning's n-value to quantify this resistance. Where available, photographs of the stream may provide the information needed for the selection of n-values at a site. Specific

guidance on selecting Manning's n-values for channels and floodplains can be found in Section 5.03.3 of this Manual.

6.03.1.4 TAILWATER CONDITIONS

Usually, the tailwater elevations experienced at a culvert outlet will be determined by the hydraulic conveyance and downstream slope of the stream. However, tailwater elevations can often be significantly increased by downstream conditions including impoundments, obstructions, channel constrictions, and junctions with other watercourses. Therefore, conditions which might promote high tailwater elevations during flood events should be investigated and carefully evaluated before any hydraulic analysis of the stream or proposed culvert is conducted. The presence of such conditions can most often be determined from field observations and topographic maps.

Proper care should be exercised in evaluating whether a high tailwater condition should be considered in the hydraulic sizing of a proposed culvert. A culvert size selected on the basis of a high tailwater condition will often be significantly smaller than a size selected based strictly upon the hydraulic conveyance of the downstream channel. Thus, a design that is adequate for a high tailwater condition may become inadequate should the downstream obstruction be removed. One example of this situation would be a restrictive culvert located a short distance downstream from the highway project site. A proposed culvert design based upon the backwater created by restrictive culvert would yield a proposed highway culvert size similar to that of the restrictive culvert. Should the agency owning the restrictive culvert chose to replace it with an adequately sized structure, the upstream highway culvert would become the new restriction point. On the other hand, had the highway culvert design been based only upon the hydraulic condition of the natural channel, no restriction would remain.

When a high tailwater condition results from the existence of a stream junction near the project site, the designer should carefully evaluate whether flood elevations on the receiving water body should be considered. In general, if flood discharges on the two streams are likely to peak at about the same time, it would be acceptable to consider the higher tailwater in the culvert design. However, if the peak flow times are likely to be significantly different, the culvert design should be based upon the hydraulic capacity of the channel.

When a culvert has been sized based upon the downstream conveyance of the channel, its performance under high tailwater conditions should be checked. Even though the culvert size has been determined based upon a low tailwater elevation, other aspects of the culvert design may be affected by the high tailwater condition.

In the absence of a high tailwater condition, the proposed culvert sizing should be based on water surface elevations in the natural channel. Where sufficient data exists, these elevations can be accurately determined from water surface elevation profile computations. However, the tailwater elevation will most often be estimated as the normal depth in the downstream cross section.

6.03.2 EXISTING SITE DATA

When a project includes the replacement of an existing culvert, a careful inspection and evaluation of the existing site conditions will yield important insights into the design of the proposed structure. The size, invert elevations and condition of the existing culvert should be

noted along with the grade of the roadway and any evidence indicating the performance of the existing culvert such as high water marks or debris along the upstream channel banks, or information from local land owners.

Existing site data is important even when the project comprises a new road alignment. The existing channel alignment and the presence of wetland areas at a project site will have a significant impact on the proposed culvert design. The hydraulic performance of any existing culvert at the site should be evaluated, as described in Section 6.03.2.4.

6.03.2.1 CHANNEL ALIGNMENT AND STABILITY

Ideally, a proposed culvert should be located on the existing channel bed to minimize costs associated with structural excavation and channel work. Where the channel is relatively straight, this is not an issue; however, where streambeds are sinuous, this is not always possible. In such situations, a portion of the stream channel may have to be relocated to accommodate the culvert construction project. In these situations, aerial photographs and USGS quadrangle maps will be of value in determining the location of the proposed structure. In general, these should be available as a part of the survey data for the project. Section 5.05 of this Manual provides criteria for stream relocation design.

Initial screening for the potential impact of a project to downstream systems should be conducted in the early planning phases of a project. An evaluation report should be developed for each project stormwater outfall which meets the following criteria:

- the outfall is located within a project which affects an area of one or more acres;
- the drainage area at the outfall is one acre or more;
- 10% or more of the area draining to the outfall in the post-project condition is impervious surface; and
- the outfall discharges directly into a stream or other natural water resource.

In addition to the criteria given in Section 8.04.2.1 for an evaluation report it is important to evaluate the stability of the stream and consider the effect of the proposed project on stream morphology. Features to be examined include the occurrence or possibility of streambed degradation (head cutting) which may be caused by downstream dredging or channel modifications such as straightening. Signs of bank slippage and erosion should be noted, as well as buildings or other structures that appear to be located too close to the bank. The presence of trees growing at odd angles from the bank, exposed tree roots, and trees that have fallen into the stream should also be noted. The composition of channel bed materials should be considered as well as the location and likely direction of any lateral migration. These factors should be carefully considered to insure that the concentration of flow velocity created by the proposed culvert will not result in unintended consequences to the morphology of the stream. When available, photographs of the channel upstream and downstream of the project, as well of the adjoining floodplain, can be valuable aids for the documentation of existing conditions.

6.03.2.2 DEBRIS LOAD

Flood flow reaching a culvert nearly always carries debris which may be either floating material, material heavier than water, or a combination of both. Debris is a concern because it can be deposited at the culvert entrance or become lodged in the culvert, thus impairing its

operation. Although debris accumulation is generally considered to be a maintenance issue, the designer should give this issue due consideration at sites where heavy debris loads may be present. A number of the design guidelines and criteria provided in Section 6.04 are intended to deal with the issue of debris accumulation in a cost-effective manner.

6.03.2.3 EXISTING CULVERT AND ROADWAY DATA

Where an existing culvert is to be replaced, hydraulic analysis of the existing structure serves as a base line for the proposed hydraulic design and often provides insight to special conditions at the site. The designer must therefore gather information on the existing culvert including its length, invert elevations, barrel size, material and end treatments. The condition of the existing structure should also be noted.

The roadway embankment represents an obstruction to the flowing stream in a manner similar to a dam. When the headwater attains sufficient elevation, the roadway embankment will begin to function as a spillway. Thus, information should also be collected on the existing roadway profile at the culvert site. The designer should carefully note the location at which overtopping will begin to occur and compare roadway elevations to the tailwater surface elevation. In situations where the alignment of the stream is perpendicular to the roadway, the roadway overflow section will be identical to the roadway profile. However, in situations where the stream is skewed with respect to the road, it is necessary to carefully consider the effective length of the roadway overflow. When the tailwater elevation is sufficiently high to submerge flows across the road, the roadway cross section will behave in a manner similar to a valley cross section and the roadway cross section data should be taken normal to flow instead of parallel to the roadway alignment. In contrast, when the tailwater is sufficiently below the roadway elevation, the roadway cross section will form a weir, and data should be taken along the alignment of the roadway.

In many cases, the culvert is located beneath a fill sufficiently high that the roadway would not be overtopped in any flood event. In these cases, only a minimal amount of effort should be expended on obtaining roadway data.

Roadway profile information and details on the existing culvert can be obtained from preliminary roadway drawings, from the site survey and from field visits.

6.03.2.4 EXISTING CULVERT PERFORMANCE

In many situations, evaluating the hydraulic performance of an existing culvert will provide information useful for the design of the proposed structure. In particular, scour holes, erosion around the upstream or downstream abutments, or abrupt changes in bed material gradation may all indicate that the existing structure is too small for the site. When possible, the designer should note whether there is any evidence of significant scour at the existing culvert site, and where practical, its size and depth should be determined.

When a site visit is conducted shortly after a high water event, it may be possible to estimate the depth of flooding upstream of the culvert and to determine the extent of any possible flood damages.

6.03.3 PROPOSED SITE DATA

To begin the design of a proposed structure, it will be necessary to obtain information on the proposed roadway profile and typical roadway cross section. Thus, it will be necessary to establish the proposed profile grade before the design of the proposed culvert may begin. The information needed can usually be obtained from the digital terrain model for the preliminary roadway plans. Typically, the roadway cross section taken from the preliminary plans will be normal to the centerline. However, where the culvert is skewed with reference to the roadway centerline, it may be necessary to combine roadway plan, profile, and typical cross-section data to produce a section along the proposed culvert alignment. Necessary dimensions and the inlet and outlet invert elevations of the proposed culvert may be determined by superimposing the estimated culvert profile on the roadway cross section and the streambed profile.

6.03.4 DATA ON THE DESIGN HEADWATER ELEVATION

Prior to designing the proposed structure, it is necessary to determine the locations and elevations of any insurable structures, driveways, utilities and any other facilities near the project site that may be affected by culvert headwater for all flood events up through and including the 100-year storm. An effort should be made to address any local concerns that may result from the ponding of water.

SECTION 6.04 – GUIDELINES AND CRITERIA

Design criteria form the basis for the final design configuration. This section presents design standards and guidance for determining a site layout, selecting culvert size and type, and selecting appropriate culvert appurtenances.

6.04.1 SITE LAYOUT

The first step in designing a proposed culvert is to situate the structure on the project site. The project length, horizontal alignment and vertical alignment must be established to provide a design that minimizes impacts on the natural stream system, addresses environmental concerns, provides compatibility with the proposed highway design and minimizes cost.

6.04.1.1 CULVERT LOCATION AND ALIGNMENT

Culvert location involves the horizontal and vertical alignment of the culvert with respect to both the stream and the highway. The culvert location affects hydraulic performance of the culvert, stream and embankment stability, construction and maintenance costs, safety and integrity of the highway and the environmental impact of the project.

6.04.1.1.1 VERTICAL ALIGNMENT

To the extent possible, the vertical alignment of a proposed culvert should be established by placing the upstream and downstream inverts of the culvert at the existing streambed elevations. Usually, a straight culvert alignment will be established between these points to avoid clogging, minimize construction costs, and improve hydraulic efficiency. However, non-linear alignments or other exceptions to the criteria may be necessary due to site-specific conditions, subject to the approval of the Design Manager.

6.04.1.1.1.1 CULVERT CROSS SECTION

A culvert cross section is required for all cross drains and should be provided for side drains 36" and larger. These cross sections should be included within the roadway cross section sheets of the plans and show the size and type of pipe, the pipe invert elevations and the roadway embankment above the pipe. In situations where a non-linear alignment is proposed, the cross section should note the invert elevation at any break in culvert grade as well as the offset from the roadway center line where the break is to be located. Any other structures such as drop manholes or internal roughness elements should also be depicted on the cross section.

When a cross drain is skewed with respect to the roadway, the cross section should follow the alignment of the pipe.

6.04.1.1.1.2 MINIMUM CULVERT GRADES

In general, a new culvert should be provided with a slope of at least 0.5%. Flatter slopes may be allowed where project conditions make this slope infeasible. When it is necessary to specify a slope of less than 0.5%, the designer should insure that the minimum allowable flow velocity is maintained as specified in Section 6.04.2.5. However, the 0.5 percent slope criteria should not be applied to equalizer pipes used to balance the elevation of water ponded on both

sides of a roadway. Although they may be constructed at a flat grade, equalizer pipes should be at least 24 inches in diameter to facilitate maintenance.

6.04.1.1.1.3 PROVIDING NATURAL INVERT MATERIALS

In some situations, the inverts of a culvert may be placed 1 foot below the stream bed and then filled with natural substrate materials to match the stream elevations. The purpose of lining the culvert bottom in this manner is to reduce environmental impacts which may be caused by installing the culvert. Normally, this measure would be taken only in coordination with the Environmental Planning Division. Further, this measure should not be considered for streams where bedrock is encountered.

Where a proposed culvert is lowered in this manner, its hydraulic capacity will be reduced due to both the loss of flow area and the increased roughness of the bottom materials. Thus, the designer should ensure that a lowered culvert will still provide adequate hydraulic capacity, and provide a larger culvert size if it is needed.

6.04.1.1.1.4 NON-LINEAR “BROKEN BACK” ALIGNMENTS

It is often necessary to extend an existing culvert to accommodate a roadway widening project. To match existing stream grades, it is sometimes necessary to place the extended portions of the culvert at a slope which is different from the flowline slope of the existing structure, resulting in a “broken back” culvert alignment as depicted in Figure 6-2. Although this will generally be considered acceptable, consideration should be given to replacing the existing culvert, particularly if it does not appear to have sufficient hydraulic capacity. Widening a roadway may also involve increased fill heights above an existing cross drain. Thus, the designer should ensure that the existing culvert has sufficient structural capacity to withstand the added dead load, especially where the existing culvert is a concrete box.

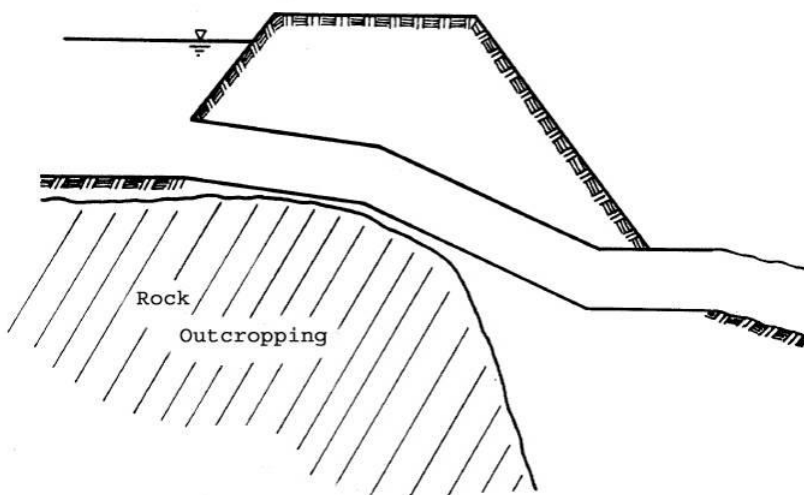

Figure 6-2
Broken Back Culvert
Reference: USDOT, FHWA, HDS-5, (1985)

Subject to the approval of the Design Manager, a “broken back” alignment may also be used for new construction to avoid costly rock excavation, avoid conflicts with existing utilities which may be difficult to relocate, or to arrest stream degradation.

Due to joint integrity concerns, high-density polyethylene pipe (HDPE) should not be used for “broken back” alignments. This includes both new culvert construction and existing culvert extensions. In general, existing HDPE pipe culverts should not be extended, nor should HDPE pipe be used to extend culverts of different materials.

Improved inlets such as the slope-tapered inlet and the side-tapered inlet also represent a non-linear vertical alignment. However, these structures are usually used to improve the hydraulic performance of a culvert. Thus, approval is not required for the use of this type of structure. Specific design guidance for improved inlets can be found in Section 6.04.3.2.

6.04.1.1.1.5 NON-LINEAR ALIGNMENTS FOR VELOCITY CONTROL

In some situations where a culvert is to be installed on a steep slope, it may be possible to control the outlet velocity by providing a non-linear alignment. Essentially, velocity reduction is achieved by reducing the slope of the downstream portion of the culvert by means of either a drop structure or a “broken back” alignment. It may be possible to specify this type of alignment in lieu of providing an energy dissipator, particularly at sites where the tailwater depth is comparatively high. The choice between specifying a non-linear alignment or providing an energy dissipator should be made primarily based upon cost; however, other issues, such as constructability and the availability of right-of-way should be considered. Detailed criteria for the design of energy dissipators are provided in Chapter 9 of this Manual.

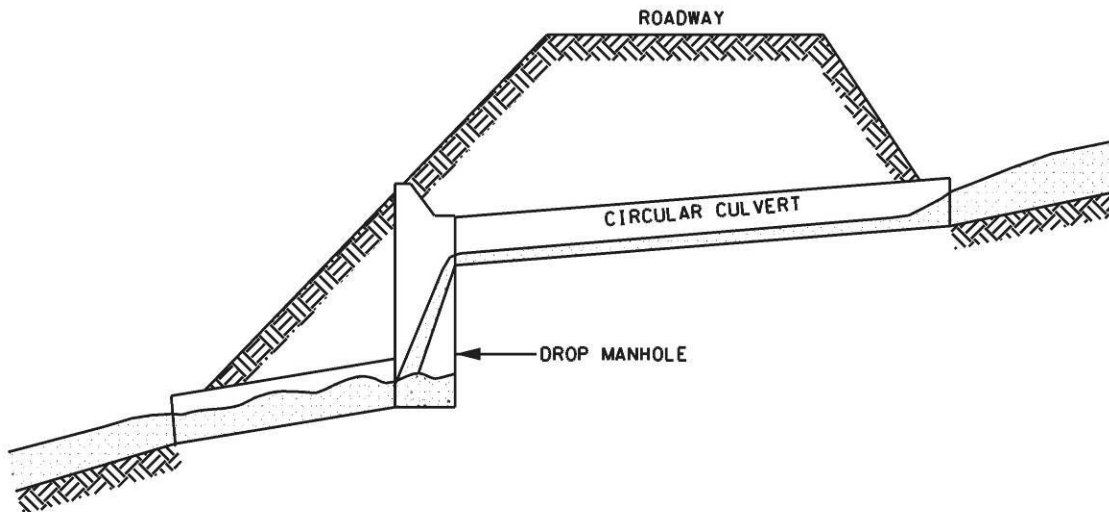

Figure 6-3
Drop Structure for Velocity Control

The use of a drop structure to control culvert outlet velocity is illustrated in Figure 6-3. The culvert consists of two segments, both at a mild slope. This configuration would most likely be used with round pipes; although, box culverts small enough to be connected to a manhole may also be considered. It is recommended that the floor of the drop manhole be provided with extra concrete to ensure that the reinforcing steel will not be exposed by the erosive action of water dropping from the upper pipe. The hydraulics of each segment of the culvert should be analyzed separately. The analysis of the downstream portion of the structure would be used to determine the culvert outlet velocity and whether headwater from the downstream portion would affect the hydraulics of the upstream structure. The analysis of the upstream structure would be used to check the allowable headwater elevation for the structure as a whole.

As shown in Figure 6-4, the “broken-back” option for velocity control consists of placing the upstream third of the culvert at a much steeper slope so that the lower two-thirds of the structure may be constructed to the minimum grade specified in Section 6.04.1.1.1.2. This method achieves velocity control by forcing a hydraulic jump in the lower portion of the structure. Generally, this method would be used only for box culverts. Further, such structures should not be specified without careful consideration of their performance. Flows in the upper third of the structure can be highly supercritical and may have sufficient momentum to carry the flow in the supercritical flow regime through the structure outfall. In this situation, the structure would not achieve its desired level of velocity control.

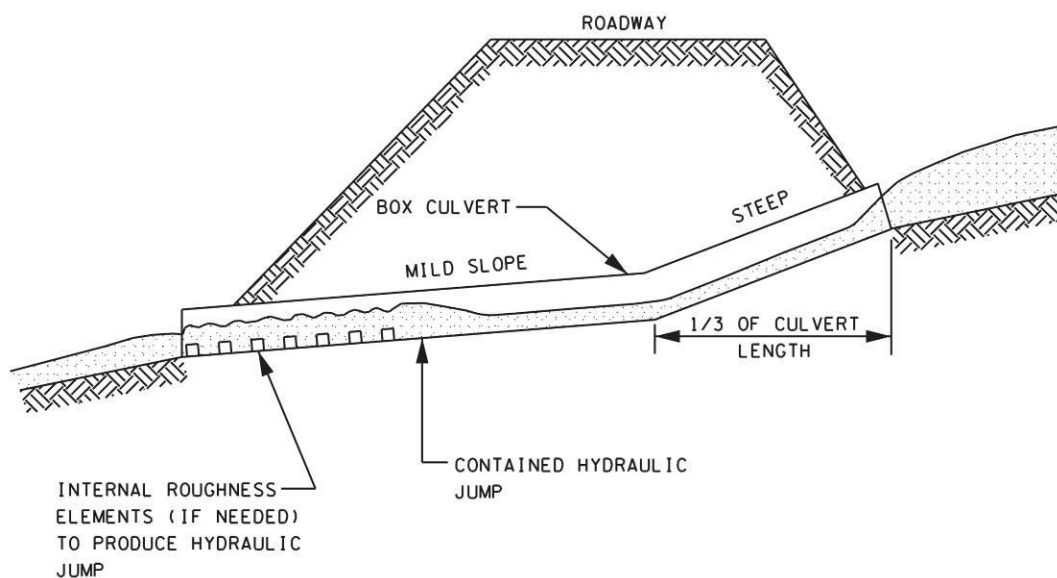

Figure 6-4
Broken-Back Culvert for Velocity Control

The hydraulic analysis of “broken-back” structures can be very complicated. If detailed hydraulic analysis should become necessary, it should be performed by means of computer program capable of computing mixed profiles (i.e. sub-critical and supercritical). A somewhat simplified hydraulic analysis method is presented in Section 6.05.6. This simplified method may

be used to determine the culvert headwater elevation and outlet velocity as well as whether or not the supercritical flow state will continue into the lower portion of the structure.

6.04.1.1.2 HORIZONTAL ALIGNMENT

To the extent possible, a proposed culvert should be located on the existing channel bed to minimize costs associated with structural excavation and channel work. As much as possible, the culvert outlet should be aligned with the downstream channel to help minimize the amount of erosion that may occur. In many situations, this will require that the proposed culvert be skewed with respect to the roadway centerline. Small culverts with no defined channel should be placed normal to the roadway centerline.

In situations where streambeds are sinuous, it may be necessary to relocate the stream channel to minimize the culvert length and to mitigate any potential for increased channel erosion caused by the project. Guidance for the design of channel changes to accommodate a culvert project is contained in Section 5.05.

The selection of horizontal alignment will also be subject to the following procedures and policies in order to achieve an environmentally acceptable project as determined by the U.S. Army Corps of Engineers, U. S. Environmental Protection Agency, U.S. Fish and Wildlife Service, Tennessee Wildlife Resources Agency, and Tennessee Department of Environment and Conservation:

- Any project which proposes long runs of boxes, channel changes on blue-line streams, and/or wetland impacts should be studied for alternate solutions. A project coordination meeting may then be appropriate between the involved TDOT Divisions to discuss the design alternates.
- Where box and slab-type culverts and bridges are employed, their length should be held to the practical minimum. In the case of interchanges, intermittent boxes, rather than continuous long boxes, are preferred.
- Given the choice between long runs of boxes and channel changes, channel changes are generally preferred.

In general, a straight horizontal alignment will be preferred at all sites to avoid maintenance problems, minimize construction costs, and improve hydraulic efficiency. However, moderate horizontal bends may be used to avoid rock outcroppings or for other purposes. When considering a nonlinear culvert alignment, particular attention should be given to erosion, sedimentation, and debris control. Further, the energy losses due to the bends must be considered in the hydraulic analysis of the culvert. Specific guidance for the analysis of culvert bends may be found in the FHWA publication HDS-5.

6.04.1.2 MULTIPLE OPENINGS

Multiple opening designs usually consist of two or more pipe or box culverts arranged horizontally across a wide stream channel. Separation distances between multiple pipe culverts should be as shown in Tables 6-1 and 6-2, while box culverts are typically placed immediately adjacent to one another. The use of multiple culvert barrels may provide hydraulic advantages in wide channels where the concentration of flow must be kept to a minimum or where low roadway embankments offering limited cover require a series of small openings. However, multiple culverts tend to catch debris which will result in blockage of the waterway. In addition, one or more of the

openings will frequently become blocked due to siltation. Thus, the cost of maintaining a multiple opening site over the life of the installation is often significantly greater than the additional construction cost necessary to place a single opening at the site.

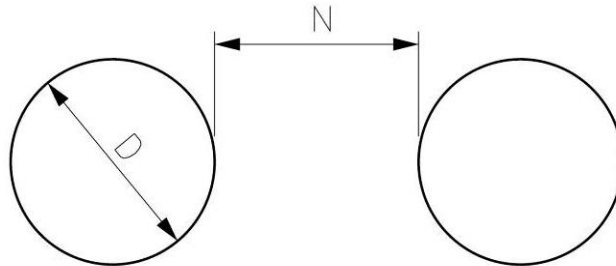

Figure 6-5
Multiple Pipe Culverts

| Pipe Diameter (inches) | Separation (N) (inches) |
|------------------------|-------------------------|
| 15 to 24 | 12 |
| 30 to 96 | 1/2 of pipe diameter |
| 102 to 120 | 48 |

Table 6-1
Minimum Separation Spacing (N) Between Pipes with Class “B” or “C” Bedding
(Not valid when Class “A” bedding is used)

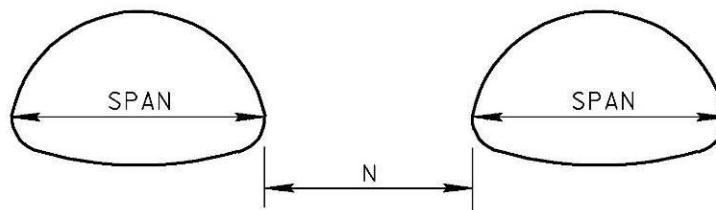

Figure 6-6
Multiple Pipe-Arch Culverts

| Pipe-Arch Span (inches) | Separation (N) (inches) |
|----------------------------|----------------------------|
| Up to 35 | 12 |
| 42 to 142 | 1/3 of pipe-arch span |
| 145 to 199 | 48 |

Table 6-2
Minimum Separation Spacing (N) Between Pipe-Arches with Class “B” or “C” Bedding
(Not valid when Class “A” bedding is used)

In general, multiple openings should not be used:

- In any non-urban setting or where a high debris potential exists
- When the approach flow has a high velocity, particularly if supercritical (such sites will suffer adverse effects from hydraulic jumps)
- In any situation with a curved stream alignment
- Where the selected culvert material is high-density polyethylene pipe

Multiple openings may be allowed:

- In urban settings where debris will be limited
- Where no single-opening configuration is feasible

Where a multiple opening design utilizes box culverts, the boxes will have uniform opening sizes and the alignment of the culvert face will be parallel to the roadway.

6.04.2 CULVERT SIZE AND TYPE SELECTION

In general, the selection of size for a proposed culvert involves specifying the most economical structure that will be adequate to convey the required design flow. Once the layout of the proposed structure has been established on the site, the culvert selection process consists of evaluating the hydraulic performance of different size and type options until an optimum design is achieved.

The basic types of culverts that are available to the designer are:

- Round pipes constructed from corrugated metal, reinforced concrete, polyvinyl chloride (PVC) or high-density polyethylene (HDPE), as determined from Table 6A-1
- Pipe arches constructed from either corrugated metal or reinforced concrete
- Horizontal elliptical reinforced concrete pipe
- Round or arched pipes constructed of structural plate corrugated metal
- Cast-in-place or precast reinforced concrete boxes

6.04.2.1 DESIGN FLOOD FLOW RATES

The specific criteria regarding flow frequencies to be used in the design of culverts are presented in Section 4.03 of this Manual. The balance of Chapter 4 presents the hydrologic methods to be used in determining flow rates for the evaluation of a given culvert option.

Occasionally, the designer will be presented with a site which includes a culvert sufficiently small to cause water to pond upstream. Even though this storage of floodwaters upstream of the culvert may allow for some reduction in the design discharge, this storage area should not be considered unless the entire area is contained within TDOT right-of-way. The available storage volume upstream of the culvert may be reduced if the roadway is widened or areas adjacent to the stream are developed. Thus, the designer generally should select culvert sizes based upon the full design flow rate at the project site.

6.04.2.2 PIPE SELECTION CRITERIA

The designer shall use Table 6A-1 when selecting pipe materials for hydraulic design purposes. The Materials Selection Table is based on the route functional classification and fill height above the pipe. Fill height is defined as the material from the top of the pipe to the riding surface, including pavement structure. The ADT used in the table should be the design year projected traffic.

When alternate pipe materials are allowed, as indicated by Table 6A-1, the designer should include all allowable alternates in the pipe tabulation. The designer should show the class and gage of concrete and corrugated metal pipe, respectively, in the pipe tabulation. Examples of the tabulation formats to be utilized for various roadway classifications are shown in Tables 6A-2 to 6A-5. The designer may alter these tables as needed to accommodate other pipe sizes or fill height situations. When necessary to accommodate the proposed design, the designer may specify that only one type of material may be used. Payment will be made under the 607-series item numbers for pipe culverts and pipe culverts (side drains).

6.04.2.2.1 USE OF PIPE CULVERTS OTHER THAN ROUND PIPE

In general, circular pipe is the preferred pipe shape; however, pipe-arches or elliptical shaped pipes may be used under circumstances where they would be necessary, such as:

- shallow-fill situations where the vertical distance between subgrade and pipe-flow line prohibits the use of circular pipe
- sites where environmental permit concerns can be reduced by the use of a wider pipe
- situations where a wider pipe can reduce the outlet velocity to help control erosion
- situations where underground utility conflicts can be avoided by using low profile structures

Metal pipe-arches may not be used on freeway, arterial, or collector systems; these are to be used on local road systems only. When pipe-arch or elliptical shaped pipe is considered on a project, the designer should contact the Construction Division to obtain the cost and availability of material specific to a TDOT region.

Due to economic reasons, reinforced concrete pipe arches are available for use only in Region 4. Use of this pipe type will be very expensive in any other region. The Design Manager

supervising the design of the project may designate it on a case by case basis in Region 1, 2 and 3, realizing that the pipe must be transported from outside of these regions. Horizontal elliptical concrete pipe is available statewide, but may not be as economical as reinforced concrete pipe-arch in Region 4.

6.04.2.2 SELECTION OF LARGE PIPES VS. BOX CULVERTS

At locations requiring pipe sizes of 66 inches and greater, the designer should prepare a cost comparison for pipe vs. box culvert. The final choice between using a pipe or box culvert shall be made on the basis of hydraulics, traffic control, erosion control, vertical clearance and engineering economy. This cost comparison should be included in the project folder.

6.04.2.3 MINIMUM PIPE COVER

For all proposed culverts, the minimum cover for design loads should be not less than 12 inches. Minimum cover shall be measured from the top of a rigid pavement or the bottom of a flexible pavement to the top of the outside face of the proposed pipe. The footnotes to Table 6A-1 contain additional information on minimum allowable pipe cover.

6.04.2.4 SELECTION OF CULVERT SIZE

Usually, the most important factor governing the selection of culvert size will be its performance as determined by hydraulic analysis. Section 6.05 provides a detailed discussion of procedures for hydraulic analysis and this section provides guidance on the preparation and interpretation of hydraulic modeling.

6.04.2.4.1 MINIMUM PIPE SIZES

For all roadway classifications, the minimum allowable size for new circular pipe culverts shall be 18 inches. Horizontal elliptical pipes and pipe arches will also have a minimum rise of 18 inches.

When a project involves improvements to an existing roadway, the designer should give due consideration to replacing any pipes that do not meet the minimum size criteria; however, existing round pipes as small as 15 inches in diameter may be extended, provided that they offer sufficient hydraulic capacity.

6.04.2.4.2 INLET CONTROL VS. OUTLET CONTROL

The concept of flow control is central not only to the selection of culvert size, but also to the selection of culvert appurtenances as described in Section 6.04.3. The many different flow conditions that are possible in any given culvert may be classified into two categories depending upon the location of the control section.

1. **Inlet Control:** Inlet control occurs when the culvert barrel is capable of conveying more flow than the inlet will accept. This condition can occur only where the culvert has been constructed on a steep slope and the tailwater depth is relatively low. Under this flow condition, the culvert entrance is the control section, and critical depth will occur as the flow enters the barrel (see Figure 6-7). Flows downstream of the entrance will be in the supercritical flow regime. Because the performance of the culvert is determined at the

- culvert entrance, the headwater elevation will generally not be affected by changes in the tailwater condition.
2. **Outlet Control:** Outlet control generally occurs when the conveyance of the culvert barrel is less than the capacity of the inlet. Thus, the control section will be either the culvert barrel or the tailwater cross section. Because this condition usually occurs where the culvert has been constructed on a mild slope, flows in the barrel will be in the subcritical flow regime. If the tailwater depth is sufficiently low, critical depth will occur as the flow exits the culvert outlet. Where the tailwater depth is sufficiently high, the flow condition may be forced into outlet control, even for a steep culvert. Figure 6-8 illustrates submerged and un-submerged outlet flow conditions.

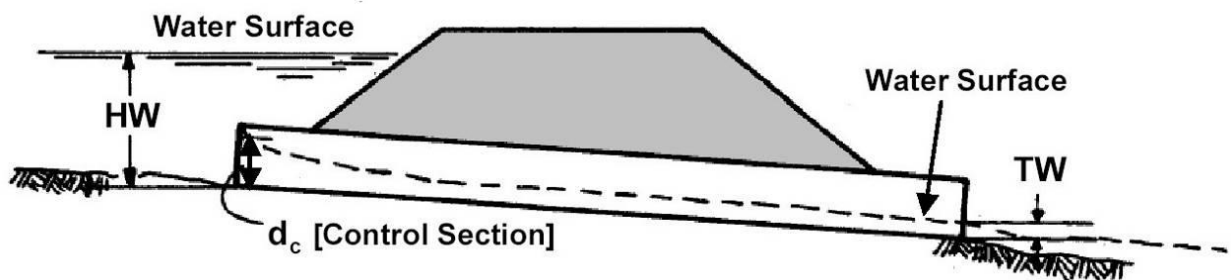

Figure 6-7
Inlet Control Flow Conditions

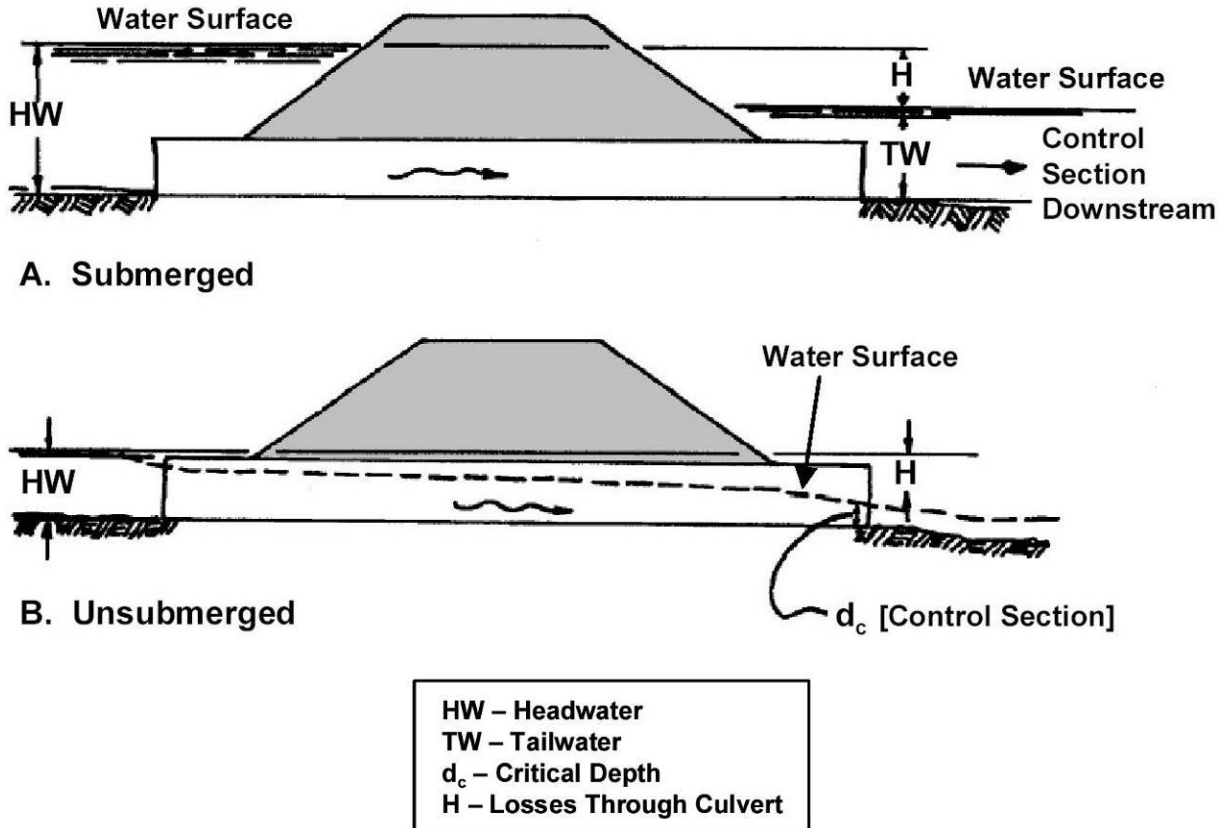

Figure 6-8
 Outlet Control Flow Conditions

6.04.2.4.3 CULVERT ROUGHNESS COEFFICIENTS

The hydraulic roughness or resistance to flow of any given culvert will be measured by the Manning’s n-value appropriate for the culvert material. For the purposes of determining the hydraulic roughness, four broad culvert categories can be defined as follows:

1. **Smooth Interior:** This category includes reinforced concrete pipes and pipe-arches, four-sided concrete boxes, polyvinyl chloride pipes and high-density polyethylene pipes with smooth liners. A Manning’s n-value of 0.013 should be used to analyze these pipes. This value accounts for the resistance of the smooth walls as well as turbulence which will occur at the pipe joints.
2. **Annular Corrugated Interior:** This category includes corrugated metal pipes, pipe-arches and high-density polyethylene pipes without liners, which are constructed with parallel rings. A Manning’s n-value of 0.024 should be used for these structures.
3. **Helical Corrugated Interior:** This category includes corrugated metal pipes which are constructed with spiral rings. When these structures flow full, the spiral corrugations tend to create a circular flow pattern that serves to reduce the effective roughness of the pipe

wall. However, when the structure flows partly full, this circular flow pattern will be less well-developed, and the effective roughness will be equivalent to that of a regular corrugated pipe. Because a culvert that is adequately sized will usually not flow full, even at the design flow rate, a Manning's n-value of 0.024 should be used for the design of these structures.

4. **Corrugated Structural Plate:** This category includes corrugated metal pipes and pipe-arches which are constructed from structural plates. N-values for these pipes should be in accordance with accepted engineering practice, and will normally range from 0.027 to 0.034.

6.04.2.4.4 ALLOWABLE HEADWATER ELEVATION

One of the most important parameters to be considered in evaluating the hydraulic performance of a given culvert size will be the headwater elevation it causes in the design flood. For a given structure type and end treatments, the designer should perform a hydraulic analysis for varying culvert sizes until the most economical size which yields an acceptable headwater elevation is determined.

Criteria for selecting the design storm frequency are provided Section 4.03 of this Drainage Manual. That section also states that the design headwater elevation should not significantly increase the flood hazard for adjacent property and that it should be at or below the bottom of the roadway subgrade. In addition to these requirements, the following guidelines should be followed for culvert design:

- For any project where an existing culvert is to be replaced, the performance of that culvert for the design discharge should be analyzed to determine the existing headwater elevation.
- The headwater created by a replacement culvert at the design discharge should be no greater than the headwater created by the existing culvert.
- For new alignment projects where a culvert is to be placed in a stream or sheet flow area, a reasonable effort should be made to determine the water surface elevation for the design flow prior to the project. The headwater elevation due to the new culvert should be no higher than the channel banks or no more than 1 foot above the pre-project water surface elevation, whichever is greater. The difference between the pre-project and post-project headwater surface elevations may be measured at the right-of-way line.

In remote rural areas where little or no damage will result from infrequent flooding, the criteria given in Section 4.03 may be somewhat relaxed to allow ponding outside of the right-of-way for the 50 year event. The Designer will be expected, however, to plot the water surface contour for all areas extending outside of the right-of-way on the drainage map and thoroughly research the area to determine the extent of damage to property. If it appears that this ponding will potentially result in appreciable damage to a building, frequently used driveway or annual crop land, every economically feasible effort shall be made to reduce the headwater elevation. If reducing the headwater is not economically viable, a permanent drainage easement shall be added to the Right-of-Way Plans.

For local roads in rural areas, the water surface that would occur in the 100 year event may be allowed to encroach on property or inundate the proposed roadway; however, where this

condition occurs, the consequences should be thoroughly explored and discussed with the Design Manager.

6.04.2.5 ALLOWABLE OUTLET VELOCITY

Since a culvert usually constricts the available channel area, flow velocities in the culvert are likely to be higher than in the channel. These increased velocities can cause streambed scour and bank erosion in the vicinity of the culvert outlet. Although the slope and roughness of the culvert barrel are the principal factors affecting the outlet velocity, selecting an arched shape or increasing the size of a culvert will occasionally allow for a more favorable outlet velocity. However, if a culvert has been sized properly according to allowable headwater criteria, it is almost always more economical to protect against excessive outlet velocity with riprap or another energy dissipation device than to adjust the culvert size. The use of riprap as scour protection at a culvert outlet is discussed in Section 6.04.3.3. Guidance for the design of energy dissipation structures is provided in Chapter 9 of this Manual.

Outlet velocity should be computed for a proposed culvert based upon the 50-year storm event. When alternate culvert materials are allowed at a site as specified in Table 6A-1, the computation of outlet velocity for a given culvert size should be based upon assuming a smooth interior.

To prevent scour or other damage to the interior of the culvert, culvert flow velocities greater than 20 feet per second should be avoided. On the other hand, velocities of less than 3 feet per second usually allow deposition of sediments within the culvert. Therefore, the minimum allowable culvert velocity should be 3 feet per second.

6.04.3 SELECTION OF APPURTENANCES

Culvert appurtenances include a wide variety of structural measures that may be added to the basic culvert to improve its performance, provide for increased traffic safety, or to reduce the maintenance required over the lifetime of the structure. While the majority of the structural measures discussed in this section will be applied at the ends of a culvert, a few will affect the basic structure of the culvert itself.

6.04.3.1 END TREATMENTS

End treatments for a culvert will consist of either an endwall or safety end section conformed to the slope of the roadway embankment. The choice of end treatment for a culvert will be determined by the type of facility being served, the culvert size, and whether the ends of the culvert are within the clear zone as defined in the TDOT Standard Roadway Drawings.

6.04.3.1.1 END TREATMENTS FOR CROSS DRAINS UNDER MAINLINE

All cross drains (perpendicular) placed under a mainline roadway, require type u endwalls conforming to the roadway fill slope as shown on standard drawings D-PE-15A through D-PE-48A for end wall geometry and D-PE-99 for grate details. All culvert endwalls located within the clear zone (S-CZ-1) require a safety grate (18" or 24" pipe enwalls may omit the steel grate). All cross drain culverts larger than 48" must be protected by a guardrail or end wall or must be placed outside the clear zone.

Cross drain end walls placed outside the clear zone may use type a (D-PE-1), type B (D-PE-9 thru 9F), or straight headwall (D-PE-4) in lieu of type U or if the pipe end wall is protected by a guardrail.

6.04.3.1.2 END TREATMENTS FOR SIDE DRAINS UNDER PUBLIC SIDE ROADS AND PRIVATE DRIVES

All side drains (parallel) placed under a side road, driveway, or field entrance, etc. that intersect a mainline roadway, require safety endwalls as shown on the D-SEW- series standard drawings with safety grate (D-SEW-1A) with a maximum 6:1 taper if the culvert endwalls are located inside the clear zone (S-CZ-1).

6.04.3.1.3 END TREATMENTS FOR MEDIAN CROSSOVERS

All median crossover side drains (longitudinal) placed under median openings require safety endwalls as shown on D-SEW- 12D standard drawing with safety grate (D-SEW-1A) with maximum 12:1 taper if the culvert endwalls are located inside the clear zone (S-CZ-1). If pipe end walls are protected by guardrail, then a safety end wall may be substituted by any other type U, A, B, or straight headwall types.

6.04.3.1.4 END TREATMENTS FOR CROSS DRAINS SKEWED TO THE ROADWAY

Type “U” concrete endwalls should be installed so that the surface of the endwall and its grate are flush with the face of the roadway embankment. Normally, this will require that the endwall be perpendicular to the centerline of the roadway. Where the cross drain will be skewed with respect to the roadway centerline, the designer will have two options for placement if the endwall. One option will be to extend or relocate the culvert so that the ends (the endwall) will be located outside of the mainline clear zone. The endwall would then be selected based upon the criteria provided above for each functional roadway classification with culvert ends outside of the clear zone.

The second option would be to connect the cross drain to the Type “U” concrete endwall at an angle as shown in Figure 6-9 and on Standard Drawing D-PE-99. The designer should ensure that the selected endwall will be sufficiently wide to accommodate the skewed width of the pipe. This is typically accomplished by selecting the next larger sized endwall. When this option is chosen, the designer should also recheck the hydraulic performance of the culvert, taking into account the additional head losses caused by the non-linear alignment. A procedure for this check is provided in Section 6.05.2.2.1.3.

For endwalls located within the mainline clear zone, culvert endwalls should be placed parallel to the roadway centerline so that the endwall slope matches the roadway slope. When a cross drain is skewed in relation to the roadway centerline, the designer should select one of the two options discussed above for providing an endwall treatment on the skewed pipe.

Improved inlets (discussed in the following section) should normally be perpendicular to the pipe. When an improved inlet is specified on a skewed pipe, the roadway fill slope will have to be transitioned (warped) to accommodate the improved inlet structure walls. If the improved inlet is within the clear zone, it should be protected with an appropriate roadside barrier (i.e. guardrail, etc.). When this is not feasible, then the option of extending the pipe beyond the clear zone should be considered.

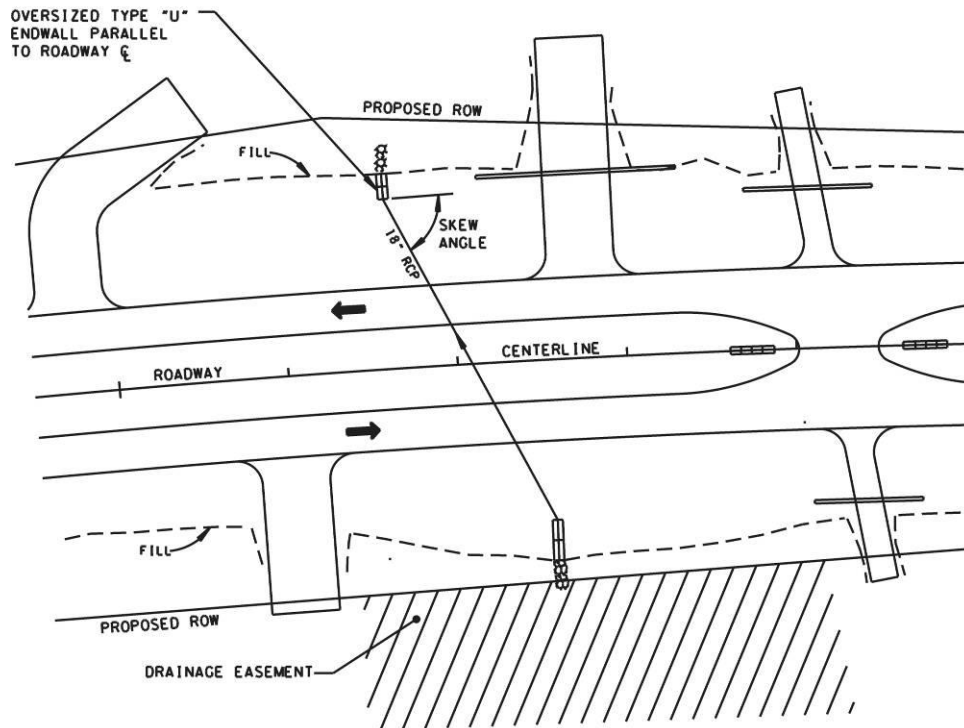

Figure 6-9
Skewed Culvert with Endwall Parallel to Roadway Centerline

6.04.3.2 IMPROVED INLETS

Culvert capacity is based on either culvert entrance conditions (*inlet control*) or barrel resistance (*outlet control*). Culverts in inlet control usually lie on steep slopes and flow only partly full. Under inlet control, the culvert barrel provides greater flow conveyance than the inlet. Thus, the culvert's capacity is determined by the opening area and configuration of the culvert entrance. An improved inlet usually provides an opening area greater than the area of the culvert barrel. Therefore, the capacity of a culvert operating under inlet control can be maximized by the use of an improved inlet.

An inlet improvement will allow for a reduced barrel size as compared to a culvert without an improved inlet. Under normal circumstances, the cost savings associated with the reduced barrel size will be greater than the cost of the improved inlet. The extent to which the barrel size can be reduced will depend upon site conditions as well as engineering judgment regarding the dependability of flood estimates and the allowable headwater elevation.

Improved inlets may also be constructed on existing culverts with inadequate capacity. This may avoid the entire replacement of a structure that is otherwise in good condition or the addition of a new parallel culvert.

Four types of inlet improvements may be considered:

1. **Bevel-edged inlets** are utilized on all Tennessee Department of Transportation standard box or slab-type culverts, as shown in the TDOT Standard Structure Drawings.
2. **Depressed inlets** normally consist of a sump constructed upstream of the culvert face. Usually the sump is paved, but for small depressions, lining the area with riprap will generally be adequate. A depressed inlet may allow for some reduction in culvert diameter as compared to a pipe at grade; however, this reduction may not be as great as could be accomplished with an improved inlet. Depressed inlets are described in detail in Section III of the FHWA Publication HDS-5.
3. **Side-tapered inlets** have an enlarged face area with tapering sidewalls that transition into the culvert barrel. They can provide as much as a 40 percent increase in flow capacity over that of conventional inlets.
4. **Slope-tapered inlets** provide a depression or fall in conjunction with a taper at the inlet. In some cases they can provide over 100 percent greater capacity than a conventional inlet. When specifying a slope-tapered inlet, the designer should include the cost of the required additional excavation in determining whether the proposed inlet will be cost effective. Further, the designer should verify that the velocity of flow in the culvert barrel will be at least three feet per second to minimize the potential for sedimentation. Slope-tapered inlets are shown in Figures 6A-4 and 6A-5 of the chapter Appendix.

Hydraulic design of improved inlets and the associated culvert barrels should be in accordance with the procedures provided in the FHWA publications *Hydraulic Design of Highway Culverts (HDS-5)* and *Hydraulic Design of Improved Inlets for Culverts (HEC-13)*.

The designer should be aware that not all culverts are candidates for an improved inlet. The selection of an improved inlet is governed by the following general guidelines:

1. The culvert must operate under inlet control and be at least 24 inches in diameter.
2. Improved inlets can present a maintenance problem in rural areas where the stream carries a significant debris load. The designer should carefully evaluate the size and type of debris which may occur at the site to insure that material will not become lodged in the throat of the improved inlet.
3. The cost of the culvert with the improved inlet and associated reduced barrel size must be less than the cost of a conventionally designed culvert. It has been found that the "break-even" point between the two options is often reached when the culvert length exceeds 90 feet. Therefore, inlet improvement should not be considered for culverts of less than this length.
4. The slope-tapered inlet is an additional improvement to the side-tapered design. Thus, it should be considered only for those sites at which a side-tapered inlet would not be suitable.
5. The relative costs of each possible inlet type should be compared to determine the most cost-effective option for a given site. Because no standard drawings exist for improved

inlets, an individual reinforced concrete design will be required. This will impose an additional cost to the project. A thorough evaluation of each alternative and its related costs should be conducted prior to the Right-of-Way Field Review, where the decision to add an improved inlet to the structure should be made. All data regarding the cost evaluation should be included in the project folder and be available for the field review.

6. Once a decision has been made to add an improved inlet to a culvert, the hydraulic design should be submitted to the Hydraulic Unit in the Structures Division for the needed reinforced concrete structural design.

6.04.3.3 RIPRAP SCOUR PROTECTION FOR CULVERT OUTLETS

Channel erosion frequently occurs at the outlet of a culvert due to plunging flow and the turbulence associated with flow expansion at that point. Riprap may be used to provide protection at a culvert outfall where such erosion is expected, regardless of the type of end treatment. The design of riprap at a culvert outlet should be in accordance with the following criteria:

1. Where the culvert outlet velocity, V_o , is less than 5 fps, it is generally not necessary to provide riprap erosion protection. However, the designer may choose to provide protection in areas where the channel is lined with highly erodible materials.
2. Riprap is required only where erodible materials are present. Where the channel bottom is composed of competent rock or is lined with large boulders, riprap will be required only along the sides of the channel.
3. Where V_o is between 5 and 12 fps, a riprap apron as shown in Figure 6-12 may be used to provide erosion protection, provided that the tailwater depth is at least 75% of the culvert brink depth, d_o , as described in the FHWA publication HEC-14, Section 10.
4. Where the tailwater depth is less than 75% of the culvert brink depth, a riprap apron should not be used to provide erosion protection. The needed protection may be provided by a riprap stilling basin or by some other type of energy dissipator.
5. It should be noted that Section 5.04.7.1.2 specifies that riprap should not be used where the channel velocity exceeds 12 fps. However, a riprap stilling basin may be used in any situation where the Froude Number of the culvert outflow, Fr_o , is less than or equal to 3.0, including those situations where the culvert outlet velocity, V_o , exceeds 12 fps. See Section 9.03.3.2 for more information.
6. The length of a riprap apron should be based on the difference between the culvert outlet velocity, V_o , and the natural channel velocity, V_n . In situations where the natural channel velocity is less than 5 fps, a natural velocity of 5 fps should be assumed in computing the apron length, unless highly erodible soils are present. Where it is necessary to extend the riprap apron past the limit of right-of-way, a permanent drainage easement should be established in accordance with Section 3.04.2. A procedure for computing the length of a riprap apron is provided in Section 6.05.5.
7. Riprap apron lengths greater than 50 feet are not desirable because such structures would add complexity in obtaining environmental permits.

8. The type of riprap used to construct an apron should be selected based upon the culvert outlet velocity in accordance with the following:
 - Machined Riprap (Class A-1) should be used where erosion protection is desired and the culvert outlet velocity is 5 fps or less
 - Machined Riprap (Class B) should be used where the culvert outlet velocity is greater than 5 fps, up to 10 fps
 - Machined Riprap (Class C) should be used where the culvert outlet velocity is greater than 10 fps, up to 12 fps
 - Classes of riprap other than those listed above should not be used without the permission of the Design Manager

• The designer should additionally refer to Section 9.03.1 for more detailed criteria for the use of energy dissipators.

6.04.3.4 DEBRIS CONTROL

When selecting a debris control method, the designer should carefully consider the size, type and quantity of debris expected at the culvert site as well as the potential for flood damages due to clogging at the culvert. Although debris can be controlled by means of a structure that will intercept or deflect it, every reasonable effort should be made to provide a culvert design that will allow for the passage of debris. Over the life of the structure, the maintenance costs associated with periodically removing intercepted debris from the structure site will be significantly greater than the additional cost required to provide a structure that is able to pass debris without clogging.

At sites where a significant debris load is anticipated, one or more of the following strategies should be employed:

1. **Provide a single opening:** Multiple-cell box culverts and multiple-pipe installations usually create a blockage in the middle of the waterway that will catch debris. Large debris accumulations at these sites can seriously impede the flow of water and create localized erosion problems or other maintenance issues. A single opening should always be provided where debris is expected unless an economic analysis demonstrates that the construction cost savings will outweigh the long-term cost of maintenance.
2. **Increase the waterway opening size:** Occasionally, a small increase in structure size over what is necessary for hydraulic capacity will aid in the passage of debris. This option would be particularly useful where the culvert length is relatively small. The designer should consider the nature of debris sources in the watershed and the width and depth of the floodplain at the design flow rate.
3. **Provide a sloped end-treatment:** Type "U" and "SD" concrete endwalls with or without grates will tend to control the size of debris that is allowed to enter the culvert barrel. Further, any debris snagged on the endwall will tend to be pushed up the roadway embankment by the force of the flowing water, leaving the waterway area largely unblocked. When safety requires that this type of endwall be provided at the downstream end of culvert with a grate, a matching endwall and grate should be installed at the upstream end of the culvert. This will help to insure that debris will not become lodged

inside of the grate at the downstream end of the culvert, where it would pose a significant maintenance problem.

4. **Avoid the use of improved inlets:** Particularly in inaccessible or rural areas, debris can become a serious maintenance problem for an improved inlet because the face of the inlet is larger than the culvert barrel. Thus, there is a tendency for debris to become lodged in the throat of the inlet. As smaller debris continues to catch on the original blocked material, a severe blockage can result.
5. **Provide a trash rack or debris deflector:** These types of structures are intended to catch debris upstream of the culvert inlet or to push it to the side of the waterway where it will not obstruct flows. This option should not be used unless no other option is available. When specifying one of these structures, the designer should provide adequate access for maintenance and ensure that the structure is located outside of the clear zone of any mainline roadway. The FHWA document HEC-9 contains guidance for the design of these debris control structures.
6. **Provide a means of access for maintenance:** A few of the options discussed above are designed to trap or deflect debris before it enters the culvert. Where these means are to be employed, the designer should ensure that the Maintenance Division will have adequate access to the culvert inlet to facilitate the removal of any accumulated debris. In general, it should be possible to drive a truck to within a reasonable proximity of the culvert inlet.

6.04.3.5 STOCK PASSES

The Department policy regarding stock passes is to provide a livestock pass when such a structure can be economically justified. The justification will be developed by the Office of Right-of-Way and a directive provided to incorporate justified stock passes. Generally, the inclusion of these facilities can be done at any point in the plans development process, but a determination shall normally be made prior to the plans being issued for all incidentals except appraisals.

In certain situations, the actual justification for a stock pass may not be developed at an early stage of plan development. The location and design of stock passes in these situations may be a part of the plan development, but an appropriate "Note" is to be affixed to the plans indicating that justification for inclusion is pending. In these cases, the Office of Right-of-Way, in coordination with the Design Division, will secure the appropriate justification/approvals prior to finalization of the Construction Plans.

A 6-foot x 6-foot reinforced concrete box culvert is to be used as the standard stock pass. If the structure use is wholly for livestock passage, then "stock pass" shall be indicated on the profile. If the structure is to be used partially for a stock pass and partially for drainage, then the appropriate drainage information and "stock pass" shall be indicated on the profile.

SECTION 6.05 – DESIGN PROCEDURES

The design procedure detailed in this section provides a convenient and organized method for designing culverts by hand for a constant discharge. This procedure follows the methods and design charts that are presented in the F.H.W.A. publication HDS-5, *Hydraulic Design of Highway Culverts*. However, only the Culvert Design Form from that publication is reproduced in this manual; the remaining charts and nomographs are not. Thus, the designer should have a copy of the HDS-5 publication available before attempting to carry out this procedure.

The designer should possess an understanding of culvert hydraulics and be familiar with the equations presented in HDS-5 for the analysis of flows through a culvert. Without an understanding of the application of this procedure, or any other culvert design method, a structure design that is inadequate, unsafe or unduly costly could result.

The computer program HY-8 automates the procedure presented in this section. Design examples using hand computations and HY-8 are presented in the Appendix along with a flow chart to be used in the culvert design process.

6.05.1 ASSEMBLE DATA

The data required to support a culvert design have been described in detail in Section 6.03. As a first step in the culvert design, pertinent portions of this data are entered into the top section of the Culvert Design Form (See Figure 6A-2). Data that should be assembled to support the design include the following:

- Existing and proposed site data – see Sections 6.03.2 and 6.03.3
- Design criteria – see Section 6.04
- Hydrology and flow rates – see Sections 4.04 and 6.04.2.1
- Design tailwater elevation – see Sections 6.03.1.4 and 5.05.3.3

6.05.2 CULVERT SIZING PROCESS

For each of the culvert types allowable at a given site, a series of trials will be run until the most economical size (usually the smallest) that meets the required design criteria is determined. Each trial will consist of computing the hydraulic performance of the trial culvert size combined with the appropriate end treatment. Where more than one end treatment is possible, the designer should determine the most economical combination of culvert end treatment. Most often, the hydraulic performance of a given culvert will be evaluated by the headwater elevation necessary for the structure to pass the design discharge. To completely assess the performance of the culvert, it will be necessary to determine the headwater elevation for both inlet control and outlet control.

6.05.2.1 DETERMINE THE INLET CONTROL HEADWATER DEPTH, HW_i

The headwater elevation that would be created by the proposed culvert operating in inlet control may be determined as follows:

Step 1: Select the inlet control nomograph from HDS-5, Appendix D that corresponds to the proposed culvert type and inlet condition (Note: A photocopy should be used for marking so that the original nomograph may be preserved).

Step 2: Locate and mark the diameter or height of the culvert on the scale on the left side of the nomograph.

Step 3: Locate and mark the design discharge on the scale on the center of the graph. For box culverts, mark the flow per unit width (Q divided by the box width).

Step 4: Extend a straight line from the culvert size through the discharge to the first scale of the group of scales on the right side of the nomograph.

Step 5: Extend a horizontal line across the three scales and read a value for HW / D from the scale that corresponds to the inlet condition of the proposed culvert.

- HW = headwater depth, (ft)
- D = diameter of a circular culvert or rise of a box culvert, (ft)

Step 6: Multiply HW / D by the diameter or rise to obtain the HW elevation at the energy grade line.

- If the approach velocity is neglected, $HW_i = HW$
- If the approach velocity is considered, $HW_i = HW - (\text{approach velocity head})$

6.05.2.2 DETERMINE THE OUTLET CONTROL HEADWATER DEPTH, HW_o

The headwater elevation that would be created by the proposed culvert operating in outlet control may be determined by the process described in this section. The designer should keep in mind that the nomographs presented in HDS-5 are intended for culverts flowing full. Thus, they may be of limited value where this assumption is violated.

An approximate method has been developed so that the nomographs can be applied where the culvert flows partly full, with the inlet submerged and the outlet un-submerged. Based on numerous backwater calculations by the F.H.W.A., it has been determined that a projection of the full-flow hydraulic grade line will cross the plane of the culvert outlet at a point half way between critical depth and the top of the barrel. This depth is computed as the sum of the critical depth and the diameter (or rise) of the culvert divided by 2 (see Step 2, below). However, the application of this method is also limited, as described in Step 13. Terms used in the computational process are provided in Figure 6-10.

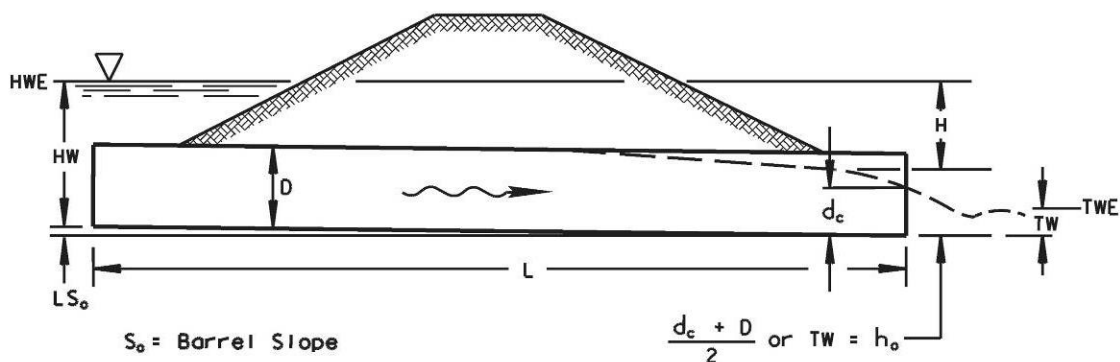

Figure 6-10
Outlet Control Headwater Depth H_{w_o}

Step 1: Compute the tailwater depth, TW, by subtracting the elevation of the culvert outlet from the tailwater elevation determined in the downstream channel analysis.

Step 2: Determine the critical depth, d_c , in the culvert. Tables 6A-7 through 6A-10 in the Appendix provide critical depth values for various discharges in a variety of non-rectangular structures. Values may be interpolated as needed. Critical depth in a four-sided box culvert can be computed as:

$$d_c = 0.315 \left(\left(\frac{Q}{B} \right)^2 \right)^{0.333} \quad (6-1)$$

Where:

- d_c = critical depth, (ft)
- Q = design discharge or flow rate, (ft^3/s)
- B = bottom width of the box, (ft)

- Note that d_c cannot be greater than the rise of the culvert
- Critical depth nomographs for culvert shapes not found in the Appendix of this chapter are provided in HDS-5, Appendix D

Step 3: Compute the quantity $(d_c + D) / 2$

Step 4: Determine the quantity h_o (see Figure 6-10) as the greater of TW or $(d_c + D) / 2$

Step 5: Determine the entrance loss coefficient, K_e , from Table 6A-6.

Step 6: Select the outlet control nomograph from HDS-5, Appendix D that corresponds to the proposed culvert shape and Manning's n-value.

Step 7: Locate and mark the culvert length, L, on the appropriate K_e scale in the middle of the nomograph.

- The culvert length, L, may be used if the culvert n-value matches the n-value given on the nomograph
- If the n-value for the culvert does not match the n-value on the nomograph, an adjusted length L₁, must be entered on the K_e scale
- The adjusted length is computed as:

$$L_1 = L \left(\frac{n_1}{n_2} \right)^2 \quad (6-2)$$

Where: L₁ = adjusted culvert length, (ft)
 L = actual culvert length, (ft)
 n₁ = actual culvert Mannings n-value, (dimensionless)
 n₂ = Manning's coefficient given on the nomograph, (dimensionless)

Step 8: Extend a straight line from the culvert length marked on the K_e scale to the appropriate culvert size on the second scale from the left of the nomograph.

Step 9: Locate and mark the design discharge on the scale on the left side of the nomograph.

Step 10: Extend a second line from the marked discharge through the intersection of the first line and the turning line to the head, H, scale on the right side of the nomograph. Read and record the value of H.

Step 11: The headwater elevation upstream of the culvert is computed as:

$$HWE = \text{Culvert outlet elevation} + h_o + H \quad (6-3)$$

Where: h_o = corresponds to the tailwater depth, (ft)
 H = corresponds to the head losses through the culvert due to barrel friction and inlet losses, (ft)

Step 12: The headwater depth, HW_o, is computed as HWE minus the elevation of the culvert inlet.

Step 13: Evaluate the computed headwater depth to insure that the nomographic method is applicable:

- If HW_o is less than 1.2 times the culvert diameter and outlet control is assumed, the barrel may flow partly full. Further, the approximate method of using the greater of TW and (d_c + D) / 2 may not provide a reliable result. Backwater computations through the culvert should be used to check the nomograph results.
- The nomographs may not be used where HW_o is less than 75% of the culvert diameter. In this case, backwater computations will provide the only reliable analysis.

6.05.2.2.1 OPTIONAL OUTLET CONTROL HEADWATER COMPUTATIONS

Under certain circumstances, it may not be desirable to use HDS-5 outlet control nomographs even when they are applicable as described in Step 13 of the previous section. The following sections describe three such situations, and present equations that may be used to compute the headwater depth for outlet control.

6.05.2.2.1.1 FLOW CONDITIONS OUT OF THE RANGE OF THE NOMOGRAPHS

Occasionally, the culvert size, inlet condition or some other hydraulic characteristic of the site will be other than what is covered on the outlet control nomograph. Neglecting velocity head, the headwater depth at the culvert may be computed as:

$$HW_o = h_o + h_L \tag{6-4}$$

Where: HW_o is described in Step 12 of Section 6.05.1.2
 h_o is described in Step 4 of Section 6.05.1.2
 h_L = energy losses through the culvert, (ft)

For the purpose of this computation:

$$h_L = h_e + h_f \tag{6-5}$$

Where: h_e = energy loss at the entrance, (ft)
 h_f = energy loss due to friction through the culvert barrel, (ft)

and h_e may be computed as:

$$h_e = K_e \left(\frac{V_i^2}{2g} \right) \tag{6-6}$$

Where: K_e = entrance loss coefficient from Table 6A-6
 V_i = velocity at the inlet, in this case the full-flow velocity, (ft/s)
 g = acceleration due to gravity, (32.2 ft/sec²)

and, h_f may be computed as:

$$h_f = \left(\frac{29.16n^2L}{R^{1.33}} \right) \left(\frac{V_i^2}{2g} \right) \tag{6-7}$$

Where: n = Manning's coefficient of channel roughness, (dimensionless)
 L = culvert length, (ft)
 R = hydraulic radius of the culvert flowing full, (ft)
 V_i = velocity at the inlet, in this case the full-flow velocity, (ft/s)
 g = acceleration due to gravity, (32.2 ft/sec²)

6.05.2.2.1.2 HEAD LOSSES AT END TREATMENTS

Type “U” concrete endwalls for pipes 30 inches or more in diameter provide for end grates that include a vertical bar. Although it would seem intuitively that these grates should create significant head losses, research into this question has indicated otherwise. One of these studies examined grated culvert end sections used by the Kansas Department of Transportation (K-TRAN). This study determined entrance loss coefficients, K_e , for these end sections, which have openings narrower than the culvert diameter. The results of the K-TRAN study may be extrapolated for TDOT standard endwalls by assuming that the end section opening width is equal to the diameter of the pipe. This yields a value of 0.5 for K_e , which is equal to the value recommended in Table 6A-6 for a fabricated end section conforming to the fill slope. The K-TRAN study further indicates that the arrangement of the bars on an end section does not have a significant impact on the hydraulic performance of the culvert.

The FHWA publication HDS-5 offers a method for computing the head losses at a vertical bar at an end treatment (*see page 170, 2001 ed.*). Application of this method to TDOT standard endwalls will yield insignificant head losses for velocities up to 10 feet per second.

In general, head losses which occur at grates on Type “U” concrete endwalls may be neglected. An entrance loss coefficient of 0.5 should be used for these endwalls regardless of whether grates are present.

6.05.2.2.1.3 HEAD LOSS AT SKEWED END TREATMENTS

As described in Section 6.04.3.1.5, Type “U” endwalls should be installed flush with the face of the roadway embankment. In situations where the culvert must be installed at a skew to the roadway, the endwalls will be connected to the pipe at an angle, resulting in bends in the horizontal alignment. When the culvert operates under outlet control, it may be necessary to account for the additional head losses created by these bends. The procedure provided below assumes that the losses at endwall bends will be similar to head losses in pipe bends, as described in HDS-5. It should be noted that head loss in a bend is directly related to the radius of the bend with respect to the pipe diameter. However, the radius of curvature is somewhat difficult to define for a skewed endwall connection. Thus, the following procedure is based upon the “worst case” included in HDS-5, in which the radius is equal to the pipe diameter:

Step 1: Determine the inlet and outlet control headwater depths as described in this section. The culvert length may be assumed to include the length of the endwalls. If the inlet control headwater depth is greater than the outlet control headwater depth, no further action is required.

Step 2: The bend losses may be determined by multiplying a bend loss coefficient, K_b , by the velocity head at the culvert inlet and outlet. Where there are endwalls at both ends of the culvert, the losses at each end should be determined and added to the overall outlet control head loss for the structure. If one end of the culvert does not include an endwall, bend loss computations would not be required for that end. A value of K_b may be determined from Table 6-3, based upon the skew angle between the pipe and the endwall:

| Angle (degrees) | K _b |
|-----------------|----------------|
| 90 | 0.50 |
| 60 | 0.43 |
| 45 | 0.37 |
| 22.5 | 0.25 |
| 15 | 0.18 |
| 10 | 0.10 |
| 5 | 0.00 |

Table 6-3
K_b Values for Skewed Endwalls
Adapted from HDS-5

Step 3: Where there is an endwall at the downstream end of a culvert, determine the outlet flow velocity, V_o, using the procedure provided in Section 6.05.4. The bend loss may then be computed as:

$$h_{bo} = K_b \left(\frac{V_o^2}{2g} \right) \tag{6-8}$$

Where: h_{bo} = bend loss at the outlet, (ft)
 K_b = bend loss coefficient
 V_o = outlet velocity, (ft/s)
 g = acceleration due to gravity, (32.2 ft/sec²)

Step 4: Estimate the inlet depth as the lesser of the headwater depth and the culvert rise, and determine the flow area, A_i, at the inlet. Table 6A-11 provides a means of computing the flow area of a partially full circular cross section, and may be used to determine A_i where the depth is less than the diameter. The flow velocity at the inlet, V_i, may then be computed by dividing the design flow rate by A_i.

Determine the bend loss at the culvert entrance as:

$$h_{bi} = K_b \left(\frac{V_i^2}{2g} \right) \tag{6-9}$$

Where: h_{bi} = bend loss at the inlet, (ft)
 K_b = bend loss coefficient
 V_i = inlet velocity, (ft/s)
 g = acceleration due to gravity, (32.2 ft/sec²)

Step 5: Determine the corrected value for the headwater elevation (HWE) by adding h_{bo} and h_{bi} to the headwater value found in Step 1.

6.05.2.2.1.4 ACCOUNTING FOR VELOCITY HEAD

The HDS-5 nomographs or the equations presented in the preceding sections are used to determine the head loss from the downstream end of the culvert to the upstream end. Because head is an energy term, these methods return the difference in energy grade line elevation, as opposed to the difference in water surface elevation. It is assumed in the use of these methods that the velocity head may be neglected. That is, the channel flow velocities upstream and downstream of the culvert are sufficiently small so that the term $(V^2/2g)$ may be neglected, thus making the water surface elevation approximately equal to the energy grade line. However, when the velocity head becomes a significant factor, the actual water surface elevation will be somewhat lower than the elevations determined by these methods. To account for this, the energy balance through the culvert may be re-written as:

$$HWE + \frac{V_u^2}{2g} = TWE + \frac{V_d^2}{2g} + h_L \quad (6-10)$$

Where:

- HWE = headwater surface elevation, (ft)
- g = acceleration due to gravity, (32.2 ft/sec²)
- V_u = velocity of channel flow upstream of the culvert, (ft/s)
- TWE = as defined in the following paragraph, (ft)
- V_d = velocity of channel flow downstream of the culvert, (ft/s) (see note below)
- h_L = head loss through the culvert, (ft) (see Section 6.05.2.2.1.1)

Equation 6-5 would normally be used in the determination of the term h_L in Equation 6-10. However; Equation 6-5 is based upon an assumption of full flow through the culvert, which occurs infrequently at sites where the channel flow velocities are high. Thus, the designer should first determine the quantity h_o , as described in Steps 1 through 4 of Section 6.05.2.2. If h_o is equal to the tailwater depth in the channel, then TWE would be equal to the tailwater elevation and V_d would be equal to the flow velocity in the downstream channel. However, when h_o is determined by $(d_c + D) / 2$, TWE would be equal to h_o plus the culvert invert elevation and V_d would be the full flow velocity through the culvert.

It should be noted that the use of $(d_c + D) / 2$ to determine the tailwater elevation represents an approximate solution subject to the limitations described in Step 13 of Section 6.05.2.2.

6.05.2.3 DETERMINE THE CONTROLLING HEADWATER DEPTH

The performance of the culvert being analyzed will be determined by comparing HW_i (Section 6.05.2.1) and HW_o (Section 6.05.2.2). The greater of the two is termed the controlling headwater elevation.

The headwater elevation determined for the proposed culvert at the design discharge is then checked against the allowable headwater elevation to determine whether the proposed design is acceptable. If not, a different culvert size is chosen and the analysis is repeated.

6.05.3 COMPUTATION OF ROADWAY OVERFLOW

The methods presented in Section 6.05.2 did not account for the possibility of roadway overflow in the culvert analysis. When the analysis of a culvert indicates that the controlling headwater elevation will be greater than the lowest point on the roadway, it will be necessary to determine what portion of the flow passes over the roadway. Determining the flow split between the culvert and roadway is an iterative procedure and may be accomplished as follows:

Step 1: Analyze the performance of the culvert for the design discharge without considering roadway overflow to determine the tailwater elevation and to verify that the controlling headwater elevation will be above the roadway.

Step 2: Assume an upstream depth over the roadway HW_r . This will normally be much less than the depth corresponding to the controlling headwater depth determined in Step 1.

Step 3: Project the assumed HW_r onto the roadway profile to determine the total length along the centerline of the roadway over which flows will pass, L_w . As shown in Figure 6-11, this entire length will be assumed to act as a weir.

Step 4: Because the roadway embankment will act as a broad-crested weir, it is important to find the width of the weir from the upstream side of the roadway to the downstream side, L_r . This distance will then be used to determine the weir coefficient, C_d , for roadway overflow in the following manner:

- Compute the ratio HW_r / L_r , where HW_r is the headwater depth above the roadway and L_r is the width of the weir from the upstream side to the downstream side of the roadway embankment. This ratio is used with Figure 6A-3 in the Appendix to determine the roadway overtopping discharge coefficient C_r . Where HW_r / L_r is greater than 0.15 use graph "A" on Figure 6A-3, and where HW_r / L_r is less than 0.15, use graph "B."
- If the tailwater elevation determined in Step 1 is greater than the roadway elevation, C_r must be adjusted for submergence by a factor termed k_t . To determine the degree of submergence, the ratio h_t / HW_r is computed, where h_t is the height of the tailwater over the roadway. Once this ratio has been computed, use graph "C" on Figure 6A-3 to determine k_t .
- When k_t is less than 1.0, $C_d = C_r k_t$. Otherwise, $C_d = C_r$.

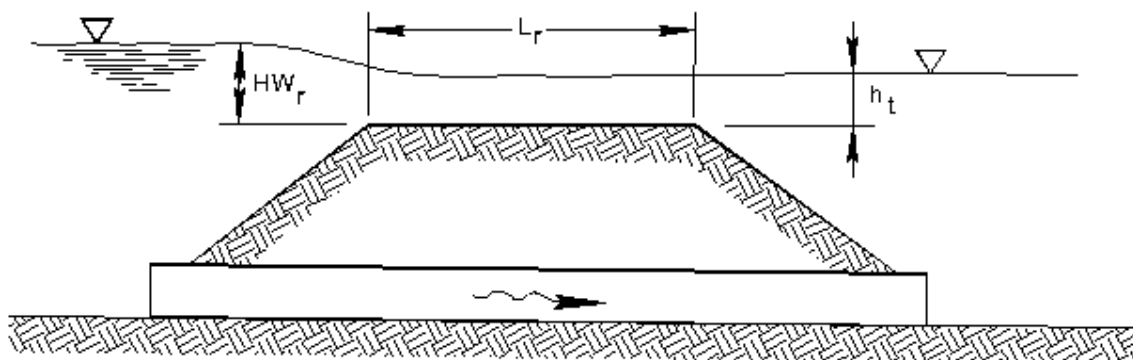

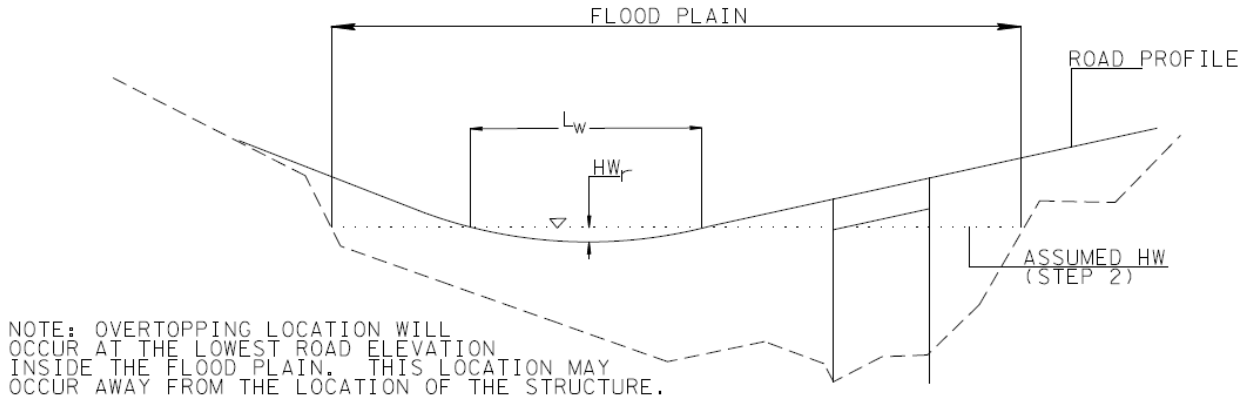

Figure 6-11
Coefficients for Roadway Overtopping

Step 5: Determine the effective head acting on the broad-crested weir that is formed by the roadway. HW_r is equal to the depth of flow at the lowest point in the roadway profile; and is thus the maximum depth on the weir. Because depth is not constant across the entire length of the weir, it is necessary to adjust HW_r by a factor termed C_e to account for the fact that the effective head over much of the weir length will be less than HW_r . The flow rate over the roadway is thus computed as:

$$Q_r = C_d L_w (C_e HW_r)^{1.5} \quad (6-11)$$

Where:

- Q_r = flow rate over the roadway, (ft³/s),
- C_d = weir coefficient, as determined in Step 4
- L_w = weir length along the roadway centerline, determined in Step 3, (ft)
- C_e = adjustment for the effective weir head
- HW_r = depth of the assumed headwater elevation on the roadway, (ft)

The parameter C_e will vary somewhat depending upon the configuration of the roadway and the actual depth of the roadway overflow. However, a constant value of 0.65 may be assumed without significantly affecting the accuracy of the computations.

Step 6: The flow rate through the culvert is then computed as $Q_{culv} = Q_{design} - Q_r$

Step 7: The culvert performance is then evaluated using Q_{culv} as described in Section 6.05.2. It should be noted that, since Q_{culv} is no longer Q_{design} , the quantity $(d_c + D)/2$ should also be recomputed.

Step 8: Compare the controlling headwater elevation determined for the culvert to the elevation corresponding to HW_r . If the two elevations are acceptably close, the analysis is finished. Otherwise, the designer must assume a new HW_r and return to Step 3.

6.05.4 COMPUTE OUTLET DEPTH AND VELOCITY

The first step in determining outlet conditions will be to determine the outlet depth, d_o . Once that has been determined, it will then be possible to compute the flow area and outlet velocity. The process used to determine the outlet depth will depend upon whether the structure is flowing in inlet or outlet control.

If the structure is in inlet control, flows in the culvert will be supercritical and will usually not be affected by tailwater. The outlet depth may thus be determined in the following manner:

- Determine the normal depth of flow in the culvert using Manning’s Equation and the design discharge.
- If the length of the culvert is greater than 50 times the normal depth, d_o will be considered to be equal to the normal depth. If not, d_o may be determined only by performing backwater computations through the culvert.

If the structure is in outlet control, d_o may be affected by the tailwater elevation. It will be necessary to first determine the critical depth of the flow in the culvert. The critical depth will then be compared to the tailwater depth to determine the control point:

- If the critical depth is greater than the tailwater depth, d_o will be considered to be equal to the critical depth. It should be noted that when this condition exists, the actual section where the critical flow condition will occur will be somewhat upstream of the actual culvert outlet, resulting in a depth at the brink that is somewhat lower than critical depth. However, the difference between the critical and brink depths is normally sufficiently small that it may be neglected.
- If the tailwater depth is greater than the critical depth and below the top of the culvert opening, d_o will be equal to the tailwater depth.
- If the tailwater depth is greater than the top of the culvert opening, d_o will be equal to the top of the culvert opening.

The flow area, A_o , corresponding to d_o may be determined by the use of Table 6A-11. The outlet velocity may then be computed as:

$$V_o = \frac{Q}{A_o} \tag{6-12}$$

Where: V_o = outlet velocity, (ft/s)
 Q = design discharge or flow rate, (ft³/s)
 A_o = outlet flow area, (ft²)

6.05.5 RIPRAP APRON DESIGN

As described in Section 6.04.3.3, a riprap apron may be used downstream of a culvert outfall to protect the streambed from scour. The typical geometry of these aprons is shown in Figure 6-12. The length and other dimensions of an apron may be designed using the following procedure:

Step 1: Determine the flow depth, d_o , and velocity, V_o , at the culvert outlet using the procedure provided in Section 6.05.4.

Step 2: Compute the effective diameter, D_{eff} , of the flow at the culvert outfall. If the culvert is flowing full at the outfall, $D_{eff} = D_o$ (the culvert diameter). Otherwise, D_{eff} will be the diameter of a circle with an area equal to the flow area at the culvert outfall. Once d_o has been determined, the ratio d_o / D_o may be computed. Using this ratio, a value for the ratio A_o / A_f may be interpolated from Table 6A-11, where A_o is the area of the flow at the culvert outfall and A_f is the area of the culvert flowing full. From this, it is possible to determine the flow area at the outfall (A_o). The effective diameter may then be computed from:

$$D_{eff} = \left(\frac{4A_o}{\pi} \right)^{0.5} \quad (6-13)$$

Step 3: Compute the ratio V_n / V_o , where V_n is the natural channel velocity and V_o is the flow velocity at the culvert outfall, computed in Step 1. Based upon the value of this ratio, a value for the ratio of the apron length L_a to the effective outflow diameter D_{eff} may be computed from one of the two following equations:

When V_n / V_o is greater than or equal to 0.6, L_a / D_{eff} should be computed from:

$$\frac{L_a}{D_{eff}} = 19.612 \left\{ \left[1.053 - \left(\frac{V_n}{V_o} \right) \right]^{0.5} - 0.171 \right\} \quad (6-14)$$

When V_n / V_o is less than 0.6, L_a / D_{eff} should be computed from:

$$\frac{L_a}{D_{eff}} = 5.933 \left(\frac{V_n}{V_o} \right)^{-1.005} \quad (6-15)$$

Where: L_a = apron length, (ft)
 D_{eff} = effective diameter of the culvert outflow, determined in Step 2, (ft)
 V_n = natural channel flow velocity **or** 5 fps, whichever is greater
 V_o = flow velocity at the culvert outfall, (ft/s)

Figure 6A-10 in the Appendix, may be used in place of the equations presented above.

Step 4: Determine the width of the apron at the end of the apron based upon Figure 6-12. The class of riprap to use may be selected based upon the guidance provided in Section 6.04.3.3.

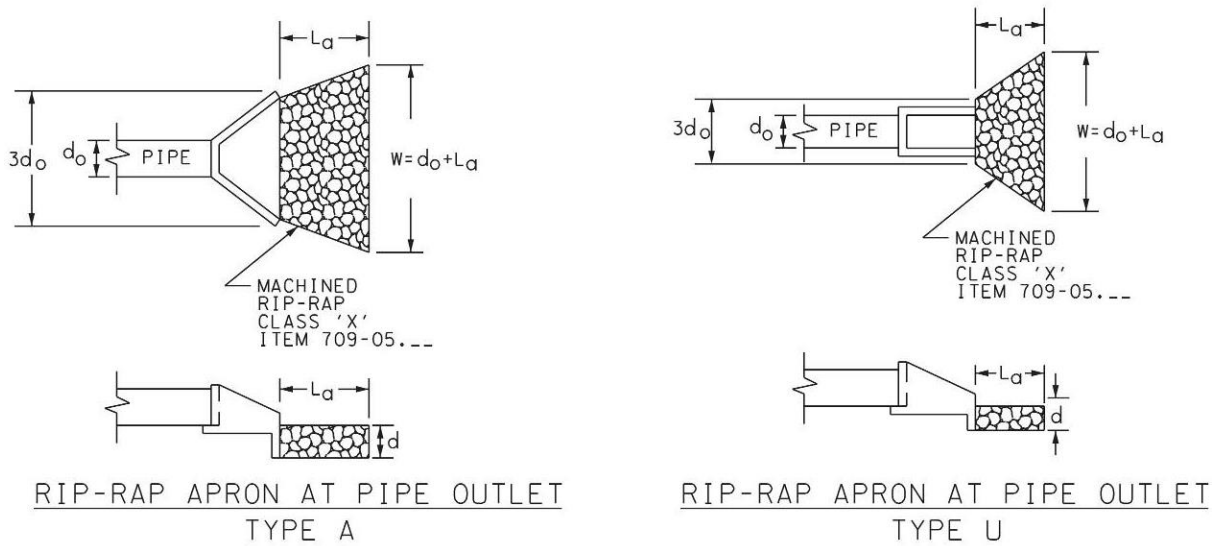

Figure 6-12
Definition Sketch for Riprap Apron Dimensions

6.05.6 DESIGN OF “BROKEN BACK” CULVERTS FOR VELOCITY CONTROL

As described in Section 6.04.1.1.1.4, it is possible to use a “broken-back” alignment for a box culvert on a steep slope to reduce the velocity at the outlet. Normally, this procedure would be used where the culvert proposed for a site has resulted in very high outlet velocities, resulting in the need for an energy dissipator. The “broken-back” alignment may then be investigated as a means to reduce or eliminate the need to provide an energy dissipator. Thus, the procedure provided in this section assumes that designs for a straight culvert and energy dissipator have already been determined for the site, and that the “broken-back” alignment is being investigated as an alternative.

The hydraulic analysis of this type of “broken back” culvert can be very complex because it involves consideration of both energy and momentum principles. This section provides a simplified procedure which may be used to achieve an effective design with a minimum of analysis. This method divides the proposed culvert into two sections which are analyzed separately.

Step 1: Determine the headwater depth for the proposed culvert by analyzing the steep portion of the facility as a “stand-alone” culvert. This segment of the culvert should have a supercritical slope for the design discharge and will thus operate under inlet control. If it is found that the upper section does not operate under inlet control, the design of the facility should be adjusted. The tailwater depth should be assumed to be at or below the bottom of the culvert. The size of the culvert should be adjusted until the design headwater elevation is achieved. See Section 6.04.2 for further information.

Flow conditions should also be determined at the end of the steep portion of the culvert as if it were a culvert outfall. The depth, d_u , and velocity, V_u , of flow should be determined using

the procedures provided in Section 6.05.4. The Froude Number of the flow, Fr_u , should also be determined as described in Section 9.04.1.2.

Step 2: Analyze the hydraulic performance of the lower segment of the culvert as a separate culvert to determine the outlet velocity, V_o . The tailwater depth used in this analysis should be based upon the actual downstream conditions. In many cases it may be found that the outlet velocity is greater than 5 fps, requiring that a riprap apron or basin be provided at the culvert outlet as described in Section 6.04.3.4.

A headwater elevation for the downstream portion of the culvert, HW_d , should also be determined in this step. This represents the headwater elevation that would occur at the downstream portion of the culvert if the upstream steep portion were not present.

Step 3: “Broken-back” culverts achieve velocity control by forcing a hydraulic jump within the culvert so that flows at the culvert outlet will be in the subcritical flow regime. Where the headwater depth for the lower segment of the culvert is sufficiently high, the hydraulic jump will occur in the steep portion of the culvert. Where this is not the case, it will be necessary for the hydraulic jump to occur in the lower portion of the culvert. However, in many cases, the momentum of the water in the steep portion of the culvert is so great that the flow will continue in the supercritical flow regime all the way to the culvert outlet. Thus, it becomes necessary to check whether the hydraulic jump will occur in the steep portion of the culvert.

A hydraulic jump will occur in the upper portion of the culvert where the headwater elevation for the lower portion, HW_d , is greater than the depth sequent to the supercritical flow depth at the end of the upstream portion, d_u . This sequent depth, d_{u2} , may be computed from:

$$d_{u2} = 0.5d_u \left(\sqrt{1 + 8Fr_u^2} - 1 \right) \quad (6-16)$$

Where: d_{u2} = depth sequent to the flow depth at the end of the steep section, (ft)
 d_u = depth at the end of the steep section, (ft)
 Fr_u = Froude Number of the flow at the end of the steep section

Where HW_d is greater than d_{u2} , the designer may skip to Step 5. Otherwise, the process should continue with Step 4.

Step 4: In situations where the flow will be supercritical in the lower portion of the structure, it is recommended that a hydraulic jump be forced by means of roughness elements placed along the bottom of the culvert. These roughness elements would be similar to those described in Section 9.03.3.3 for increased culvert resistance. However, the design guidance discussed in that section applies only to culverts on steep slopes and thus should not be used in the design of roughness elements for “broken-back” culverts. Rather, the following design guidelines should be sufficient to ensure that the hydraulic jump will occur as desired: First, the height of the roughness elements h , should be determined as:

$$h = 0.1 \times \frac{(B \times R)}{2(B + R)} \quad (6-17)$$

Where: h = height of the roughness elements, (ft)
 B = span of the box culvert, (ft)
 R = rise of the box culvert, (ft)

The distance between the elements, L, should be 10 times the height, h, and the roughness elements should be placed along the lowest 1/4th (one-fourth) of the total culvert length.

The Manning’s n-value and hydraulic performance for the roughened portion of the culvert are very difficult to assess. The guidance provided in the FHWA document *HEC-14* for n-values in roughened sections applies only to culverts on supercritical slopes and thus should not be applied to culverts on flat slopes. Although it may be possible that the increased roughness will result in a lower velocity at the culvert outfall, the velocity determined in Step 2 should be used for assessing culvert outflow conditions.

Step 5: Compare the costs of the “broken-back” and the straight culvert design options. The increased costs for excavation and construction for a “broken-back” alignment should be weighed against the cost savings achieved by the reduced need for an energy dissipator. In situations where the available right-of-way is very limited, a “broken-back” alignment may be the preferred option even if its cost is somewhat greater.

6.05.7 REVIEW RESULTS

Once a proposed culvert size has been determined, it should be reviewed to ensure that all of the applicable design criteria have been met. At a minimum, this will include the following:

- Ensure that the proposed barrel has adequate cover (see Section 6.04.2.3).
- Ensure that the culvert length used in the analysis matches the culvert length shown on the plans.
- Ensure that the allowable headwater elevation has not been exceeded (see Section 6.04.2.4.4).
- Ensure that the roadway serviceability criteria in Section 4.03.1 have been met.
- For culverts in inlet control, check whether an improved inlet would provide any economic benefit for the structure (see Section 6.04.3.2). Specific design procedures for improved inlets are provided in HDS-5.
- Determine the type of downstream channel lining or energy dissipation that will be required (see Section 9.01 of this Manual).

SECTION 6.06 – ACCEPTABLE SOFTWARE

The five microcomputer culvert design methods described in this section may be used for the hydraulic analysis and design of culverts (see Table 6-4). All of these methods are available as public domain software packages from various branches of the Federal government. This software should be used unless special circumstances on the project require other software. The TDOT Design Manager should approve the use of any other software for these special circumstances.

| Approved Software | Uses |
|-------------------------------|---|
| GEOPAK Drainage | Input directly from CADD computer files Culvert analysis with roadway overtopping Multiple barrels Wide variety of culvert types and alignments |
| HDS-5 | Culvert analysis without roadway overtopping |
| HY-8 | Culvert analysis for a range of discharges Roadway overtopping Improved inlet analysis Multiple barrels Energy dissipator design Automated function for culvert size selection Simple storage routing |
| HEC-RAS (Ver. 4.1.0 or later) | Culvert analysis with roadway overtopping Multiple Barrels Multiple opening analysis with bridges Complex storage routing |

Table 6-4
Acceptable Software Summary

The user is advised that no computer method is completely reliable, and the results from any of the software packages described below must always be carefully evaluated. A clear understanding of culvert hydraulics is therefore necessary to successfully apply any of these methods. Each of these methods provides default values for the hydraulic parameters needed to analyze flow through a culvert. The default Manning's n-values provided by the programs for various pipe materials may not agree with the criteria presented in Section 6.04.2. The designer should check the default Manning's n-values and adjust them as necessary.

6.06.1 GEOPAK DRAINAGE

GEOPAK Culvert is a module within GEOPAK Drainage that can be used for the design and analysis of culvert structures. The culvert tool is capable of collecting data from a variety of computer design files, including coordinate geometry databases, site database files, drainage database files or binary files. This enables the designer to utilize both existing and proposed roadway and/or storm sewer data.

GEOPAK Culvert has many features that allow for input flexibility, including, but not limited to:

- the ability to specify a range of discharges and corresponding tailwater depths for both design discharge and analysis
- definition of culvert properties including shape, material, size, number of barrels, roughness coefficients, and entrance type
- the ability to specify headwall locations
- the ability to specify the parameters used in the calculation of the overtopping flow

GEOPAK Culvert has the ability to analyze many different types of culvert shapes including round pipes, boxes, elliptical pipes, pipe arches and arch structures. Available materials include aluminum, concrete, steel and plastic. Further, the program includes a library of all manufactured pipe sizes. Finally, it is capable of estimating energy losses in curved pipe alignments.

GEOPAK Culvert also offers a number of “free design” options, including:

- minimum and maximum slope control
- minimum and maximum velocity control
- minimum and maximum size control
- upstream and downstream flow elevation control

GEOPAK Culvert computational features include tailwater and roadway overtopping calculations. It also has the ability to output to an ASCII file.

6.06.2 HDS-5, HYDRAULIC DESIGN OF HIGHWAY CULVERTS

The hand method for culvert design that is provided in HDS-5 (see Section 6.05) has been automated into a “smart” version of the culvert design worksheet. This worksheet is included with the F.H.W.A. publication of HDS-5 on CD ROM.

6.06.3 COMPUTER PROGRAM HY-8

HY-8 is a Windows™ based computer program developed by the FHWA. It automates the nomograph solutions for culvert design that are found in HDS-5. It also includes the following features:

- computes and provides a graph of the tailwater rating curve
- computes and provides a graph of the culvert performance curves
- provides a side view plot of the culvert showing the maximum computed water surface profile
- provides a front-view plot of the culvert as well as an option for a plan view based on a map downloaded from the Internet
- capable of analyzing both a design discharge and a check discharge
- includes analysis of circular and arch pipes, four-sided boxes and arch-boxes, elliptical pipes, long-span arches and allows for user input of custom shapes
- capable of analyzing improved end treatments, including side-tapered and slope-tapered improved inlets

- computes road overflow and is capable of analyzing installations of multiple identical barrels or of multiple barrels of differing shapes, sizes and elevations
- capable of energy dissipator design computations, using the methods prescribed in HEC-14
- output reports contain all of the computed results including the graphs and plots discussed above
- output reports can be generated in either Microsoft Word (.rtf) or Adobe Acrobat (.pdf) format

As of the date of this manual, the current version of HY-8 is 7.1 which is a complete update of the program to the Windows™ operating system. Documentation for the program is available from the FHWA Hydraulics internet web page.

6.06.4 COMPUTER PROGRAM HEC-RAS

HEC-RAS is a complete water surface profile computation package developed by the U.S. Army Corps of Engineers Hydraulic Engineering Center (HEC). In addition to culvert analysis, it is capable of water surface profile computations, bridge waterway analysis, analysis of branched networks of stream channels, and unsteady flow analysis, among many other things.

HEC-RAS will perform culvert analysis either by use of the nomographic data provided by HDS-5 or by computing a water surface profile through the culvert. Most of the culvert shapes available in HY-8 are also pre-programmed into HEC-RAS, along with data for a variety of inlet conditions. Because HEC-RAS is designed to perform large-scale water resources analyses, its input data requirements are considerably greater than those for HY-8. Although use of HEC-RAS involves considerably more effort than the use of HY-8, it would be an acceptable choice for extremely complicated situations which may be beyond the capabilities of GEOPAK or HY-8.

SECTION 6.07 – APPENDIX

6.07.1 FIGURES AND TABLE

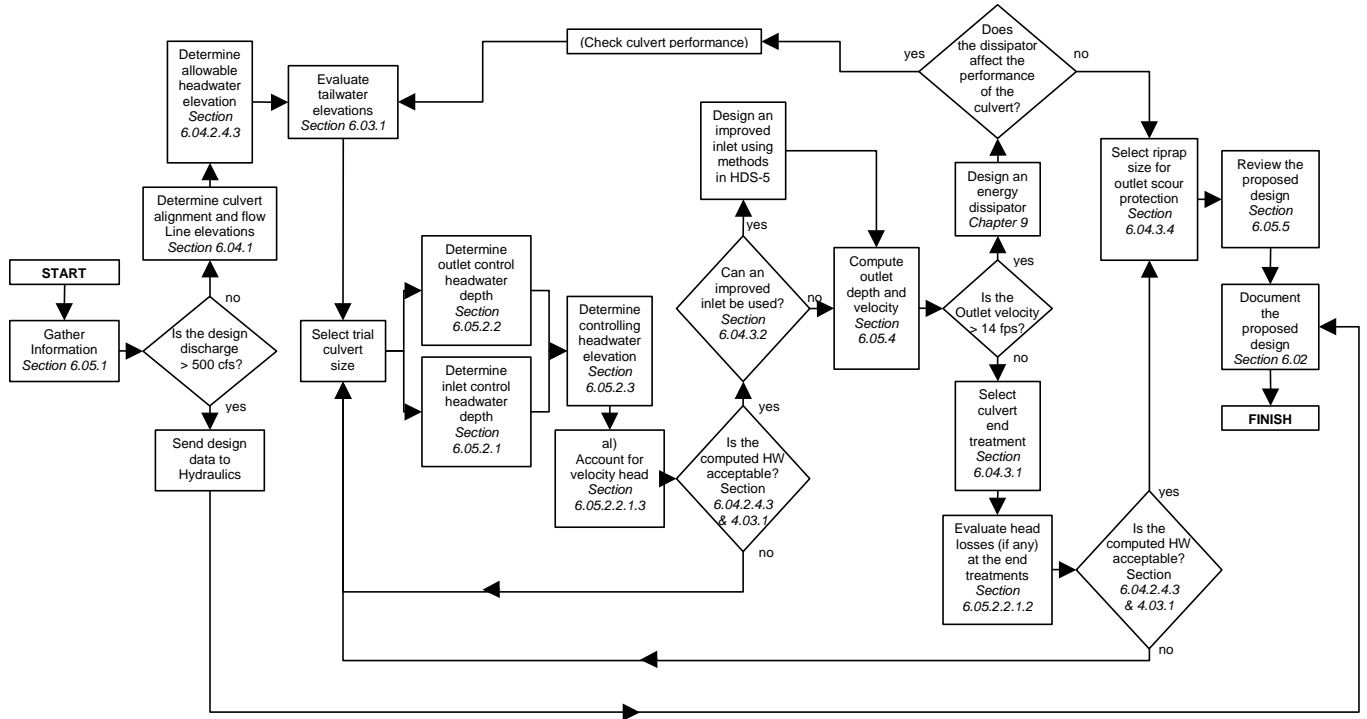

Figure 6A-1
Culvert Design Flow Chart

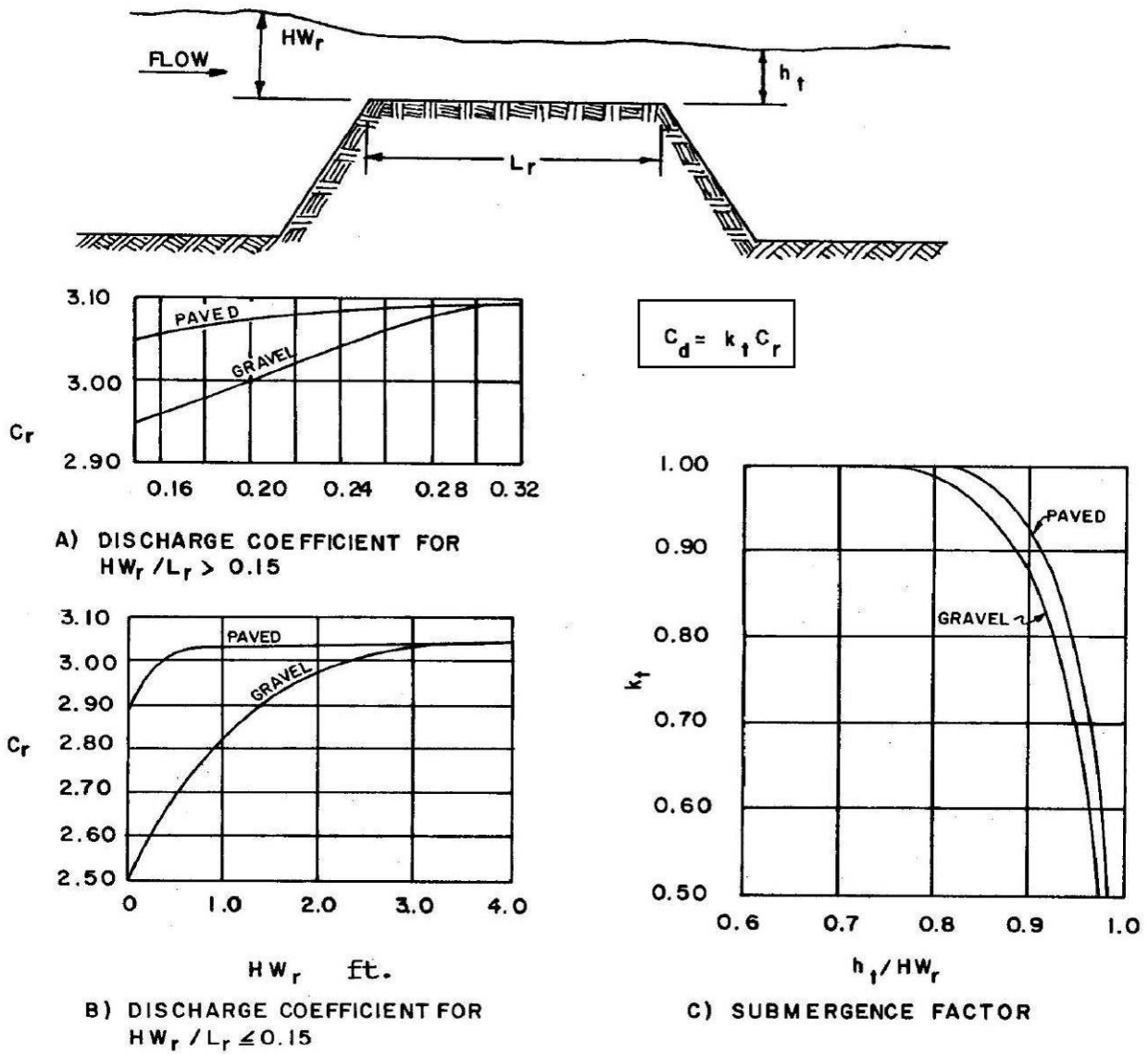

Figure 6A-3
 Discharge Coefficients for Roadway Overtopping
 Reference: USDOT, FHWA, HDS-5 (1985)

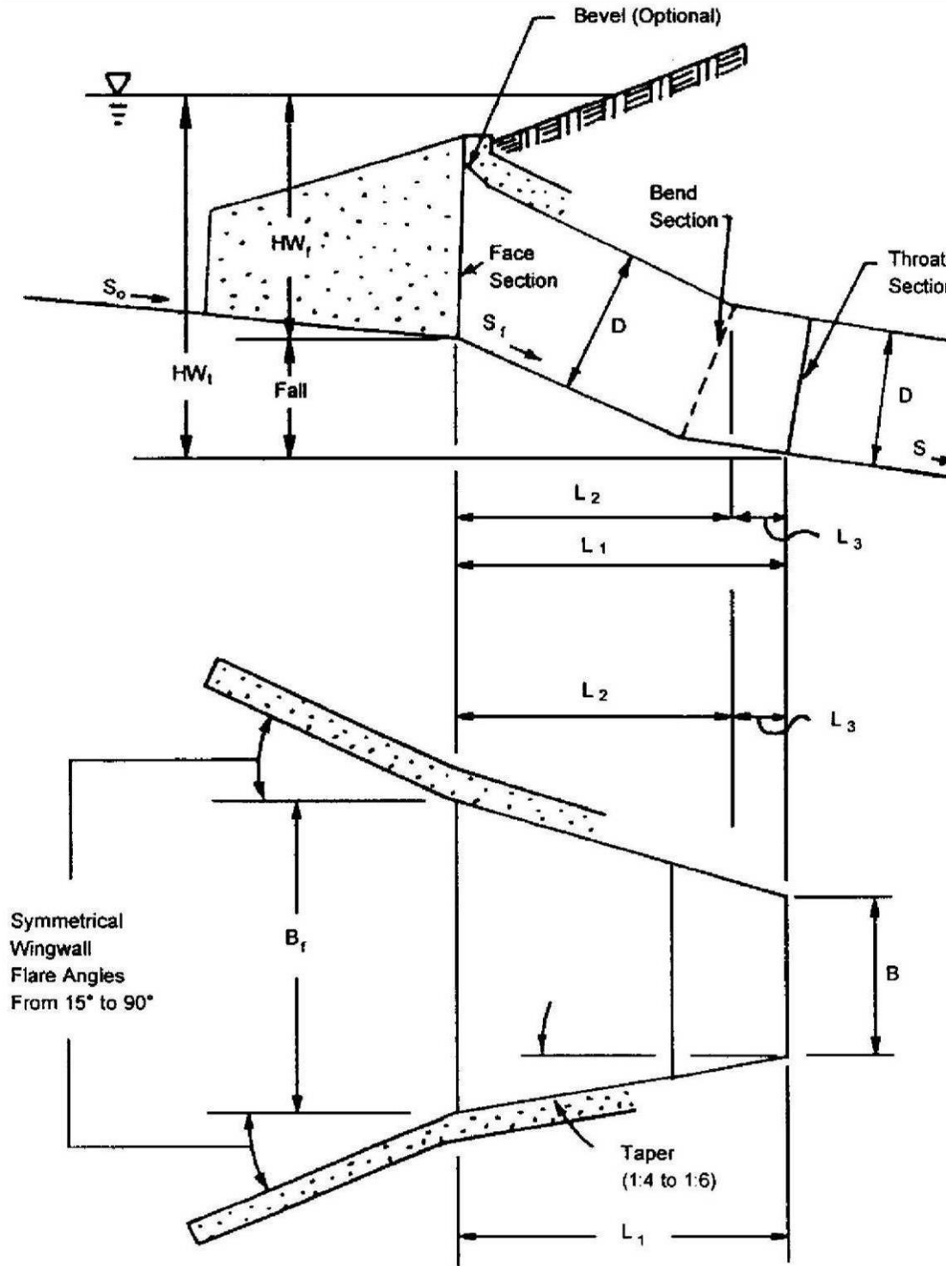

Figure 6A-4
 Slope Tapered Inlet with Vertical Face
 Reference: USDOT, FHWA, HDS-5 (1985)

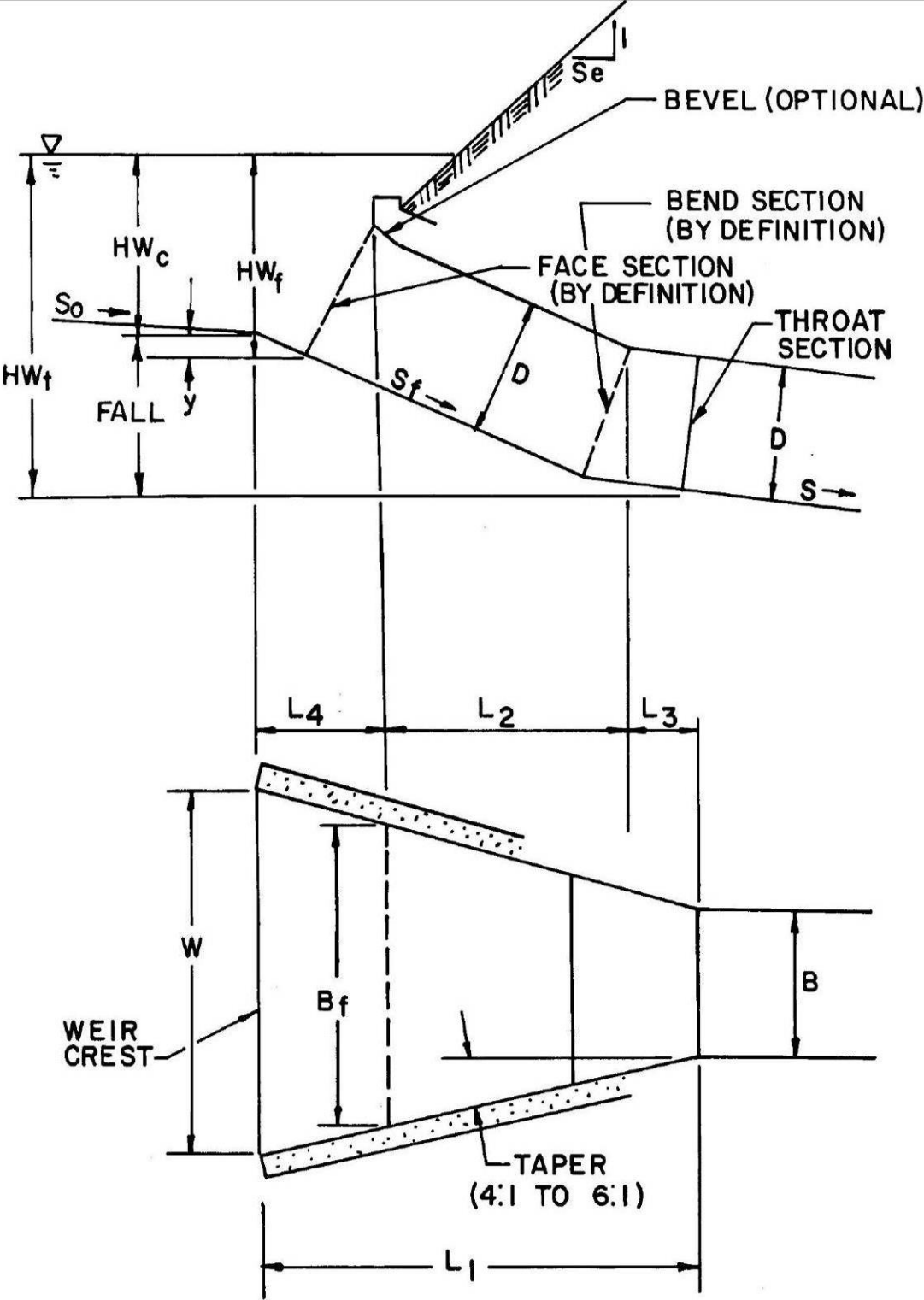

Figure 6A-5
Slope Inlet with Mitered Face
Reference: USDOT, FHWA, HDS-5 (1985)

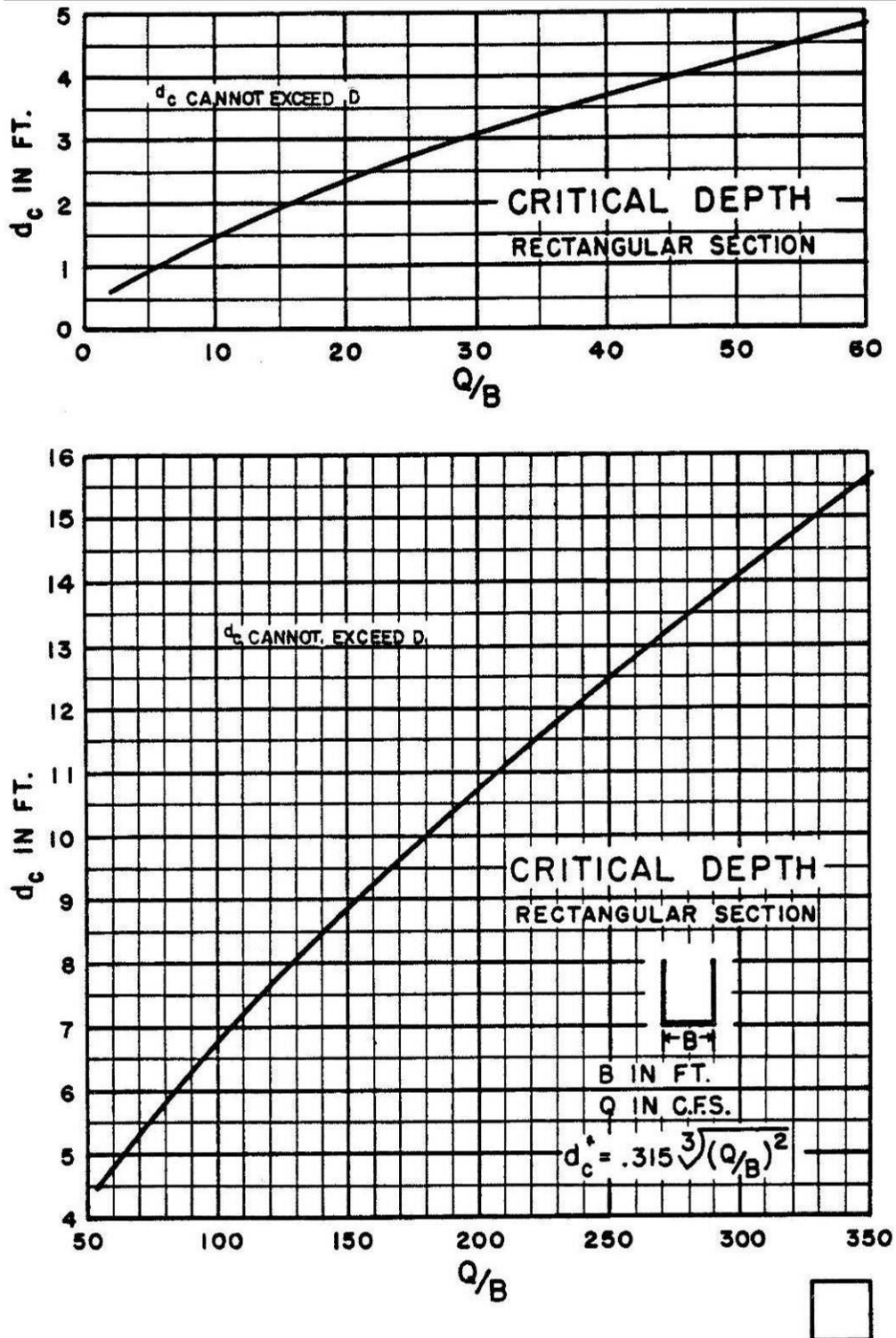

Figure 6A-6
 Critical Depth Chart for Rectangular Sections
 Reference: USDOT, FHWA, HDS-5 (1985)

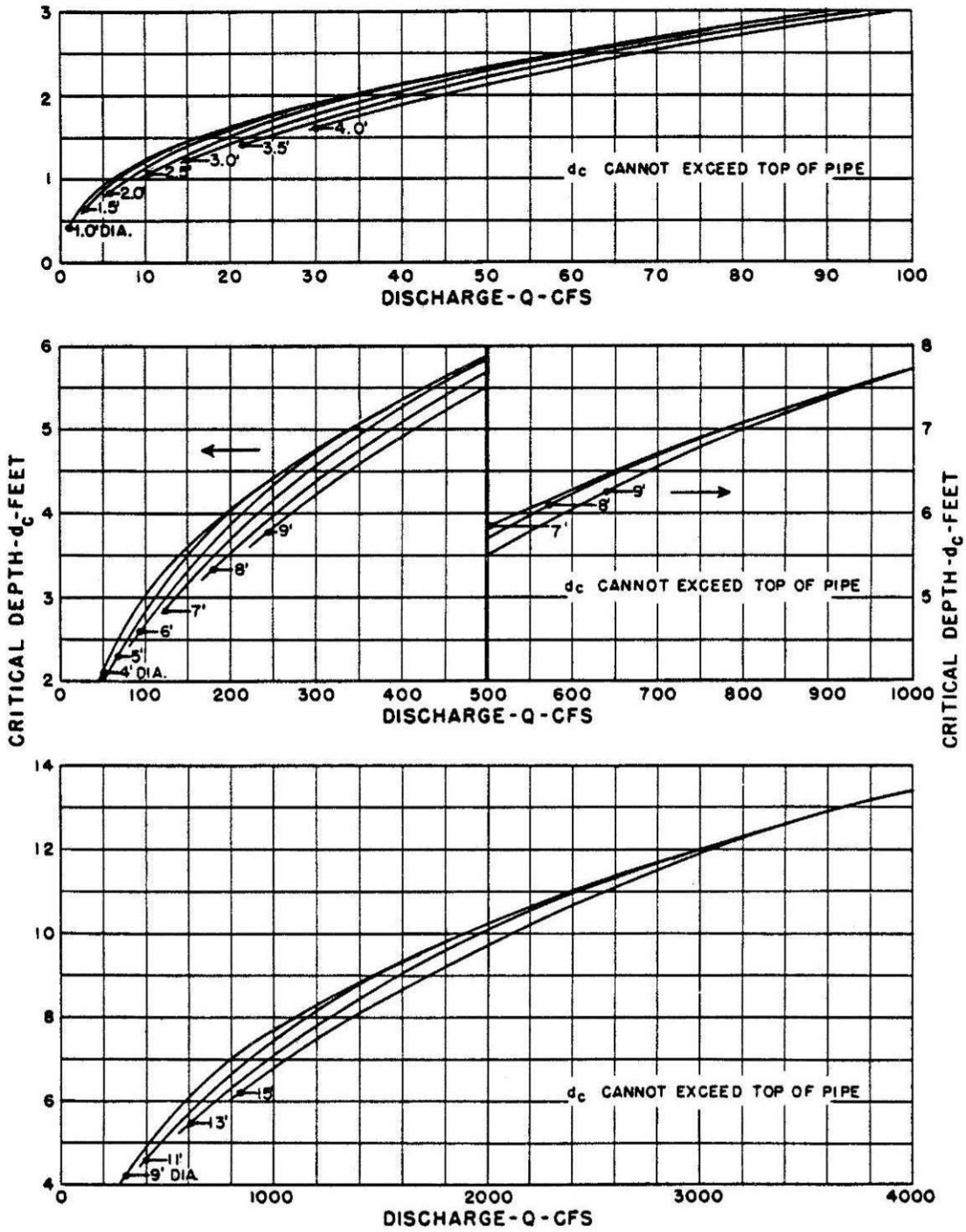

Figure 6A-7
 Critical Depth Chart for Circular Pipe
 Reference: USDOT, FHWA, HDS-5 (1985)

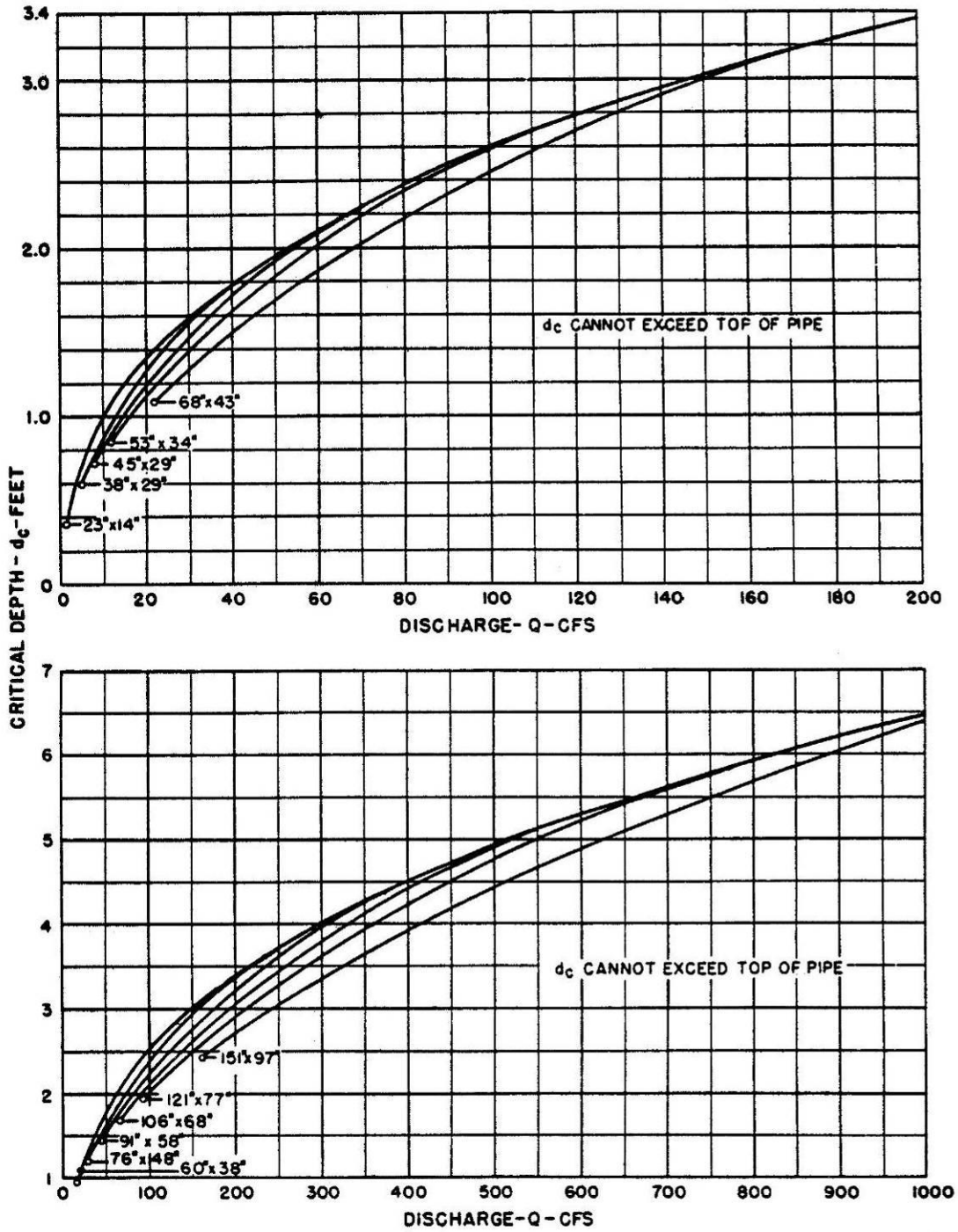

Figure 6A-8
 Critical Depth Chart for Oval Concrete Pipe – Long Axis Horizontal
 Reference: USDOT, FHWA, HDS-5 (1985)

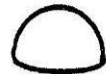
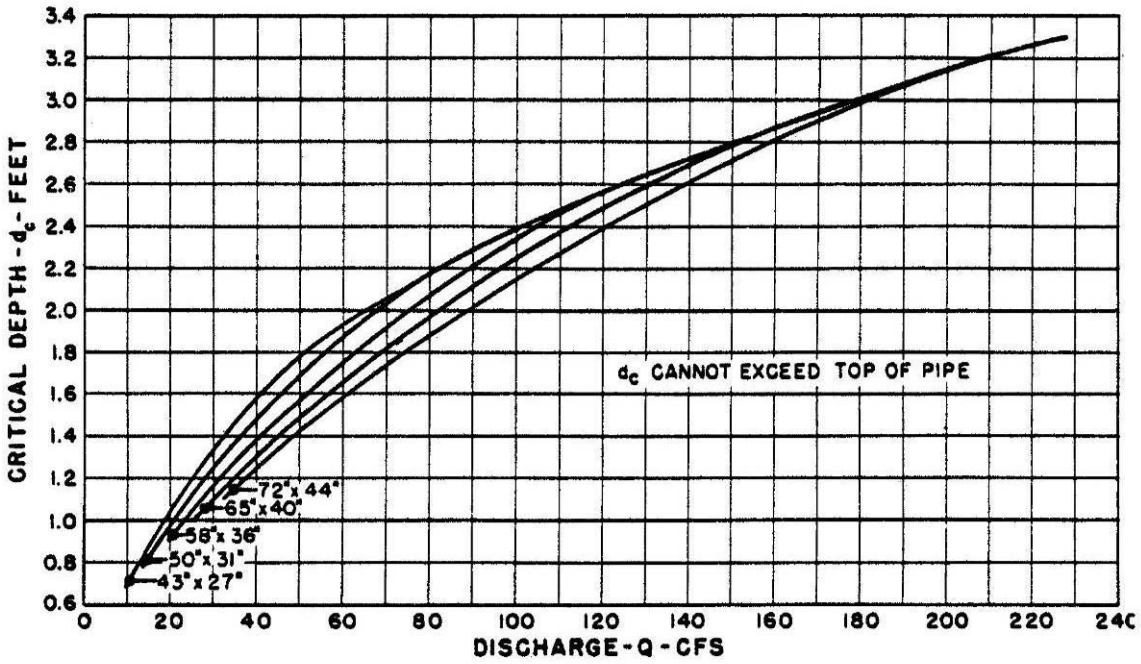
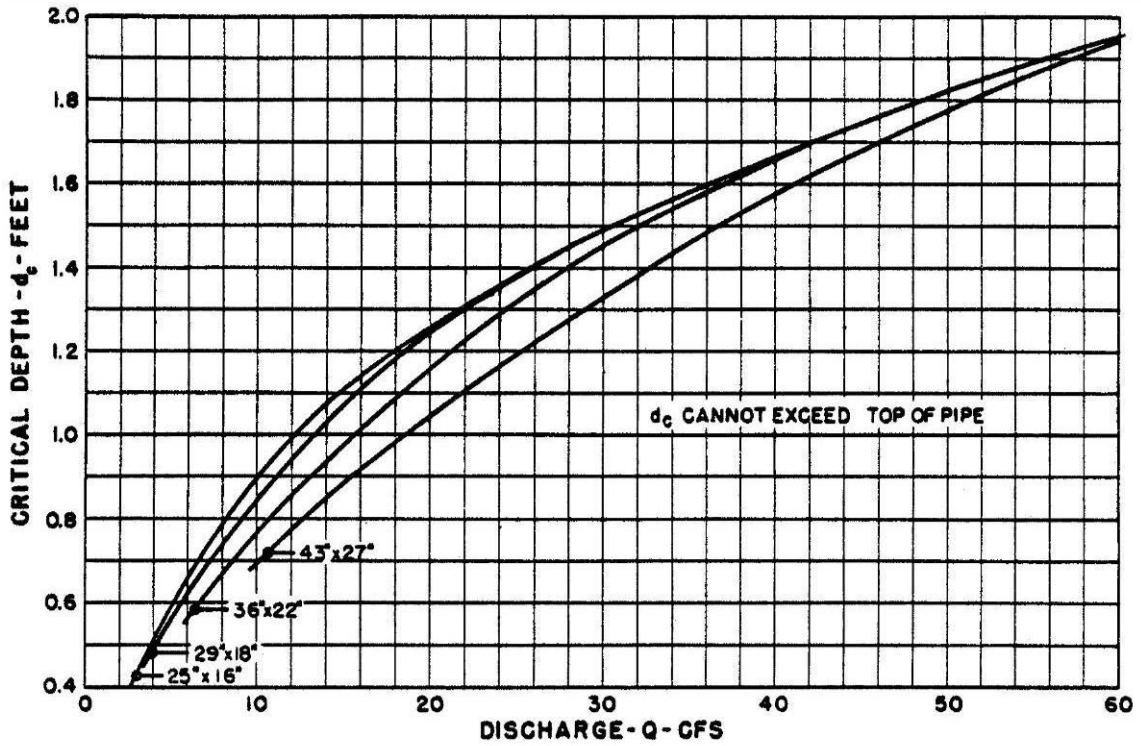

Figure 6A-9
 Critical Depth Chart for Standard CMP Arch
 Reference: USDOT, FHWA, HDS-5 (1985)

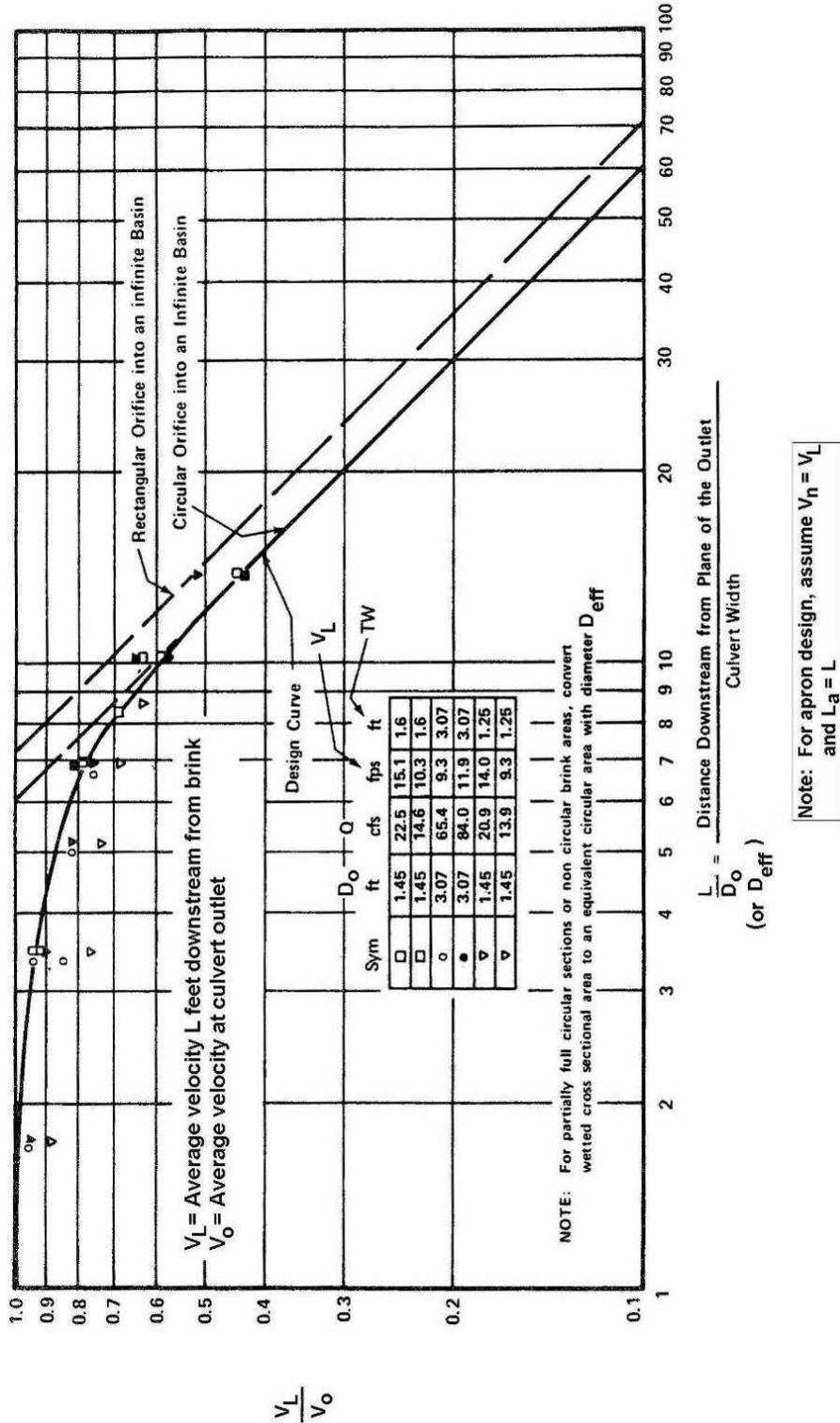

Figure 6A-10
 Distribution of Centerline Velocity for Flow from Submerged Outlets

| Fill Height (feet) | | | | | |
|---|---|---|------------------------------|----------------------|---------------|
| | ≤ 10 ft | > 10 ft and ≤ 16 ft | > 16 ft and ≤ 24 ft | > 24 ft and ≤ 38 ft | > 38 ft |
| Interstate system and any arterial with full access control (Freeways) | | | | | |
| Cross drains, Transverse median drains & Longitudinal storm drains | RCP CL III | RCP CL III | RCP CL IV | RCP CL V | <i>note 1</i> |
| Arterials | | | | | |
| Cross drains & Transverse median drains | RCP CL III CMP 10 g PVC HDPE / PP | RCP CL III CMP 10 g PVC HDPE | RCP CL IV PVC | RCP CL V | <i>note 1</i> |
| Longitudinal storm drains | RCP CL III PVC HDPE / PP | RCP CL III PVC HDPE | RCP CL IV PVC | RCP CL V | <i>note 1</i> |
| Collectors | | | | | |
| Cross drains & Transverse median drains | RCP CL III CMP 12 g PVC SRTRP HDPE / PP | RCP CL III CMP 12 g PVC SRTRP HDPE / PP | RCP CL IV CMP 12 g PVC | RCP CL V CMP 12 g | <i>note 1</i> |
| Longitudinal storm drains | RCP CL III PVC HDPE / PP | RCP CL III PVC HDPE / PP | RCP CL IV PVC | RCP CL V | <i>note 1</i> |
| Local Roads | | | | | |
| Cross drains | RCP CL III CMP 14 g PVC SRTRP HDPE / PP | RCP CL III CMP 14 g PVC SRTRP HDPE / PP | RCP CL IV CMP 14 g PVC | RCP CL V CMP 14 g | <i>note 1</i> |
| Longitudinal Storm Drains | RCP CL III PVC SRTRP HDPE / PP | RCP CL III PVC SRTRP HDPE / PP | RCP CL IV PVC | RCP CL V | <i>note 1</i> |
| For All Road Systems | | | | | |
| Side Drains (Pipes under private drives, business or field entrances) | RCP CL III CMP 16 g PVC SRTRP HDPE / PP | RCP CL III CMP 14 g PVC SRTRP HDPE / PP | RCP CL IV CMP 14 g PVC | RCP CL V CMP 14 g | <i>note 1</i> |
| Longitudinal Median Drains | RCP CL III CMP 16 g PVC SRTRP HDPE / PP | RCP CL III PVC SRTRP HDPE / PP | RCP CL IV PVC | RCP CL V | <i>note 1</i> |

Table 6A-1
Pipe Selection Criteria Based on System and Fill Height
(see notes on next page)

Note 1: Only RCP CL V is allowed with fill heights for pipes over 38 feet. RCP shall be a minimum of 42" for future maintenance inspection activities. Special installation detail may be required.

RCP: RCP wall thickness shall be type "B" as shown in AASHTO Designation M-170.

CMP: All CMP shall be aluminized coated meeting AASHTO M-274. Unless otherwise stated on Table 6A-1. for pipes \geq 54 inches use 10-gage CMP, except on local roads.

HDPE: HDPE pipe shall meet AASHTO designation M-294-02. The maximum pipe diameter for HDPE pipe is 60 inches. The minimum cover shall be in accordance to the minimum cover depths shown on standard drawing D-PB-3 for construction loads.

PVC: PVC (Poly Vinyl Chloride) Profile Wall drainage pipe shall meet AASHTO Designation M-304(2007). The maximum pipe diameter for PVC pipe is 36 inches.

SRTRP: SRTRP shall meet AASHTO Designation MP-20. The maximum pipe diameter for SRTRP is 60".

PP: Shall meet the requirements of AASHTO Designation M330. The maximum pipe diameter for PP is 60".

- RCP = Reinforced Concrete Pipe
- CMP = Corrugated Metal Pipe
- HDPE = High Density Polyethylene
- PVC = PolyVinyl Chloride
- SRTRP = Steel Reinforced Thermoplastic Ribbed Pipe
- PP = Polypropylene Pipe

Table 6A-1 (continued)
Notes for Pipe Selection Criteria Based on System and Fill Height

| CROSS DRAIN TABULATION | | | | | | | | | | | | | | | | | | | |
|------------------------|---|--|--|-----------|-------------|--|-------------|----------|-------------|----------|-----------|-------------------------------|---------------|----------------------|-------------|----------------------|-------------|------------|--|
| STATION | RCP CLASS III OR CMP 10 GA. OR HDPE OR PP OR PVC OR SRTRP (L.F.) FILL HEIGHT < OR = 16 FT. | | | | | RCP CLASS IV OR PVC OR PP (L.F.) FILL HEIGHT > 16 FT. AND < OR = 24 FT. | | | | | SKEW | RIP-RAP 709-05.06 (TON) | END TREATMENT | | | | REMARKS | | |
| | 18" | 24" | 30" | 36" | 48" | 18" | 24" | 30" | 36" | 48" | | | INLET | | OUTLET | | | | |
| | CLASS A CONC. 611-07.01 (C.Y.) | REINF. STEEL 611-07.02 (L.B.) | STRUC. STEEL 611-07.03 (L.B.) | TYPE | DRAWING NO. | TYPE | DRAWING NO. | TYPE | DRAWING NO. | TYPE | | | DRAWING NO. | TYPE | DRAWING NO. | | | | |
| 632+43 | 45 | | | | | | | | | | 90 | 6 | 4:1 "U" | D-PE-18A D-PE-18B | 4:1 "U" | D-PE-18A D-PE-18B | 196 | | |
| 688+90 | | 50 | | | | | | | | | 78 | 12 | 6:1 "U" | D-PE-24A D-PE-24B | 6:1 "U" | D-PE-24A D-PE-24B | 606 | 372 | |
| 691+50 | | | | | | 65 | | | | | 90 | 0 | 6:1 "U" | D-PE-24A D-PE-24B | 6:1 "U" | D-PE-24A D-PE-24B | 430 | | |
| 761+22 | | | | 40 | | | | | | | 90 | 17 | 4:1 "U" | D-PE-36A D-PE-36B | 4:1 "U" | D-PE-36A D-PE-36B | 552 | 320 | |
| TOTALS | 45 | 50 | 0 | 40 | 0 | 65 | 0 | 0 | 0 | 0 | 35 | | | | | | 1784 | 692 | |

Table 6A-3
Typical Cross Drain Tabulation for Arterials without Full Access Control

| CROSS DRAIN TABULATION | | | | | | | | | | | | | | | | | | | | |
|------------------------|--|-----------|----------|-----------|--|----------|----------|----------|----------|-------------------------------|-------|----------------------|-------------|----------------------|---|--|--|---------|-------------|------|
| STATION | RCP CLASS III OR CMP 14 GA. OR PP OR HDPE OR PVC, OR SRTRP (L.F.) FILL HEIGHT < OR = 16 FT. | | | | RCP CLASS IV OR CMP 14 GA. OR PP OR PVC (L.F.) FILL HEIGHT > 16 FT. AND < OR = 24 FT. | | | | SKEW | RIP-RAP 709-05.06 (TON) | INLET | | OUTLET | | CLASS A CONC. 611-07.01 (C.Y.) | REINF. STEEL 611-07.02 (L.B.) | STRUC. STEEL 611-07.03 (L.B.) | REMARKS | | |
| | 18" | 24" | 30" | 36" | 48" | 18" | 24" | 30" | | | 36" | 48" | DRAWING NO. | TYPE | | | | | DRAWING NO. | TYPE |
| | | | | | | | | | | | | | | | | | | | | |
| 632+43 | | | | | 48" | | | | | 90 | 6 | D-PE-18A D-PE-18B | 4:1 "U" | D-PE-18A D-PE-18B | 2.16 | 196 | | | | |
| 688+90 | | 50 | | | | | | | | 78 | 12 | D-PE-24A D-PE-24B | 6:1 "U" | D-PE-24A D-PE-24B | 6.58 | 606 | 372 | | | |
| 691+50 | | | | | | 65 | | | | 90 | 0 | D-PE-24A D-PE-24B | 6:1 "U" | D-PE-24A D-PE-24B | 4.52 | 430 | | | | |
| 761+22 | | | | 40 | | | | | | 90 | 17 | D-PE-36A D-PE-36B | 4:1 "U" | D-PE-36A D-PE-36B | 6.16 | 552 | 320 | | | |
| TOTALS | 45 | 50 | 0 | 40 | 0 | 0 | 0 | 0 | 0 | 35 | | | | | 19.42 | 1784 | 692 | | | |

Table 6A-4
Typical Cross Drain Tabulation for Local Roads

| CROSS DRAIN TABULATION | | | | | | | | | | | | | | | | | | |
|------------------------|----------|----|-------------|----------------------|---|-----|-----|-----|---|-----|-----|-----|---------------|-----|-------|---------|----------------------|---------------------|
| STATION | LOCATION | | DESCRIPTION | SURFACE WIDTH (L.F.) | RCP CLASS III OR CMP 16 GA. OR HDPE OR PVC, OR PP OR SRTRP (L.F.) FILL HEIGHT < OR = 10 FT. | | | | RCP CLASS IV OR, SRTRP OR CMP 14 GA. OR PP OR PVC (L.F.) FILL HEIGHT > 10 FT. AND < OR = 16 FT. | | | | END TREATMENT | | | REMARKS | | |
| | LT | RT | | | 18" | 24" | 30" | 36" | 48" | 18" | 24" | 30" | 36" | 48" | INLET | | CLASS A CONC. (C.Y.) | REINF. STEEL (L.B.) |
| 632+43 | X | | PVT DRIVE | 12 | | | | | | | | | | | | | | |
| 688+90 | | X | PVT DRIVE | 12 | 24 | | | | | | | | | | 606 | 372 | | |
| 691+50 | X | | PVT DRIVE | 10 | 22 | | | | | | | | | | 430 | | | |
| 761+22 | X | | PVT DRIVE | 14 | | | 24 | | | | | | | | 552 | 320 | | |
| TOTALS | | | | | 20 | 46 | 0 | 24 | 0 | 0 | 0 | 0 | 0 | 0 | 19.42 | 1784 | 692 | |

Table 6A-5
Typical Side Drain Tabulation

| Type of Structure and End Treatment | K_e |
|---|-------|
| Concrete Pipes | |
| “Bell” (groove end) projecting from fill | 0.2 |
| Square-cut end, projecting from fill | 0.5 |
| Headwall or headwall with wingwalls | |
| “Bell” (groove end) of pipe in wall | 0.2 |
| Square edge | 0.5 |
| Rounded (radius = diameter / 12) | 0.2 |
| Mitered to conform to fill slope ^a | 0.7 |
| Fabricated mitered end-section conforming to fill slope | 0.5 |
| Beveled edges, 33.7° or 45° bevels | 0.2 |
| Side- or slope-tapered inlet | 0.2 |
| Corrugated Metal Pipes or Pipe-Arches | |
| Project from fill slope (no headwall) | 0.9 |
| Square edge in headwall or headwall with wingwalls | 0.5 |
| Mitered to conform to fill slope | 0.7 |
| Fabricated mitered end section conforming to fill slope | 0.5 |
| Beveled edges, 33.7° or 45° bevels | 0.2 |
| Side- or slope-tapered inlet | 0.2 |
| High-Density Polyethylene Pipes / Polyvinyl Chloride | |
| Square edge in headwall or headwall with wingwalls | 0.5 |
| Beveled edges, 33.7° or 45° bevels | 0.2 |
| Side- or slope-tapered inlet | 0.2 |
| Reinforced Concrete Boxes | |
| Headwall parallel to embankment (no wingwalls) | |
| Square edge | 0.5 |
| Rounded (radius = Rise / 12) or beveled on three sides | 0.2 |
| Wingwalls at angles from 30° to 75° from the barrel | |
| Square edge at top | 0.4 |
| Rounded (radius = Rise / 12) or beveled at top | 0.2 |
| Wingwalls at angles from 10° to 25° from the barrel, square edge at top | 0.5 |
| Wingwalls parallel (extension of sides), square edge at top | 0.7 |
| Side-tapered or slope-tapered inlet | 0.2 |

^a End sections made of either concrete or metal are sections commonly available from manufacturers. From limited hydraulic tests, the sections are approximately equal in operation to a headwall in both inlet and outlet control. Closed-tapered end sections have a superior hydraulic performance.

Table 6A-6
 Entrance Loss Coefficients K_e
 for Culverts in Outlet Control
 Reference: USDOT, FHWA, HDS-5 (1985)
 Adapted for HDPE Pipe (TDOT, 2007)

| Q (cfs) | Diameter in inches | | | | | | | | | | | | | |
|------------|--------------------|------|------|------|------|------|------|------|------|------|------|------|------|--|
| | 15 | 18 | 24 | 30 | 36 | 42 | 48 | 54 | 60 | 72 | 84 | 96 | | |
| 0.1 | 0.12 | 0.12 | 0.11 | 0.10 | 0.10 | 0.09 | 0.09 | 0.09 | 0.09 | 0.09 | 0.08 | 0.08 | 0.08 | |
| 0.3 | 0.21 | 0.20 | 0.19 | 0.18 | 0.17 | 0.16 | 0.16 | 0.15 | 0.15 | 0.15 | 0.14 | 0.14 | 0.13 | |
| 0.6 | 0.30 | 0.29 | 0.27 | 0.25 | 0.24 | 0.23 | 0.22 | 0.22 | 0.21 | 0.21 | 0.20 | 0.19 | 0.19 | |
| 1 | 0.39 | 0.37 | 0.34 | 0.32 | 0.31 | 0.30 | 0.29 | 0.28 | 0.27 | 0.27 | 0.26 | 0.25 | 0.24 | |
| 1.5 | 0.48 | 0.46 | 0.42 | 0.40 | 0.38 | 0.36 | 0.35 | 0.34 | 0.33 | 0.33 | 0.32 | 0.30 | 0.29 | |
| 2 | 0.56 | 0.53 | 0.49 | 0.46 | 0.44 | 0.42 | 0.41 | 0.39 | 0.38 | 0.38 | 0.37 | 0.35 | 0.34 | |
| 3 | 0.70 | 0.66 | 0.60 | 0.57 | 0.54 | 0.52 | 0.50 | 0.48 | 0.47 | 0.47 | 0.45 | 0.43 | 0.42 | |
| 4 | 0.81 | 0.77 | 0.70 | 0.66 | 0.62 | 0.60 | 0.58 | 0.56 | 0.54 | 0.54 | 0.52 | 0.50 | 0.48 | |
| 5 | 0.91 | 0.86 | 0.79 | 0.74 | 0.70 | 0.67 | 0.65 | 0.63 | 0.61 | 0.61 | 0.58 | 0.56 | 0.54 | |
| 7 | 1.06 | 1.02 | 0.94 | 0.88 | 0.83 | 0.80 | 0.77 | 0.74 | 0.72 | 0.72 | 0.69 | 0.66 | 0.64 | |
| 9 | 1.16 | 1.16 | 1.07 | 1.00 | 0.95 | 0.91 | 0.87 | 0.84 | 0.82 | 0.82 | 0.78 | 0.75 | 0.72 | |
| 11 | 1.20 | 1.27 | 1.19 | 1.11 | 1.05 | 1.00 | 0.97 | 0.94 | 0.91 | 0.91 | 0.87 | 0.83 | 0.80 | |
| 15 | 1.24 | 1.41 | 1.40 | 1.31 | 1.23 | 1.18 | 1.13 | 1.10 | 1.07 | 1.07 | 1.01 | 0.97 | 0.94 | |
| 20 | 1.25 | 1.47 | 1.61 | 1.52 | 1.43 | 1.37 | 1.32 | 1.27 | 1.23 | 1.23 | 1.17 | 1.12 | 1.08 | |
| 25 | 1.25 | 1.49 | 1.76 | 1.70 | 1.61 | 1.54 | 1.48 | 1.43 | 1.38 | 1.38 | 1.31 | 1.26 | 1.21 | |
| 30 | 1.25 | 1.50 | 1.86 | 1.87 | 1.77 | 1.69 | 1.62 | 1.57 | 1.52 | 1.52 | 1.44 | 1.38 | 1.33 | |
| 40 | 1.25 | 1.50 | 1.95 | 2.13 | 2.06 | 1.97 | 1.89 | 1.82 | 1.76 | 1.76 | 1.67 | 1.60 | 1.54 | |
| 50 | 1.25 | 1.50 | 1.98 | 2.30 | 2.30 | 2.21 | 2.12 | 2.05 | 1.98 | 1.98 | 1.88 | 1.80 | 1.73 | |
| 60 | 1.25 | 1.50 | 2.00 | 2.39 | 2.50 | 2.43 | 2.33 | 2.25 | 2.18 | 2.18 | 2.06 | 1.97 | 1.90 | |
| 75 | 1.25 | 1.50 | 2.00 | 2.45 | 2.72 | 2.71 | 2.62 | 2.53 | 2.45 | 2.45 | 2.32 | 2.21 | 2.13 | |
| 90 | 1.25 | 1.50 | 2.00 | 2.48 | 2.85 | 2.94 | 2.88 | 2.78 | 2.69 | 2.69 | 2.55 | 2.43 | 2.34 | |
| 115 | 1.25 | 1.50 | 2.00 | 2.50 | 2.94 | 3.21 | 3.24 | 3.16 | 3.06 | 3.06 | 2.89 | 2.76 | 2.65 | |
| 150 | 1.25 | 1.50 | 2.00 | 2.50 | 2.98 | 3.39 | 3.60 | 3.59 | 3.51 | 3.51 | 3.33 | 3.17 | 3.05 | |
| 200 | 1.25 | 1.50 | 2.00 | 2.50 | 3.00 | 3.46 | 3.85 | 4.04 | 4.04 | 4.04 | 3.87 | 3.69 | 3.54 | |
| 250 | 1.25 | 1.50 | 2.00 | 2.50 | 3.00 | 3.50 | 3.93 | 4.28 | 4.42 | 4.42 | 4.33 | 4.14 | 3.98 | |
| 300 | 1.25 | 1.50 | 2.00 | 2.50 | 3.00 | 3.50 | 3.97 | 4.39 | 4.67 | 4.67 | 4.73 | 4.56 | 4.38 | |
| 350 | 1.25 | 1.50 | 2.00 | 2.50 | 3.00 | 3.50 | 4.00 | 4.44 | 4.81 | 4.81 | 5.07 | 4.93 | 4.74 | |
| 400 | 1.25 | 1.50 | 2.00 | 2.50 | 3.00 | 3.50 | 4.00 | 4.46 | 4.89 | 4.89 | 5.33 | 5.27 | 5.08 | |
| 500 | 1.25 | 1.50 | 2.00 | 2.50 | 3.00 | 3.50 | 4.00 | 4.50 | 4.95 | 4.95 | 5.67 | 5.84 | 5.70 | |

Table 6A-7
 Critical Depth in Feet for Circular Culverts
 (Critical depth cannot be greater than culvert diameter)

| Q (cfs) | Nominal Dimensions in inches | | | | | | | | | | | | | | |
|------------|------------------------------|-------|-------|-------|-------|-------|-------|-------|-------|-------|-------|-------|--|--|--|
| | 23x14 | 30x19 | 34x22 | 38x24 | 42x27 | 45x29 | 49x32 | 53x34 | 60x38 | 68x43 | 48x76 | 83x53 | | | |
| 0.1 | 0.10 | 0.09 | 0.09 | 0.09 | 0.09 | 0.08 | 0.08 | 0.08 | 0.08 | 0.08 | 0.08 | 0.08 | | | |
| 0.3 | 0.17 | 0.16 | 0.16 | 0.15 | 0.15 | 0.15 | 0.14 | 0.14 | 0.14 | 0.14 | 0.13 | 0.12 | | | |
| 0.6 | 0.24 | 0.23 | 0.22 | 0.21 | 0.21 | 0.20 | 0.20 | 0.20 | 0.19 | 0.18 | 0.18 | 0.18 | | | |
| 1 | 0.31 | 0.29 | 0.28 | 0.27 | 0.27 | 0.26 | 0.26 | 0.25 | 0.24 | 0.24 | 0.24 | 0.23 | | | |
| 1.5 | 0.38 | 0.36 | 0.35 | 0.34 | 0.33 | 0.32 | 0.32 | 0.31 | 0.30 | 0.29 | 0.40 | 0.28 | | | |
| 2 | 0.44 | 0.42 | 0.40 | 0.39 | 0.38 | 0.37 | 0.37 | 0.36 | 0.35 | 0.33 | 0.46 | 0.32 | | | |
| 3 | 0.55 | 0.51 | 0.50 | 0.48 | 0.47 | 0.46 | 0.45 | 0.44 | 0.42 | 0.41 | 0.56 | 0.39 | | | |
| 4 | 0.64 | 0.59 | 0.58 | 0.55 | 0.54 | 0.53 | 0.52 | 0.51 | 0.49 | 0.47 | 0.65 | 0.45 | | | |
| 5 | 0.72 | 0.67 | 0.65 | 0.62 | 0.61 | 0.60 | 0.58 | 0.57 | 0.55 | 0.53 | 0.73 | 0.51 | | | |
| 7 | 0.85 | 0.80 | 0.77 | 0.74 | 0.72 | 0.71 | 0.69 | 0.68 | 0.65 | 0.63 | 0.86 | 0.60 | | | |
| 9 | 0.96 | 0.91 | 0.88 | 0.84 | 0.82 | 0.81 | 0.79 | 0.77 | 0.74 | 0.71 | 0.98 | 0.68 | | | |
| 11 | 1.04 | 1.01 | 0.97 | 0.94 | 0.91 | 0.89 | 0.87 | 0.85 | 0.82 | 0.79 | 1.08 | 0.75 | | | |
| 15 | 1.14 | 1.18 | 1.14 | 1.10 | 1.07 | 1.05 | 1.03 | 1.00 | 0.96 | 0.93 | 1.27 | 0.88 | | | |
| 20 | 1.17 | 1.34 | 1.33 | 1.28 | 1.25 | 1.22 | 1.19 | 1.16 | 1.11 | 1.07 | 1.47 | 1.02 | | | |
| 25 | 1.17 | 1.45 | 1.48 | 1.43 | 1.40 | 1.37 | 1.34 | 1.30 | 1.25 | 1.21 | 1.64 | 1.14 | | | |
| 30 | 1.17 | 1.53 | 1.59 | 1.57 | 1.54 | 1.51 | 1.47 | 1.43 | 1.38 | 1.32 | 1.80 | 1.25 | | | |
| 40 | 1.17 | 1.58 | 1.74 | 1.77 | 1.77 | 1.75 | 1.71 | 1.67 | 1.60 | 1.54 | 2.09 | 1.45 | | | |
| 50 | 1.17 | 1.58 | 1.83 | 1.89 | 1.95 | 1.95 | 1.92 | 1.87 | 1.80 | 1.73 | 2.35 | 1.63 | | | |
| 60 | 1.17 | 1.58 | 1.83 | 2.00 | 2.07 | 2.10 | 2.10 | 2.05 | 1.98 | 1.90 | 2.58 | 1.79 | | | |
| 75 | 1.17 | 1.58 | 1.83 | 2.00 | 2.21 | 2.25 | 2.31 | 2.28 | 2.22 | 2.14 | 2.90 | 2.01 | | | |
| 90 | 1.17 | 1.58 | 1.83 | 2.00 | 2.25 | 2.37 | 2.45 | 2.47 | 2.43 | 2.35 | 3.19 | 2.21 | | | |
| 115 | 1.17 | 1.58 | 1.83 | 2.00 | 2.25 | 2.42 | 2.63 | 2.66 | 2.71 | 2.66 | 3.62 | 2.52 | | | |
| 150 | 1.17 | 1.58 | 1.83 | 2.00 | 2.25 | 2.42 | 2.67 | 2.83 | 2.95 | 3.01 | 4.16 | 2.89 | | | |
| 200 | 1.17 | 1.58 | 1.83 | 2.00 | 2.25 | 2.42 | 2.67 | 2.83 | 3.17 | 3.32 | 4.81 | 3.34 | | | |
| 250 | 1.17 | 1.58 | 1.83 | 2.00 | 2.25 | 2.42 | 2.67 | 2.83 | 3.17 | 3.54 | 5.33 | 3.70 | | | |
| 300 | 1.17 | 1.58 | 1.83 | 2.00 | 2.25 | 2.42 | 2.67 | 2.83 | 3.17 | 3.58 | 5.70 | 3.97 | | | |
| 350 | 1.17 | 1.58 | 1.83 | 2.00 | 2.25 | 2.42 | 2.67 | 2.83 | 3.17 | 3.58 | 5.95 | 4.14 | | | |
| 400 | 1.17 | 1.58 | 1.83 | 2.00 | 2.25 | 2.42 | 2.67 | 2.83 | 3.17 | 3.58 | 6.18 | 4.30 | | | |
| 500 | 1.17 | 1.58 | 1.83 | 2.00 | 2.25 | 2.42 | 2.67 | 2.83 | 3.17 | 3.58 | 6.33 | 4.42 | | | |

Table 6A-8
 Critical Depth in Feet for Horizontal Elliptical Culverts
 (Critical depth cannot be greater than culvert rise)

| Q (cfs) | Nominal Dimensions in inches | | | | | | | | | | | |
|------------|------------------------------|-------|-------|-------|-------|-------|-------|-------|-------|-------|-------|-------|
| | 17x13 | 21x15 | 24x18 | 28x20 | 35x24 | 42x29 | 49x33 | 57x38 | 64x43 | 71x47 | 77x52 | 83x57 |
| 0.1 | 0.09 | 0.09 | 0.09 | 0.09 | 0.09 | 0.08 | 0.08 | 0.08 | 0.07 | 0.06 | 0.06 | 0.05 |
| 0.3 | 0.16 | 0.15 | 0.15 | 0.14 | 0.14 | 0.13 | 0.13 | 0.13 | 0.14 | 0.13 | 0.13 | 0.11 |
| 0.6 | 0.23 | 0.21 | 0.21 | 0.20 | 0.19 | 0.19 | 0.18 | 0.18 | 0.18 | 0.18 | 0.18 | 0.17 |
| 1 | 0.31 | 0.28 | 0.27 | 0.26 | 0.24 | 0.23 | 0.23 | 0.23 | 0.22 | 0.22 | 0.22 | 0.22 |
| 1.5 | 0.38 | 0.35 | 0.34 | 0.32 | 0.30 | 0.28 | 0.27 | 0.27 | 0.27 | 0.27 | 0.26 | 0.25 |
| 2 | 0.45 | 0.41 | 0.40 | 0.37 | 0.35 | 0.33 | 0.32 | 0.32 | 0.31 | 0.30 | 0.29 | 0.29 |
| 3 | 0.56 | 0.52 | 0.50 | 0.47 | 0.43 | 0.40 | 0.39 | 0.38 | 0.38 | 0.37 | 0.36 | 0.35 |
| 4 | 0.67 | 0.61 | 0.58 | 0.55 | 0.50 | 0.47 | 0.45 | 0.43 | 0.43 | 0.42 | 0.41 | 0.40 |
| 5 | 0.75 | 0.69 | 0.66 | 0.62 | 0.56 | 0.53 | 0.50 | 0.48 | 0.48 | 0.47 | 0.46 | 0.44 |
| 7 | 0.90 | 0.83 | 0.80 | 0.75 | 0.68 | 0.63 | 0.60 | 0.58 | 0.58 | 0.56 | 0.54 | 0.52 |
| 9 | 0.99 | 0.96 | 0.92 | 0.86 | 0.78 | 0.73 | 0.69 | 0.66 | 0.66 | 0.63 | 0.62 | 0.58 |
| 11 | 1.07 | 1.05 | 1.03 | 0.97 | 0.87 | 0.81 | 0.77 | 0.73 | 0.73 | 0.70 | 0.68 | 0.65 |
| 15 | 1.08 | 1.18 | 1.22 | 1.15 | 1.04 | 0.96 | 0.91 | 0.87 | 0.87 | 0.83 | 0.80 | 0.76 |
| 20 | 1.08 | 1.25 | 1.36 | 1.34 | 1.23 | 1.13 | 1.07 | 1.02 | 1.02 | 0.97 | 0.94 | 0.88 |
| 25 | 1.08 | 1.25 | 1.50 | 1.47 | 1.39 | 1.29 | 1.21 | 1.15 | 1.15 | 1.10 | 1.06 | 0.99 |
| 30 | 1.08 | 1.25 | 1.50 | 1.57 | 1.54 | 1.43 | 1.34 | 1.27 | 1.27 | 1.21 | 1.17 | 1.09 |
| 40 | 1.08 | 1.25 | 1.50 | 1.67 | 1.75 | 1.68 | 1.58 | 1.50 | 1.50 | 1.42 | 1.37 | 1.27 |
| 50 | 1.08 | 1.25 | 1.50 | 1.67 | 1.90 | 1.89 | 1.80 | 1.70 | 1.70 | 1.61 | 1.55 | 1.44 |
| 60 | 1.08 | 1.25 | 1.50 | 1.67 | 2.00 | 2.06 | 1.99 | 1.89 | 1.89 | 1.79 | 1.72 | 1.59 |
| 75 | 1.08 | 1.25 | 1.50 | 1.67 | 2.00 | 2.23 | 2.23 | 2.14 | 2.14 | 2.03 | 1.95 | 1.80 |
| 90 | 1.08 | 1.25 | 1.50 | 1.67 | 2.00 | 2.42 | 2.41 | 2.36 | 2.36 | 2.26 | 2.17 | 1.99 |
| 115 | 1.08 | 1.25 | 1.50 | 1.67 | 2.00 | 2.42 | 2.42 | 2.63 | 2.67 | 2.59 | 2.49 | 2.29 |
| 150 | 1.08 | 1.25 | 1.50 | 1.67 | 2.00 | 2.42 | 2.42 | 2.75 | 2.94 | 2.96 | 2.88 | 2.66 |
| 200 | 1.08 | 1.25 | 1.50 | 1.67 | 2.00 | 2.42 | 2.42 | 2.75 | 3.17 | 3.30 | 3.32 | 3.13 |
| 250 | 1.08 | 1.25 | 1.50 | 1.67 | 2.00 | 2.42 | 2.42 | 2.75 | 3.17 | 3.58 | 3.60 | 3.54 |
| 300 | 1.08 | 1.25 | 1.50 | 1.67 | 2.00 | 2.42 | 2.42 | 2.75 | 3.17 | 3.58 | 3.89 | 3.88 |
| 350 | 1.08 | 1.25 | 1.50 | 1.67 | 2.00 | 2.42 | 2.42 | 2.75 | 3.17 | 3.58 | 3.92 | 4.15 |
| 400 | 1.08 | 1.25 | 1.50 | 1.67 | 2.00 | 2.42 | 2.42 | 2.75 | 3.17 | 3.58 | 3.92 | 4.34 |
| 500 | 1.08 | 1.25 | 1.50 | 1.67 | 2.00 | 2.42 | 2.42 | 2.75 | 3.17 | 3.58 | 3.92 | 4.75 |

Table 6A-9
 Critical Depth in Feet for Pipe Arch Culverts, 2 2/3 x 1/2 Inch Corrugations
 (Critical depth cannot be greater than culvert rise)

| Q (cfs) | Nominal Dimensions in inches | | | | | | | | | | | |
|------------|------------------------------|-------|-------|-------|-------|-------|-------|-------|-------|-------|-------|-------|
| | 40x31 | 46x31 | 53x41 | 60x46 | 66x51 | 73x55 | 81x59 | 87x63 | 95x67 | 103x7 | 112x7 | 117x7 |
| 0.1 | 0.10 | 0.09 | 0.08 | 0.07 | 0.07 | 0.07 | 0.06 | 0.06 | 0.05 | 0.05 | 0.05 | 0.05 |
| 0.3 | 0.16 | 0.16 | 0.16 | 0.16 | 0.15 | 0.14 | 0.13 | 0.12 | 0.11 | 0.11 | 0.10 | 0.10 |
| 0.6 | 0.21 | 0.21 | 0.21 | 0.20 | 0.20 | 0.20 | 0.20 | 0.19 | 0.18 | 0.17 | 0.16 | 0.16 |
| 1 | 0.27 | 0.27 | 0.26 | 0.25 | 0.25 | 0.25 | 0.24 | 0.25 | 0.25 | 0.24 | 0.23 | 0.22 |
| 1.5 | 0.33 | 0.32 | 0.31 | 0.31 | 0.30 | 0.29 | 0.29 | 0.29 | 0.28 | 0.28 | 0.28 | 0.29 |
| 2 | 0.38 | 0.37 | 0.36 | 0.35 | 0.34 | 0.33 | 0.33 | 0.32 | 0.32 | 0.32 | 0.32 | 0.32 |
| 3 | 0.46 | 0.45 | 0.43 | 0.42 | 0.41 | 0.40 | 0.40 | 0.39 | 0.38 | 0.37 | 0.37 | 0.37 |
| 4 | 0.53 | 0.52 | 0.50 | 0.48 | 0.47 | 0.46 | 0.45 | 0.44 | 0.44 | 0.43 | 0.42 | 0.42 |
| 5 | 0.60 | 0.58 | 0.56 | 0.54 | 0.53 | 0.51 | 0.50 | 0.49 | 0.49 | 0.48 | 0.47 | 0.46 |
| 7 | 0.71 | 0.69 | 0.66 | 0.64 | 0.62 | 0.60 | 0.58 | 0.57 | 0.56 | 0.55 | 0.55 | 0.54 |
| 9 | 0.81 | 0.78 | 0.75 | 0.72 | 0.70 | 0.68 | 0.66 | 0.65 | 0.63 | 0.62 | 0.61 | 0.60 |
| 11 | 0.91 | 0.87 | 0.83 | 0.80 | 0.78 | 0.75 | 0.73 | 0.71 | 0.70 | 0.68 | 0.67 | 0.66 |
| 15 | 1.07 | 1.02 | 0.98 | 0.94 | 0.91 | 0.88 | 0.85 | 0.83 | 0.81 | 0.79 | 0.78 | 0.77 |
| 20 | 1.25 | 1.20 | 1.14 | 1.09 | 1.06 | 1.02 | 0.98 | 0.96 | 0.94 | 0.91 | 0.90 | 0.88 |
| 25 | 1.42 | 1.35 | 1.29 | 1.23 | 1.19 | 1.14 | 1.10 | 1.07 | 1.05 | 1.02 | 1.00 | 0.98 |
| 30 | 1.57 | 1.49 | 1.42 | 1.35 | 1.31 | 1.26 | 1.21 | 1.18 | 1.15 | 1.12 | 1.10 | 1.07 |
| 40 | 1.83 | 1.75 | 1.66 | 1.58 | 1.52 | 1.46 | 1.41 | 1.37 | 1.33 | 1.30 | 1.27 | 1.24 |
| 50 | 2.06 | 1.97 | 1.87 | 1.78 | 1.72 | 1.65 | 1.59 | 1.54 | 1.50 | 1.46 | 1.43 | 1.39 |
| 60 | 2.25 | 2.18 | 2.07 | 1.97 | 1.90 | 1.82 | 1.75 | 1.69 | 1.65 | 1.60 | 1.57 | 1.53 |
| 75 | 2.46 | 2.45 | 2.34 | 2.23 | 2.14 | 2.05 | 1.97 | 1.91 | 1.86 | 1.80 | 1.76 | 1.72 |
| 90 | 2.57 | 2.67 | 2.58 | 2.46 | 2.37 | 2.27 | 2.18 | 2.11 | 2.05 | 1.99 | 1.94 | 1.89 |
| 115 | 2.73 | 2.91 | 2.92 | 2.81 | 2.71 | 2.59 | 2.49 | 2.41 | 2.34 | 2.27 | 2.21 | 2.15 |
| 150 | 2.73 | 3.10 | 3.25 | 3.22 | 3.13 | 3.00 | 2.88 | 2.78 | 2.70 | 2.62 | 2.55 | 2.48 |
| 200 | 2.73 | 3.17 | 3.48 | 3.63 | 3.62 | 3.51 | 3.37 | 3.26 | 3.16 | 3.06 | 2.99 | 2.90 |
| 250 | 2.73 | 3.17 | 3.60 | 3.84 | 3.98 | 3.92 | 3.80 | 3.68 | 3.57 | 3.46 | 3.37 | 3.28 |
| 300 | 2.73 | 3.17 | 3.60 | 4.04 | 4.19 | 4.24 | 4.17 | 4.06 | 3.95 | 3.82 | 3.73 | 3.62 |
| 350 | 2.73 | 3.17 | 3.60 | 4.04 | 4.34 | 4.47 | 4.46 | 4.39 | 4.29 | 4.16 | 4.05 | 3.94 |
| 400 | 2.73 | 3.17 | 3.60 | 4.04 | 4.50 | 4.59 | 4.68 | 4.67 | 4.60 | 4.47 | 4.36 | 4.24 |
| 500 | 2.73 | 3.17 | 3.60 | 4.04 | 4.50 | 4.85 | 4.95 | 5.08 | 5.10 | 5.01 | 4.91 | 4.79 |

Table 6A-10
 Critical Depth in Feet for Pipe Arch Culverts, 3 x 1 Inch Corrugations
 (Critical depth cannot be greater than culvert rise)

| d / D | T / D | A _o / A | P _o / P | R _o / R | A _o R _o ^{0.67} / AR ^{0.67} |
|-------|-------|--------------------|--------------------|--------------------|--|
| 0.00 | 0.000 | 0.000 | 0.000 | 0.000 | 0.000 |
| 0.05 | 0.436 | 0.019 | 0.144 | 0.130 | 0.005 |
| 0.10 | 0.600 | 0.052 | 0.205 | 0.254 | 0.021 |
| 0.15 | 0.714 | 0.094 | 0.253 | 0.372 | 0.049 |
| 0.20 | 0.800 | 0.142 | 0.295 | 0.482 | 0.088 |
| 0.25 | 0.866 | 0.196 | 0.333 | 0.587 | 0.137 |
| 0.30 | 0.917 | 0.252 | 0.369 | 0.684 | 0.196 |
| 0.35 | 0.954 | 0.312 | 0.403 | 0.774 | 0.263 |
| 0.40 | 0.980 | 0.374 | 0.436 | 0.857 | 0.337 |
| 0.45 | 0.995 | 0.436 | 0.468 | 0.932 | 0.417 |
| 0.50 | 1.000 | 0.500 | 0.500 | 1.000 | 0.500 |
| 0.55 | 0.995 | 0.564 | 0.532 | 1.060 | 0.586 |
| 0.60 | 0.980 | 0.626 | 0.564 | 1.111 | 0.672 |
| 0.65 | 0.954 | 0.688 | 0.597 | 1.153 | 0.756 |
| 0.70 | 0.917 | 0.748 | 0.631 | 1.185 | 0.837 |
| 0.75 | 0.866 | 0.804 | 0.667 | 1.207 | 0.912 |
| 0.80 | 0.800 | 0.858 | 0.705 | 1.217 | 0.977 |
| 0.85 | 0.714 | 0.906 | 0.747 | 1.213 | 1.030 |
| 0.90 | 0.600 | 0.948 | 0.795 | 1.192 | 1.066 |
| 0.95 | 0.436 | 0.981 | 0.856 | 1.146 | 1.075 |
| 1.00 | 0.000 | 1.000 | 1.000 | 1.000 | 1.000 |

$$A_{full} = \pi(D^2/4)$$

$$P_{full} = \pi D$$

$$R_{full} = D/4$$

$$V = (1.486/n)R^{0.67}S^{0.5}$$

$$Q = (1.486/n)AR^{0.67}S^{0.5}$$

Variables:

d = Depth

D = Diameter

T = Top width

A_o = Part full Flow Area

A = Area, pipe flowing full

P_o = Part full Wetted Perimeter

P = Wetted Perimeter, pipe flowing full

R_o = Part full Hydraulic Radius

R = Hydraulic Radius, pipe flowing full

n = Manning's n-value

V = Velocity, feet per second

Q = Discharge, cfs

S = Slope, ft/ft

Table 6A-11
Cross Sectional Properties of Circular Pipes Flowing Partly Full

6.07.2 EXAMPLE PROBLEMS

6.07.2.1 EXAMPLE PROBLEM #1: CIRCULAR CULVERT SOLUTION BY HAND COMPUTATIONS

GIVEN:

A culvert is proposed for a new roadway crossing as shown in Figure 6A-11. The required design storm frequency is the 50-year storm event and 1 foot of freeboard is required at the roadway shoulder. Roadway overtopping will not be allowed. The following information is known:

- 50-year flow rate (Q_{50}) = 25 ft³/s
- Invert elevation at inlet = 341.25 feet
- Invert elevation at outlet = 340.70 feet
- Natural streambed slope = 0.5% (0.005 ft/ft)
- Tailwater depth for the 50-year storm = 1.8 feet
- Approximate culvert length = 110 feet (endwall to endwall)
- Roadway shoulder elevation = 345.32 feet
- Minimum culvert size = 36 inches
- Concrete Pipe Manning's 'n' = 0.013

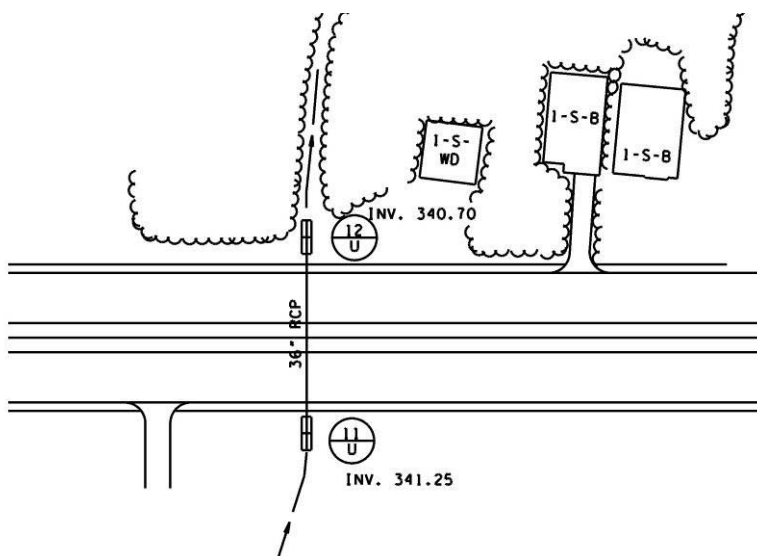

Figure 6A-11
Culvert Roadway Crossing

FIND:

Using manual computations methods, select a circular pipe culvert for this site. Concrete pipe with Type "U" endwalls, which correspond to an inlet condition of square edge with headwall, will be required per TDOT design guidelines.

SOLUTION:

Step1: Record Basic Data on Culvert Design Form (see Section 6.05.1)

Record the known data on a copy of the culvert design form shown in Figure 6A-2. The completed design form for this example problem is shown in Figure 6A-12. The outlet elevation is 340.70 feet (inlet elevation minus the length of the culvert times the bed slope).

| PROJECT : S.R.-XYZ Davidson County, Tennessee | | STATION : 1+90.00 SHEET 1 OF 1 | | CULVERT DESIGN FORM DESIGNER / DATE : JC / 2/2004 REVIEWER / DATE : TBS / 2/2004 | | | | | | | | | | | | | | | | | | | | | | | | | | | | | | | | | | | | | | | | | | | | | | | | | | | | | | | | | | | | | | | | | | | | | | | | | | | | | | | | | | | | | | | | | | | | | | | | | | | | | | | | | | | | | | | | | | | | |
|--|-------------------|--|------------------------|--|----------|--|-------------------|--------------------------|------------------------|--------------------|----------------|-------|---------------------------------|-----------------|----------|--|--|--|-----------------------------|-----------------|----------|---------------|--|--|--|--|----------------|--|--|--|--|--|--|--|------------------------|---------------------|----------|---------------------------------|--------|----------------|---------------------|--------------------|----------------|-------|---------------------------------|--|--|--|------------|----|----|------|------|---|--------|-----|-----|-----|-----|-----|------|--------|--------|------|--|--|--|--|--|--|--|--|--|--|--|--|--|--|--|--|--|--|--|--|--|--|--|--|--|--|--|--|--|--|--|--|--|--|--|--|--|--|--|--|--|--|--|--|--|--|--|--|--|--|--|--|--|--|--|--|
| HYDROLOGICAL DATA METHOD: <input type="checkbox"/> RATIONAL DRAINAGE AREA: _____ <input type="checkbox"/> STREAM SLOPE: 0.005 CHANNEL SHAPE: TRAPEZOIDAL ROUTING: _____ <input type="checkbox"/> OTHER: _____ | | <p style="text-align: right;"> $S = S_o - \text{FALL} / L_o$ $S = 0.005$ $L_o = 110.0 \text{ (ft)}$ </p> | | | | | | | | | | | | | | | | | | | | | | | | | | | | | | | | | | | | | | | | | | | | | | | | | | | | | | | | | | | | | | | | | | | | | | | | | | | | | | | | | | | | | | | | | | | | | | | | | | | | | | | | | | | | | | | | | | | | | | |
| DESIGN FLOWS/TAIWATER R.I. (YEARS) FLOW (CFS) TW (FT) 10 25 N/A | | <table border="1" style="width:100%; border-collapse: collapse;"> <thead> <tr> <th rowspan="2">CULVERT DESCRIPTION: MATERIAL - SHAPE - SIZE - ENTRANCE</th> <th rowspan="2">TOTAL FLOW (Q)</th> <th rowspan="2">FLOW PER BARREL (Q/N)</th> <th colspan="10">HEADWATER CALCULATIONS</th> <th rowspan="2">CONTROL HEADWATER ELEVATION</th> <th rowspan="2">OUTLET VELOCITY</th> <th rowspan="2">COMMENTS</th> </tr> <tr> <th colspan="5">INLET CONTROL</th> <th colspan="5">OUTLET CONTROL</th> </tr> <tr> <th></th> <th></th> <th></th> <th>HW₁/D (2)</th> <th>HW₁ (3)</th> <th>FALL (3)</th> <th>EL_{h₁} (4)</th> <th>TW (5)</th> <th>d_c</th> <th>d_c+D/2</th> <th>h_o (6)</th> <th>k_e</th> <th>H (7)</th> <th>EL_{h_o} (8)</th> <th></th> <th></th> <th></th> </tr> </thead> <tbody> <tr> <td>36" R.C.P.</td> <td>25</td> <td>25</td> <td>0.79</td> <td>2.37</td> <td>0</td> <td>343.62</td> <td>1.8</td> <td>1.6</td> <td>2.3</td> <td>2.3</td> <td>0.5</td> <td>0.45</td> <td>343.45</td> <td>343.62</td> <td>6.78</td> <td></td> <td></td> </tr> <tr> <td> </td> <td> </td> <td> </td> <td> </td> <td> </td> <td> </td> <td> </td> <td> </td> <td> </td> <td> </td> <td> </td> <td> </td> <td> </td> <td> </td> <td> </td> <td> </td> <td> </td> <td> </td> </tr> <tr> <td> </td> <td> </td> <td> </td> <td> </td> <td> </td> <td> </td> <td> </td> <td> </td> <td> </td> <td> </td> <td> </td> <td> </td> <td> </td> <td> </td> <td> </td> <td> </td> <td> </td> <td> </td> </tr> <tr> <td> </td> <td> </td> <td> </td> <td> </td> <td> </td> <td> </td> <td> </td> <td> </td> <td> </td> <td> </td> <td> </td> <td> </td> <td> </td> <td> </td> <td> </td> <td> </td> <td> </td> <td> </td> </tr> </tbody> </table> | | | | CULVERT DESCRIPTION: MATERIAL - SHAPE - SIZE - ENTRANCE | TOTAL FLOW (Q) | FLOW PER BARREL (Q/N) | HEADWATER CALCULATIONS | | | | | | | | | | CONTROL HEADWATER ELEVATION | OUTLET VELOCITY | COMMENTS | INLET CONTROL | | | | | OUTLET CONTROL | | | | | | | | HW ₁ /D (2) | HW ₁ (3) | FALL (3) | EL _{h₁} (4) | TW (5) | d _c | d _c +D/2 | h _o (6) | k _e | H (7) | EL _{h_o} (8) | | | | 36" R.C.P. | 25 | 25 | 0.79 | 2.37 | 0 | 343.62 | 1.8 | 1.6 | 2.3 | 2.3 | 0.5 | 0.45 | 343.45 | 343.62 | 6.78 | | | | | | | | | | | | | | | | | | | | | | | | | | | | | | | | | | | | | | | | | | | | | | | | | | | | | | | | |
| CULVERT DESCRIPTION: MATERIAL - SHAPE - SIZE - ENTRANCE | TOTAL FLOW (Q) | FLOW PER BARREL (Q/N) | HEADWATER CALCULATIONS | | | | | | | | | | CONTROL HEADWATER ELEVATION | OUTLET VELOCITY | COMMENTS | | | | | | | | | | | | | | | | | | | | | | | | | | | | | | | | | | | | | | | | | | | | | | | | | | | | | | | | | | | | | | | | | | | | | | | | | | | | | | | | | | | | | | | | | | | | | | | | | | | | | | | | | |
| | | | INLET CONTROL | | | | | OUTLET CONTROL | | | | | | | | | | | | | | | | | | | | | | | | | | | | | | | | | | | | | | | | | | | | | | | | | | | | | | | | | | | | | | | | | | | | | | | | | | | | | | | | | | | | | | | | | | | | | | | | | | | | | | | | | | | | | | | | |
| | | | HW ₁ /D (2) | HW ₁ (3) | FALL (3) | EL _{h₁} (4) | TW (5) | d _c | d _c +D/2 | h _o (6) | k _e | H (7) | EL _{h_o} (8) | | | | | | | | | | | | | | | | | | | | | | | | | | | | | | | | | | | | | | | | | | | | | | | | | | | | | | | | | | | | | | | | | | | | | | | | | | | | | | | | | | | | | | | | | | | | | | | | | | | | | | | | | | | |
| 36" R.C.P. | 25 | 25 | 0.79 | 2.37 | 0 | 343.62 | 1.8 | 1.6 | 2.3 | 2.3 | 0.5 | 0.45 | 343.45 | 343.62 | 6.78 | | | | | | | | | | | | | | | | | | | | | | | | | | | | | | | | | | | | | | | | | | | | | | | | | | | | | | | | | | | | | | | | | | | | | | | | | | | | | | | | | | | | | | | | | | | | | | | | | | | | | | | | | |
| | | | | | | | | | | | | | | | | | | | | | | | | | | | | | | | | | | | | | | | | | | | | | | | | | | | | | | | | | | | | | | | | | | | | | | | | | | | | | | | | | | | | | | | | | | | | | | | | | | | | | | | | | | | | | | | | | | | | | | | | |
| | | | | | | | | | | | | | | | | | | | | | | | | | | | | | | | | | | | | | | | | | | | | | | | | | | | | | | | | | | | | | | | | | | | | | | | | | | | | | | | | | | | | | | | | | | | | | | | | | | | | | | | | | | | | | | | | | | | | | | | | |
| | | | | | | | | | | | | | | | | | | | | | | | | | | | | | | | | | | | | | | | | | | | | | | | | | | | | | | | | | | | | | | | | | | | | | | | | | | | | | | | | | | | | | | | | | | | | | | | | | | | | | | | | | | | | | | | | | | | | | | | | |
| TECHNICAL FOOTNOTES : (1) USE Q/NB FOR BOX CULVERTS (2) HW ₁ /D = HW ₁ /D OR HW ₁ /D FROM DESIGN CHARTS (3) FALL = HW ₁ - (EL _{hd} - EL _{of}); FALL IS ZERO FOR CULVERTS ON GRADE | | (4) EL _{h₁} = HW ₁ + EL _i (INVERT OF INLET CONTROL SECTION) (5) TW BASED ON DOWN STREAM CONTROL OR FLOW DEPTH IN CHANNEL. (6) h _o = TW or (d _c +D)/2 (WHICHEVER IS GREATER) (7) H = [1 + k _e + (K _u n ² L) / R ^{1.33}] v ² / 2g WHERE K _u = 19.63 (29 IN ENGLISH UNITS) (8) EL _{h_o} = EL _o + H + h _o | | | | | | | | | | | | | | | | | | | | | | | | | | | | | | | | | | | | | | | | | | | | | | | | | | | | | | | | | | | | | | | | | | | | | | | | | | | | | | | | | | | | | | | | | | | | | | | | | | | | | | | | | | | | | | | | | | | | | | |
| SUBSCRIPT DEFINITIONS : n. APPROXIMATE CULVERT FACE hd. DESIGN HEADWATER h ₁ . HEADWATER IN INLET CONTROL ho. HEADWATER IN OUTLET CONTROL i. INLET CONTROL SECTION o. OUTLET of. STREAMBED AT CULVERT FACE tw. TAILWATER | | COMMENTS / DISCUSSION : | | CULVERT BARREL SELECTED : SIZE : 36" SHAPE : CIRCULAR MATERIAL : CONCRETE n 0.013 ENTRANCE : SQUARE EDGE WITH HEADWALL | | | | | | | | | | | | | | | | | | | | | | | | | | | | | | | | | | | | | | | | | | | | | | | | | | | | | | | | | | | | | | | | | | | | | | | | | | | | | | | | | | | | | | | | | | | | | | | | | | | | | | | | | | | | | | | | | | | | |

Figure 6A-12
Completed Culvert Design Form (Problem #1)

Step 2: Assume Trial Culvert Size

Begin the computations by assuming a trial pipe diameter of 36 inches. Because there is only one culvert barrel, the design discharge of 25 cfs is entered into the columns "Total Flow" and "Flow per Barrel."

Step3: Determine Inlet Control Headwater Depth HW_i (see Section 6.05.2.1)

Determine the inlet control headwater depth (HW_i) using the appropriate nomograph from HDS-5 (inlet control nomographs for all culvert types can be found in HDS-5). Referring to Figure 6A-13, from the left, projecting from the culvert diameter of 36 inches through a discharge of 25 cfs, yields an approximate value of 0.79 for HW/D on the first headwater depth scale. This value is entered into the HW/D column of the Culvert Design Form (Figure 6A-12). This value is then multiplied by the diameter to obtain a value for HW_i of 2.37 feet, which is also entered on the culvert design form. Adding the depth to the culvert inlet elevation yields an inlet control headwater elevation of 343.62 feet. This value is entered into the EL_{hi} column of the culvert design form.

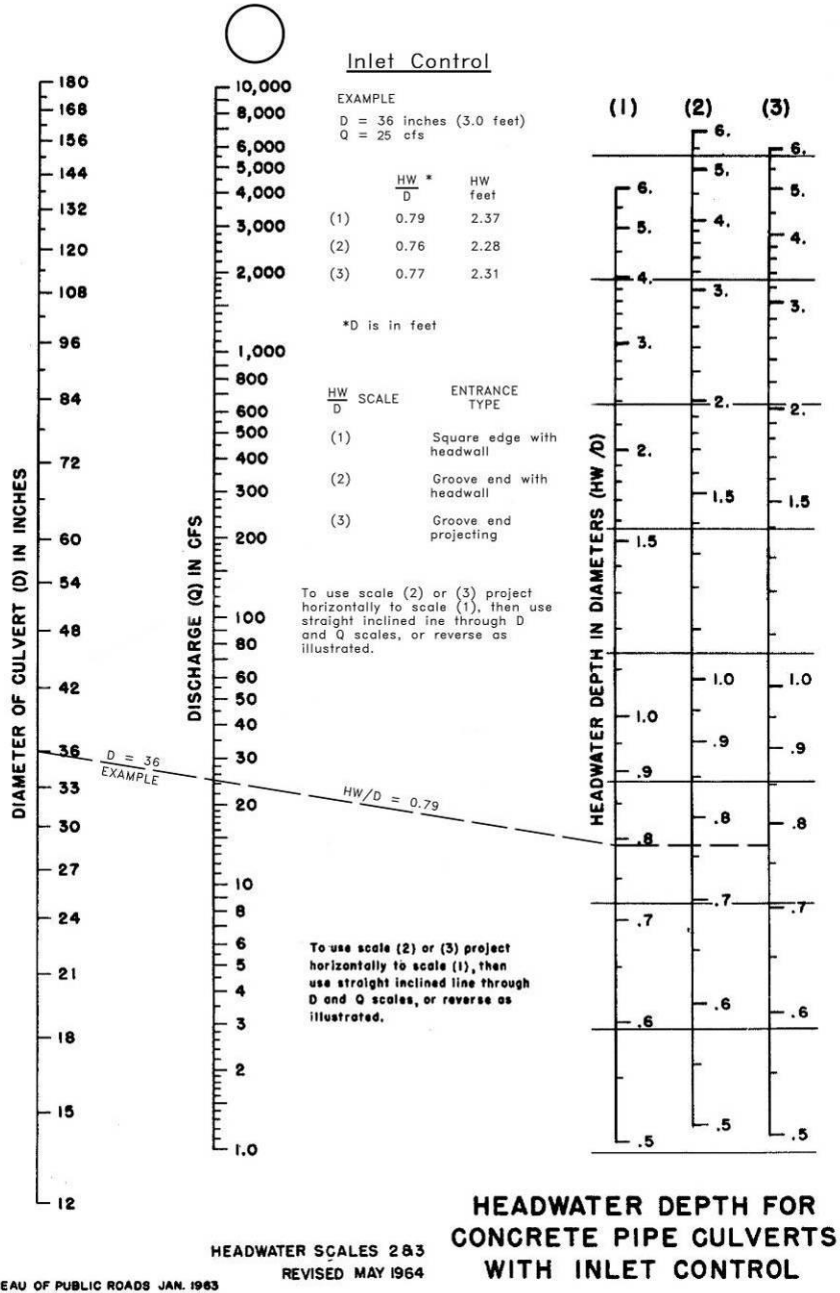

Figure 6A-13
 Completed Inlet Control Headwater Chart (Problem #1)
 Reference: USDOT, FHWA, HDS-5 (1985)

Step 4: Determine the Outlet Control Headwater Elevation HW_o (see Section 6.05.2.2)

To determine the outlet control headwater elevation, it is first necessary to determine h_o , the effective tailwater depth, which is the greater of the quantity $(d_c + D) / 2$

or the tailwater depth. Note that d_c is the critical depth in the culvert and D is the proposed culvert diameter. From the upper graph of Figure 6A-7, entering the x-axis with a Q_{design} of 25 cfs, the designer projects vertically to the 3-foot curve. At the intersection point with the curve, project horizontally to the y-axis to obtain an approximate critical depth of 1.6 feet. As an alternate, a critical depth of 1.61 feet could be read directly from Table 6A-7. A critical depth in the culvert of 1.61 feet will be used. Thus, $(d_c + D) / 2$ is equal to 2.3 feet. Since this is greater than the given tailwater depth of 1.8 feet, h_o will be 2.3 feet. Again, these results are entered into the culvert design form.

Before determining the outlet control headwater depth, it is necessary for the designer to determine the appropriate entrance loss coefficient (K_e). This can be obtained from Table 6A-6, and is determined to be 0.5 for concrete pipes with an inlet condition of square edge with headwalls.

Since the Manning's n-value assumed for the nomograph is 0.012, it is also necessary to adjust the culvert length to account for the actual culvert n-value of 0.013. Equation 6-2 yields an adjusted culvert length of 129 feet computed as follows:

$$L_1 = 110 (0.013 / 0.012)^2$$

$$L_1 = 129.09 \text{ feet}$$

The head loss across the culvert, H , is found from the nomograph shown in Figure 6A-14 (an original of this nomograph, as well as others, can be found in HDS-5). A line is projected from the equivalent length of 129 feet on the $K_e = 0.5$ scale to 36 inches on the culvert diameter scale. Another line is then projected from the 25 cfs mark on the discharge scale through the point where the first line crosses the turning line, then further extended to the Head scale. This yields a value of approximately 0.45 feet on the Head scale. H and h_o are then added to the culvert outlet elevation to determine an outlet control headwater elevation, HW_o , of 343.45 feet.

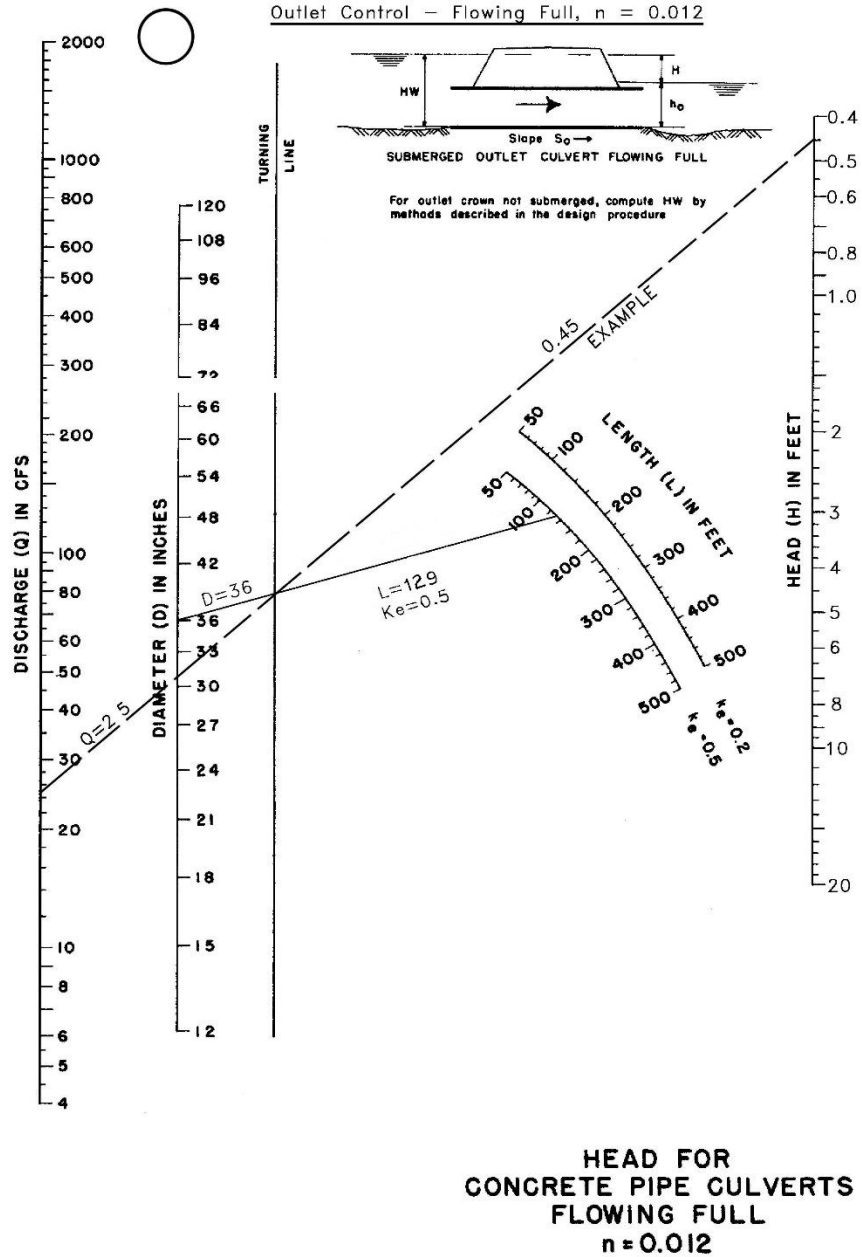

Figure 6A-14
Completed Outlet Control Headwater Chart (Problem #1)
Reference: USDOT, FHWA, HDS-5 (1985)

Step 5: Determine the Controlling Headwater Depth (see Section 6.05.2.3)

Compare the inlet control headwater elevation of 343.62 feet to the outlet control headwater elevation of 343.45 feet. Since the inlet control headwater elevation is greater, the culvert will operate in inlet control and the headwater elevation will be 343.62 feet.

Since the allowable headwater elevation is 344.32 feet, the trial culvert size will be acceptable. Had the controlling headwater elevation been greater than the allowable, it would have been necessary to select a larger culvert size and conduct another trial. Further, since the controlling headwater elevation is less than the allowable elevation, it is possible that a smaller pipe could still provide an acceptable headwater elevation. However, since the minimum culvert size is 36 inches, no further trials will be conducted.

Step 6: Determine Outlet Depth and Velocity (see Section 6.05.4)

The first step of determining the outlet flow conditions will be to determine the depth of the flow (d_o) at the culvert outlet. Since the culvert will operate in inlet control, the flow will be supercritical and d_o will likely be equal to the normal depth. Thus, Table 6A-11 may be used to compute the outlet depth in the following manner:

- One of the columns in Table 6A-11 utilizes a factor which is equal to the flow area multiplied by hydraulic radius to the $\frac{2}{3}$ (two-thirds) power. Normal depth is computed using Manning's Equation, which may be re-written for this problem as:

$$\begin{aligned} A_o R_o^{0.667} &= (Q n) / (1.486 S^{0.5}) = 3.093 \\ &= [25 (0.013)] / [1.486 (0.005)^{0.5}] \\ &= 3.093 \end{aligned}$$

Where:

- A_o = flow area at the culvert outlet, (ft²)
- R_o = hydraulic radius of the flow at the culvert outlet, (ft)
- Q = design discharge, (ft³/s)
- n = Manning's n-value, (unitless)
- S = culvert slope, (ft/ft)

- Since the selected culvert diameter is 3 feet, the same factor may be computed for full flow as:

$$\begin{aligned} A R^{0.667} &= 5.835 \\ (7.065 \text{ ft}^2)(0.75 \text{ ft})^{0.667} &= 5.835 \end{aligned}$$

Where:

- A = area of the culvert flowing full, (ft²)
- R = hydraulic radius of the culvert, flowing full, (ft)

- Based upon these computations, the ratio $A_o R_o^{0.667} / A R^{0.667}$ equals 0.530. Using Table 6A-11, the corresponding ratio of depth to diameter (d / D) would be approximately equal to 0.518, which yields an outlet depth of 1.55 feet. Since the culvert length is more than 50 times the computed depth, this depth may be considered to be accurate.

Again, using Table 6A-11, by interpolation, the ratio A_o / A is approximated to be 0.522 which yields a flow area of 3.69 square feet. Dividing the design discharge of 25

cfs by the computed flow area yields an outlet velocity of 6.78 fps. Since this velocity is not excessive, it will be possible to line the downstream channel with riprap to provide the required scour protection, and the culvert size selection may be considered complete.

6.07.2.2 EXAMPLE PROBLEM #2: CIRCULAR CULVERT USING HY-8

GIVEN:

Use the site data given in Example Problem #1 (Section 6.07.2.1).

FIND:

Using the data from Example Problem #1, design the proposed roadway culvert using computer software HY-8 as the computational method.

SOLUTION:

The following sections provide a procedure for solving Problem 1 using HY-8.

6.07.2.2.1 DATA INPUT

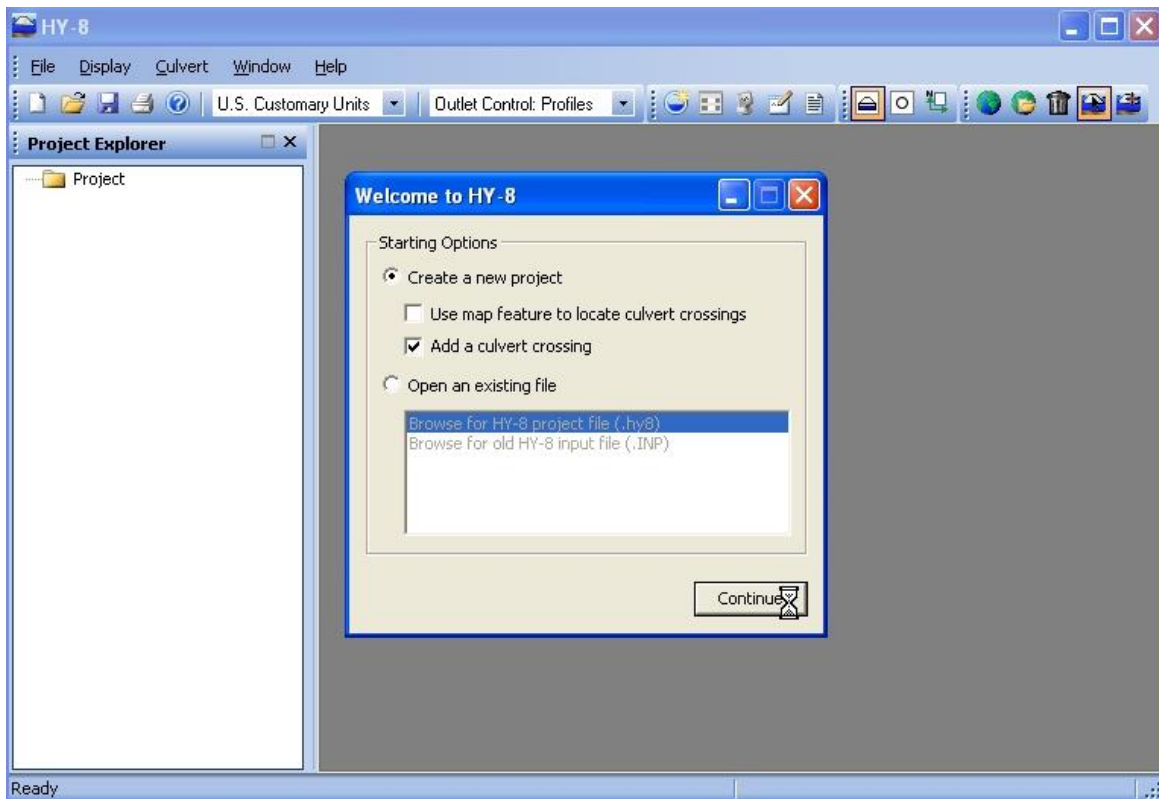

Figure 6A-15
HY-8 Main Menu Screen

Step 1:

Upon accessing HY-8, the main screen shown in Figure 6A-15, allows the user to select the procedure required for the design problem given. As see in Figure 6A-15, other design options are available, but will not be discussed here. To start the problem, the

designer should toggle Add a culvert crossing and select Continue. The designer will then be prompted for the project data.

Step 2:

Using HY-8, the data can be entered for the given conditions. Figure 6A-16 shows the HY-8 data input screen for the given site conditions.

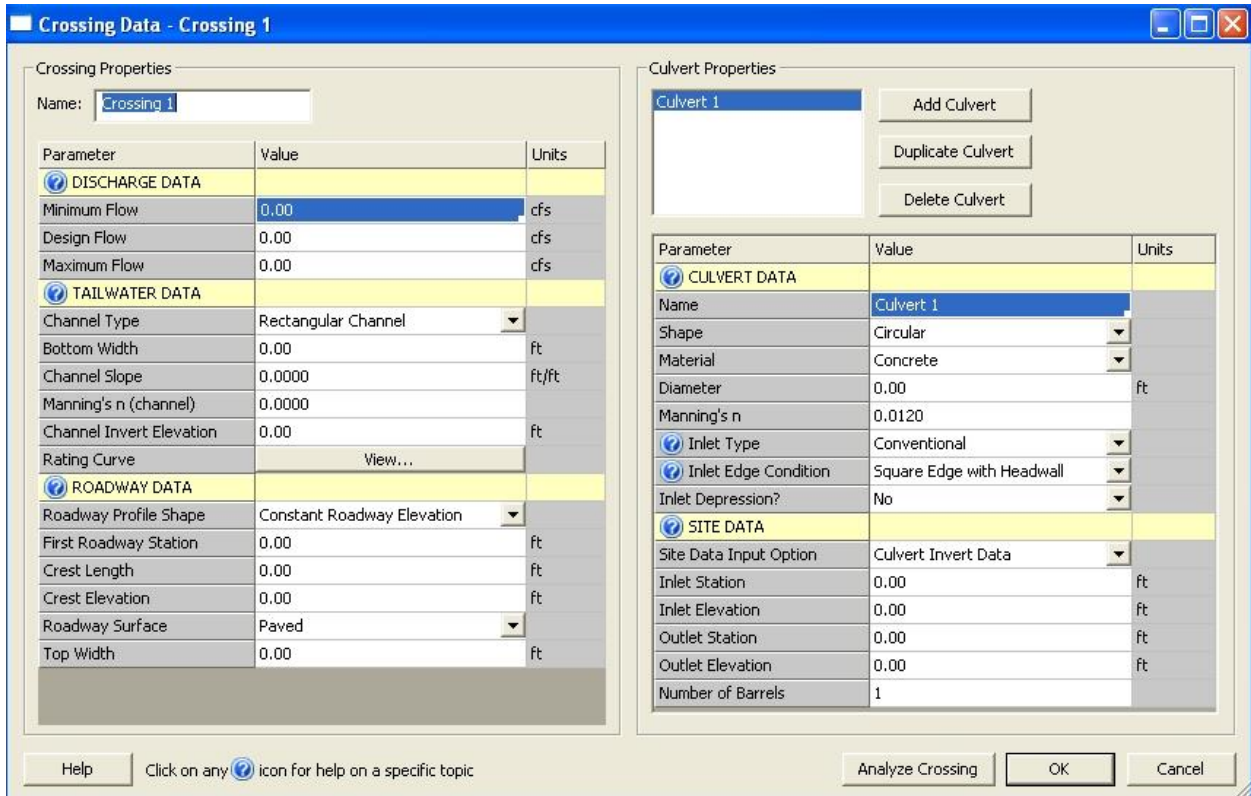

Figure 6A-16
HY-8 Data Input Screen

Step 3:

Enter the culvert site data for the given problem parameters. Two possibilities exist for entering this data. The user can select either the “culvert-inlet” option which prompts the user for the inlet and outlet station and elevations for the culvert along the channel, or they can enter embankment and toe data by selecting the “embankment-toe” option. HY-8 uses the embankment and toe data to create the invert data for the culvert if the “embankment-toe” option is selected. For this application, the inlet and outlet station and elevations are known; therefore, the designer will select the “culvert-invert” option. The HY-8 culvert site data (culvert-invert) screen is shown in Figure 6A-17.

| SITE DATA | | |
|------------------------|---------------------|----|
| Site Data Input Option | Culvert Invert Data | |
| Inlet Station | 0.00 | ft |
| Inlet Elevation | 341.25 | ft |
| Outlet Station | 110.00 | ft |
| Outlet Elevation | 340.70 | ft |
| Number of Barrels | 1 | |

Figure 6A-17
HY-8 Culvert Site Data (Invert Data) Input Screen

Step 4:

The designer will then enter culvert characteristics for this site such as the shape, size, material, and inlet conditions of the proposed culvert. HY-8 provides a Manning’s n-value based on the culvert material chosen by the designer. Inlet information can be for either a conventional inlet configuration or an improved inlet (side or slope tapered options are available). The HY-8 input screen for this Step is shown in Figure 6A-18.

| Parameter | Value | Units |
|----------------------|---------------------------|-------|
| CULVERT DATA | | |
| Name | Culvert 1 | |
| Shape | Circular | |
| Material | Concrete | |
| Diameter | 3.00 | ft |
| Manning's n | 0.0130 | |
| Inlet Type | Conventional | |
| Inlet Edge Condition | Square Edge with Headwall | |
| Inlet Depression? | No | |

Figure 6A-18
HY-8 Culvert Data Input Screen

Step 5:

The designer will input the downstream channel information such as shape, Manning’s ‘n’ value of the channel (see Chapter 5 for procedures to determine channel ‘n’-values), and the channel slope.

| TAILWATER DATA | | |
|--------------------------|---------------------|-------|
| Channel Type | Trapezoidal Channel | |
| Bottom Width | 3.00 | ft |
| Side Slope (H:V) | 3.00 | :1 |
| Channel Slope | 0.0050 | ft/ft |
| Manning's n (channel) | 0.0650 | |
| Channel Invert Elevation | 340.70 | ft |
| Rating Curve | View... | |

Figure 6A-19
HY-8 Downstream (Regular) Channel Input Screen

Figure 6A-19 shows the HY-8 regular channel data input screen for the culvert design project. Irregular shaped channels can be input by selecting Irregular Shape in the Channel Type dialog, and providing station and elevations along a channel cross section. A tailwater rating curve is created by HY-8 in tabular format which can be plotted graphically.

Step 6:

With the tailwater rating curve developed for the downstream channel, the designer can now input the roadway data available at the culvert site. This information will be used by HY-8 to analyze roadway overtopping at the site. The roadway data input screen is shown in Figure 6A-20. The designer can enter a constant elevation when the road profile can be adequately represented as a horizontal surface. For vertical curves, the designer can define the irregular surface created by the road profile.

| ROADWAY DATA | | |
|-----------------------|----------------------------|----|
| Roadway Profile Shape | Constant Roadway Elevation | |
| First Roadway Station | 0.00 | ft |
| Crest Length | 50.00 | ft |
| Crest Elevation | 345.32 | ft |
| Roadway Surface | Paved | |
| Top Width | 30.00 | ft |

Figure 6A-20
HY-8 Roadway Data Input Screen

As seen in Figure 6A-20, the designer must provide the weir coefficient and the embankment top width (L_r , see Section 6.05.3). HY-8 provides the user with default values for paved or gravel surfaces, or the designer can enter a more appropriate value between 2.5 and 3.095. The computations for computing roadway overtopping basically

becomes a broad-crested weir problem to compute discharge over the roadway. Additional information on broad-crested weirs can be found in Section 8.05 of this Manual.

Step 7:

The designer should now verify the input data using the data summary screen. The designer can make any modifications to the data prior to running the program. The data summary screen is shown in Figure 6A-21.

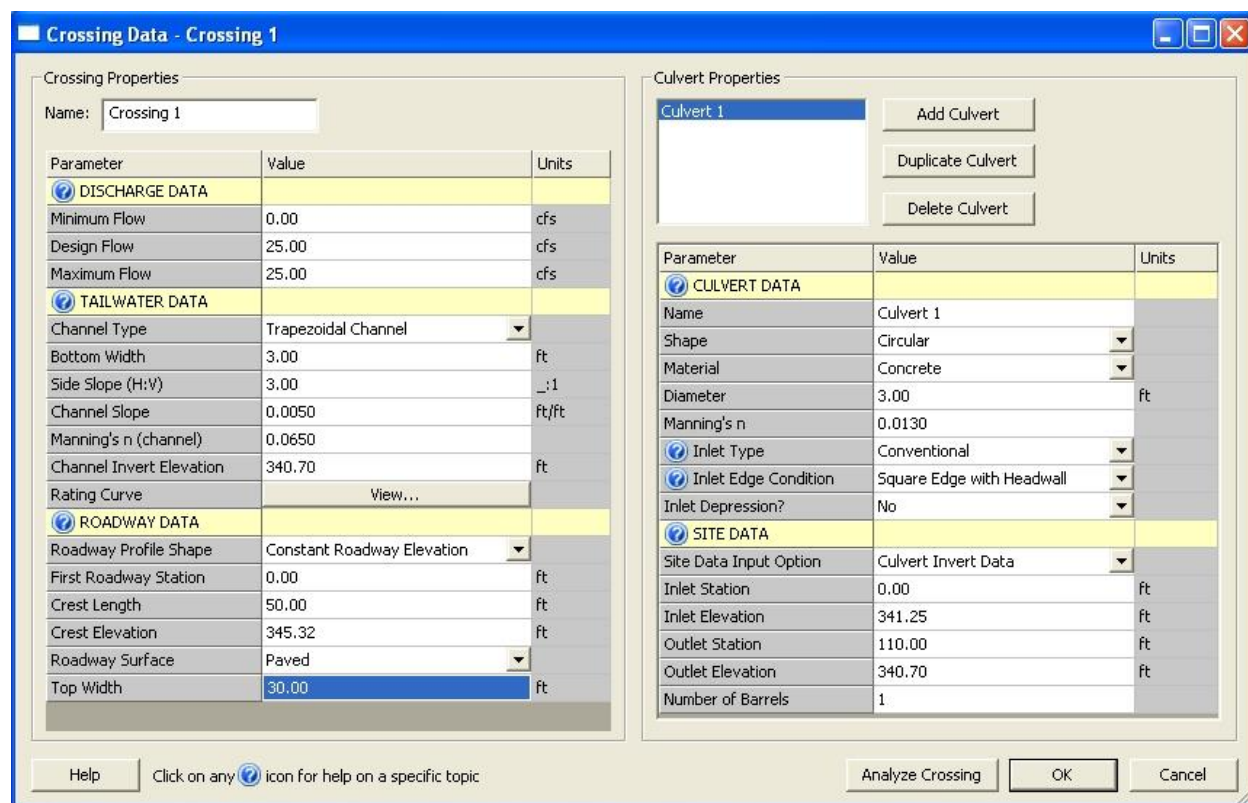

Figure 6A-21
HY-8 Data Summary Screen

6.07.2.2.2 RUN PROGRAM AND INTERPRET OUTPUT

Step 8:

With the input data now verified by the designer, the user selects "Analyze Crossing" from the main window to run the culvert computations for this site. The output screen of flow types in Figure 6A-22 is displayed below.

| Flow Type | Flow Control | Submerged Inlet | Submerged Outlet | Length Full | Loss Calc | Outlet Depth |
|-----------|--------------|-----------------|------------------|-------------|-----------|--------------|
| 1 | Inlet | No | No | None | S2n | Normal |
| 1 | Inlet | No | No | None | S1t | Tailwater |
| 1 | Inlet | No | Yes | Part | S1f | Full |
| 5 | Inlet | Yes | No | None | S2n | Normal |
| 5 | Inlet | Yes | No | None | S1t | Tailwater |
| 5 | Inlet | Yes | Yes | Part | S1f | Full |
| | | | | | | |
| 2 | Outlet | No | No | None | M2c | Critical |
| 3 | Outlet | No | No | None | M1t | Tailwater |
| 3 | Outlet | No | No | None | M2t | Tailwater |
| 3 | Outlet | No | Yes | Part | M1f | Full |
| | | | | | | |
| 4 | Outlet | Yes | Yes | All | FFf | Full |
| 6 | Outlet | Yes | No | Most | FFt | Tailwater |
| 6 | Outlet | Yes | No | Most | FFc | Critical |
| 7 | Outlet | Yes | No | Part | M1t | Tailwater |
| 7 | Outlet | Yes | No | Part | M2t | Tailwater |
| 7 | Outlet | Yes | No | Part | M2c | Critical |

Figure 6A-22
HY-8 Results Table Output Screen

Step 9:

The HY-8 output file with an .RTF or .PDF extension should be examined by the designer for accuracy. A hardcopy of the results can be viewed by selecting Create Report from the Culvert menu.

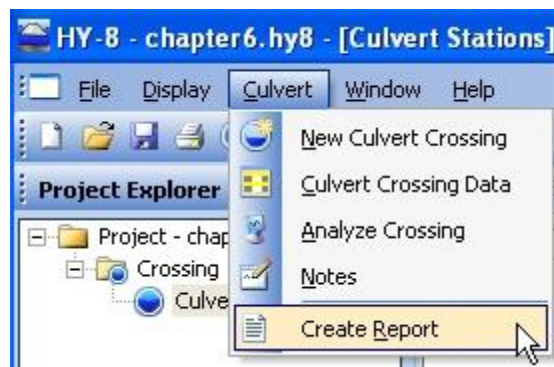

The designer can choose which fields to include in the report as shown in the dialog below. Once the designer has selected the appropriate fields, the report can be generated by selecting the OK button in the dialog below. The culvert design using HY-8 should yield similar results to the hand computations obtained in Section 6.07.2.1 (Sample Problem #1).

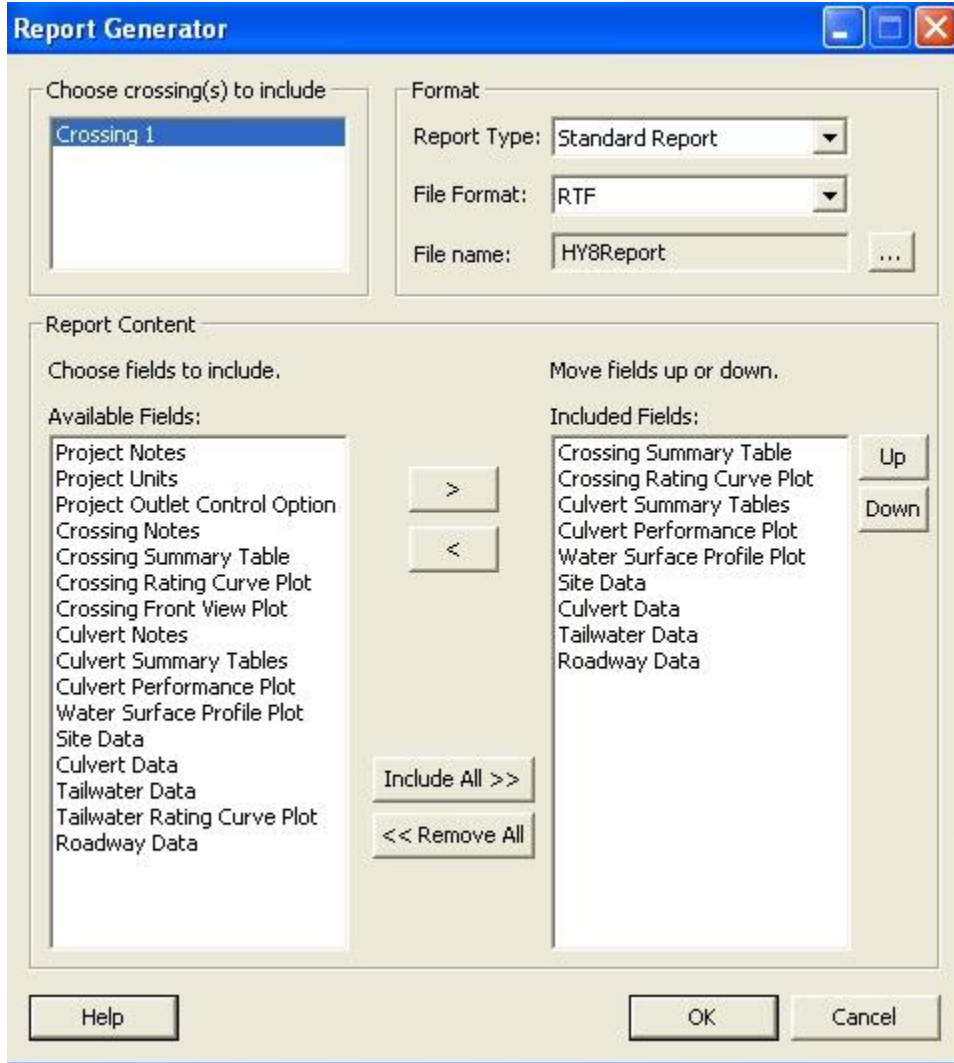

HY-8 Culvert Analysis Report

Table 1 - Summary of Culvert Flows at Crossing: Crossing 1

| Headwater Elevation (ft) | Total Discharge (cfs) | Culvert 1 Discharge (cfs) | Roadway Discharge (cfs) | Iterations |
|--------------------------|-----------------------|---------------------------|-------------------------|------------|
| 341.25 | 0.00 | 0.00 | 0.00 | 1 |
| 341.91 | 2.50 | 2.50 | 0.00 | 1 |
| 342.20 | 5.00 | 5.00 | 0.00 | 1 |
| 342.43 | 7.50 | 7.50 | 0.00 | 1 |
| 342.63 | 10.00 | 10.00 | 0.00 | 1 |
| 342.81 | 12.50 | 12.50 | 0.00 | 1 |
| 343.00 | 15.00 | 15.00 | 0.00 | 1 |
| 343.18 | 17.50 | 17.50 | 0.00 | 1 |
| 343.35 | 20.00 | 20.00 | 0.00 | 1 |
| 343.50 | 22.50 | 22.50 | 0.00 | 1 |
| 343.65 | 25.00 | 25.00 | 0.00 | 1 |

Table 2 - Culvert Summary Table: Culvert 1

| Total Discharge (cfs) | Culvert Discharge (cfs) | Headwater Elevation (ft) | Inlet Control Depth (ft) | Outlet Control Depth (ft) | Flow Type | Normal Depth (ft) | Critical Depth (ft) | Outlet Depth (ft) | Tailwater Depth (ft) | Outlet Velocity (ft/s) | Tailwater Velocity (ft/s) |
|-----------------------|-------------------------|--------------------------|--------------------------|---------------------------|-----------|-------------------|---------------------|-------------------|----------------------|------------------------|---------------------------|
| 0.00 | 0.00 | 341.25 | 0.000 | 0.000 | 0-NF | 0.000 | 0.000 | 0.000 | 0.000 | 0.000 | 0.000 |
| 2.50 | 2.50 | 341.91 | 0.659 | 0.659 | 1-S2n | 0.444 | 0.470 | 0.460 | 0.584 | 3.534 | 0.901 |
| 5.00 | 5.00 | 342.20 | 0.952 | 0.952 | 1-S2n | 0.651 | 0.688 | 0.657 | 0.833 | 4.335 | 1.092 |
| 7.50 | 7.50 | 342.43 | 1.180 | 1.180 | 1-S2n | 0.797 | 0.856 | 0.805 | 1.017 | 4.877 | 1.218 |
| 10.00 | 10.00 | 342.63 | 1.376 | 1.376 | 1-S2n | 0.934 | 0.992 | 0.941 | 1.170 | 5.294 | 1.312 |
| 12.50 | 12.50 | 342.81 | 1.561 | 1.561 | 1-S2n | 1.046 | 1.116 | 1.055 | 1.301 | 5.617 | 1.392 |
| 15.00 | 15.00 | 343.00 | 1.753 | 1.753 | 1-S2n | 1.158 | 1.232 | 1.161 | 1.417 | 5.933 | 1.460 |
| 17.50 | 17.50 | 343.18 | 1.930 | 1.930 | 1-S2n | 1.261 | 1.331 | 1.270 | 1.521 | 6.144 | 1.521 |
| 20.00 | 20.00 | 343.35 | 2.095 | 2.095 | 1-S2n | 1.359 | 1.430 | 1.360 | 1.619 | 6.417 | 1.573 |
| 22.50 | 22.50 | 343.50 | 2.252 | 2.252 | 1-S2n | 1.456 | 1.524 | 1.463 | 1.708 | 6.570 | 1.621 |
| 25.00 | 25.00 | 343.65 | 2.402 | 2.402 | 1-S2n | 1.551 | 1.607 | 1.556 | 1.791 | 6.755 | 1.667 |

 Inlet Elevation (invert): 341.25 ft, Outlet Elevation (invert): 340.70 ft
 Culvert Length: 110.00 ft, Culvert Slope: 0.0050

Figure 6A-23a
 HY-8 Output File Printout (.RTF file)

Site Data - Culvert 1

Site Data Option: Culvert Invert Data
 Inlet Station: 0.00 ft
 Inlet Elevation: 341.25 ft
 Outlet Station: 110.00 ft
 Outlet Elevation: 340.70 ft
 Number of Barrels: 1

Culvert Data Summary - Culvert 1

Barrel Shape: Circular
 Barrel Diameter: 3.00 ft
 Barrel Material: Concrete
 Barrel Manning's n: 0.0130
 Inlet Type: Conventional
 Inlet Edge Condition: Square Edge with Headwall
 Inlet Depression: None

Table 3 - Downstream Channel Rating Curve (Crossing: Crossing 1)

| Flow (cfs) | Water Surface Elev (ft) | Depth (ft) | Velocity (ft/s) | Shear (psf) | Froude Number |
|------------|-------------------------|------------|-----------------|-------------|---------------|
| 0.00 | 340.70 | 0.00 | 0.00 | 0.00 | 0.00 |
| 2.50 | 341.28 | 0.58 | 0.90 | 0.18 | 0.24 |
| 5.00 | 341.53 | 0.83 | 1.09 | 0.26 | 0.25 |
| 7.50 | 341.72 | 1.02 | 1.22 | 0.32 | 0.26 |
| 10.00 | 341.87 | 1.17 | 1.31 | 0.37 | 0.27 |
| 12.50 | 342.00 | 1.30 | 1.39 | 0.41 | 0.27 |
| 15.00 | 342.12 | 1.42 | 1.46 | 0.44 | 0.27 |
| 17.50 | 342.22 | 1.52 | 1.52 | 0.47 | 0.28 |
| 20.00 | 342.32 | 1.62 | 1.57 | 0.50 | 0.28 |
| 22.50 | 342.41 | 1.71 | 1.62 | 0.53 | 0.28 |
| 25.00 | 342.49 | 1.79 | 1.67 | 0.56 | 0.28 |

Figure 6A-23b
 HY-8 Output File Printout (.RTF file) *continued*

Tailwater Channel Data - Crossing 1

Tailwater Channel Option: Trapezoidal Channel

Bottom Width: 3.00 ft

Side Slope (H:V): 3.00 (1:1)

Channel Slope: 0.0050

Channel Manning's n: 0.0650

Channel Invert Elevation: 340.70 ft

Roadway Data for Crossing: Crossing 1

Roadway Profile Shape: Constant Roadway Elevation

Crest Length: 50.00 ft

Crest Elevation: 345.32 ft

Roadway Surface: Paved

Roadway Top Width: 30.00 ft

Figure 6A-23c
HY-8 Output File Printout (.RTF file) *continued*

6.07.2.3 EXAMPLE PROBLEM #3: CIRCULAR CULVERT WITH ROADWAY OVERTOPPING

GIVEN:

An existing 36" circular concrete culvert was designed for a 10-year storm of 25 cfs and a design headwater elevation of 344.35 feet. Upstream development has increased the 10-year runoff to approximately 80 cfs. It is expected that the roadway will be overtopped. The asphalt roadway profile can be approximated as a broad-crested weir 66 feet wide, with an overtopping elevation of 347 feet. Other pertinent site information is given as:

- Inlet invert elevation = 341.25 feet
- Existing culvert slope = 0.005 ft/ft
- Existing culvert length = 110 feet
- Entrance conditions = Type "U" endwall (square edge)
- The following flows and corresponding tailwater elevations have been computed:

| <u>Discharge (cfs)</u> | <u>Tailwater (ft)</u> |
|------------------------|-----------------------|
| 15 | 1.2 |
| 25 | 1.6 |
| 40 | 2.1 |
| 50 | 2.25 |
| 60 | 2.45 |
| 70 | 2.7 |
| 80 | 2.75 |
| 90 | 2.9 |

FIND:

Analyze the culvert for possible roadway overtopping up to a total flow of 90 ft³/s.

SOLUTION: (see Section 6.05.3)

Step 1:

The culvert performance was analyzed without considering roadway overtopping to determine the given tailwater elevations.

Step 2:

The next step for the designer will be to project an assumed HW_r onto a plot of the roadway profile to determine the weir length (L_w) over which flow will pass. Note, this is an iterative process. Each time the designer chooses a new value for HW_r, the resulting value of L_w will change. L_w will vary with differing elevations of HW_r. For the first trial, HW_r is assumed to be 0.3 feet. Projecting this value onto a plot of the roadway profile yields a value for L_w of approximately 204 feet.

Step 3:

With the roadway width (L_r) given as 66 feet, the designer should now compute the weir coefficient (C_d) for roadway overflow. The first step in this process is to compute the ratio HW_r / L_r .

$$HW_r / L_r = 0.3 / 66 = 0.0045$$

Because HW_r / L_r is less than 0.15, the designer should refer to Graph 'B' on Figure 6A-3 to obtain a value for the discharge coefficient (C_r). Entering Graph 'B' along the x-axis at the assumed value of HW_r of 0.3, and projecting vertically to the graph for paved surfaces, then projecting horizontally to the y-axis, yields a trial value of C_r equal to 3.00. Since the tailwater elevations given are below the roadway elevation, adjusting C_r for submergence utilizing Graph 'C' will not be necessary.

Step 4:

Compute the discharge over the roadway using Equation 6-11 of Section 6.05.3. With a roadway profile consisting of a vertical curve, Hw_r will need to be adjusted to account for a non-constant effective head over the weir length. This effective head will be less than the assumed HW_r . Q_r is computed as shown:

$$Q_r = (3.0)(204)[(0.65)(0.30)]^{1.5}$$

$$Q_r = 52.7 \text{ ft}^3/\text{s}$$

Where $C_r = C_d$ and, $C_e=0.65$ (constant, see Section 6.05.3)

Step 5:

Compute the flow rate through the culvert at this site using the equation:

$$Q_{\text{culv}} = Q_{\text{design}} - Q_r$$

$$Q_{\text{culv}} = 90 \text{ ft}^3/\text{s} - 52.7 \text{ ft}^3/\text{s}$$

$$Q_{\text{culv}} = 37.3 \text{ ft}^3/\text{s}$$

Step 6:

The designer should then evaluate the culvert performance (see Section 6.05.2) using the computed value of $Q_{\text{culv}} = 37.3 \text{ ft}^3/\text{s}$. Note here that Q_{culv} is not Q_{design} . Using the procedures in Section 6.05.2, the controlling headwater elevation (HW) corresponding to the computed discharge for the culvert in Step 5, was determined to be 344.55.

Step 7:

The designer should now compare the controlling headwater elevation determined for the culvert in Step 6, to the elevation corresponding to HW_r . If the two elevations are reasonably close, the analysis is finished. Otherwise, the designer must return to Step 2 and assume a new value for HW_r . In comparison, the two headwater elevations are out of an acceptable range as shown below.

$$HW_{\text{culv}} = 344.55 \quad \text{and,} \quad HW_r \text{ (assumed for trial 1)} = 347.30$$

Step 8:

Because the two headwater elevations are outside an acceptable range, Steps 2 through 7 should be repeated as necessary until the two headwater elevations are approximately equal. After assuming new values for HW_r of 0.2 and 0.1, and obtaining culvert headwater elevations higher and lower than the assumed HW_r , the designer then chooses a value of 0.16. Repeating Step 2 yields a value for L_w of 200 feet along the roadway profile.

Step 3 is repeated to obtain a value for $C_r = 2.94$ from Graph 'B' on Figure 6A-3. Solving for Q_r in Step 4 and Q_{culv} in Step 5 yields computed flow rates of 19.72 ft³/s and 72.28 ft³/s respectively. Step 6 is again repeated to obtain a culvert headwater elevation of 347.19.

Since, $HW_{\text{culv}} = 347.19$ and, $HW_r = 347.16$ are approximately equal, the design is assumed to be complete based on the level of accuracy desired.

6.07.2.4 EXAMPLE PROBLEM #4: HY- 8 IMPORVED INLET DESIGN

GIVEN:

A culvert is proposed for a new roadway crossing. The required design storm frequency is the 50-year storm event and 1 foot of freeboard is required at the roadway shoulder. The following information is known:

- 50-year flow rate (Q_{50}) = 90 ft³/s
- Invert elevation at inlet = 341.25 feet
- Invert elevation at outlet = 337.95 feet
- Natural streambed slope = 3.0% (0.03 ft/ft)
- Tailwater cross section is trapezoidal with a 4-foot bottom width and 3:1 side slopes; n-value 0.065
- Approximate culvert length = 110 feet (endwall to endwall)
- Roadway overtopping elevation = 347.00 feet
- Allowable headwater elevation = 344.32 feet
- Proposed culvert size = 36 inches

FIND:

Using a 36-inch diameter RCP, design a culvert for this site which will pass the 50-year flow rate at an acceptable headwater elevation. Use an improved inlet to maximize the capacity of the 36-inch pipe.

SOLUTION:

The full-flow capacity of a 36-inch diameter RCP at a slope of 3% is approximately 116 cfs. Thus, the pipe should have sufficient capacity if properly utilized.

Step 1:

Analyze the proposed culvert without an improved inlet to evaluate its performance. Assume that it will be provided with a Type “U” endwall, which corresponds to a “square edge with headwall” inlet condition.

Following the procedures outlined in Sample Problem #2 (Section 6.07.2.2), HY-8 results yield a headwater elevation of 347.25 feet, which is above the top of the roadway. Overtopping would begin at a discharge of about 69.2 cfs. Since this is unacceptable, and the culvert operates in inlet control, this site may be considered a candidate for an improved inlet.

Step 2:

First, try a side-tapered inlet with a face width of 6 feet and a side taper of 4:1. The first HY-8 input screen for this design is shown in Figure 6A-27. The designer should select the appropriate inlet improvement from the on-screen list. On the following screen,

the program will prompt the user for the dimensions of the improved inlet. This screen is shown in Figure 6A-28.

| | | |
|----------------------|--|----|
| CULVERT DATA | | |
| Name | Culvert 1 | |
| Shape | Circular | |
| Material | Concrete | |
| Diameter | 3.00 | ft |
| Manning's n | 0.0130 | |
| Inlet Type | Conventional | |
| Inlet Edge Condition | Conventional | |
| Inlet Depression? | Side-Tapered, Circular Side-Tapered, Rectangular Slope-Tapered | |
| SITE DATA | | |

Figure 6A-24
HY-8 Improved Inlet Selection Screen

| | | |
|-------------------------|-----------------------------------|-----|
| CULVERT DATA | | |
| Name | Culvert 1 | |
| Shape | Circular | |
| Material | Concrete | |
| Diameter | 3.00 | ft |
| Manning's n | 0.0130 | |
| Inlet Type | Side-Tapered, Rectangular | |
| Improved Inlet Edge | Square Edge Top (26-90°) Wingwall | |
| Face Width | 6.00 | ft |
| Side Taper (4:1 to 6:1) | 4.00 | ,:1 |
| Inlet Depression? | No | |

Figure 6A-25
HY-8 Side-Tapered Improved Inlet Data Screen

Step 3:

Run the program. Referring to Figure 6A-29, the resulting headwater elevation is 345.75. Although this may eliminate roadway overflow, it is still greater than the allowable elevation of 344.32. Analysis of the improved inlet performance shows that the headwater elevation would be 344.88 feet if the culvert performance were to be controlled at face section. Because the throat cross section limits the headwater to an elevation which is significantly greater than the face control elevation, it will not be possible to improve the culvert performance by modifying the side-tapered inlet.

The HY-8 output file for the proposed improved inlet analysis can be viewed by following the procedure described above in Step 9 of Example #2.

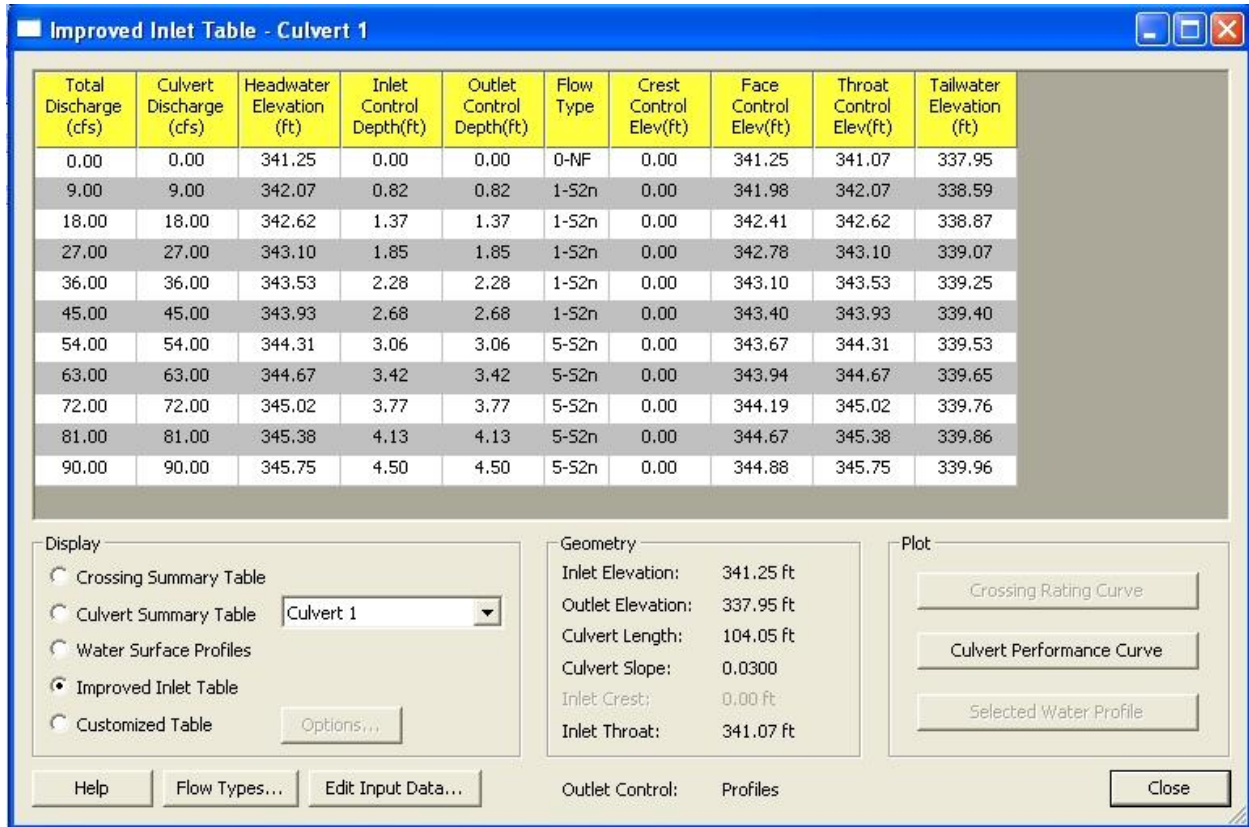

Figure 6A-26
HY-8 Side-Tapered Inlet Performance Curve Screen

Step 4:

Try a slope-tapered inlet design. The proposed inlet will have a face width of 6 feet, a side taper of 4H:1V, and a fall of 2.0 feet at a 3:1 slope. This improved inlet is further shown in Figure 6A-31. Select slope-tapered from the selection screen shown in Figure 6A-27.

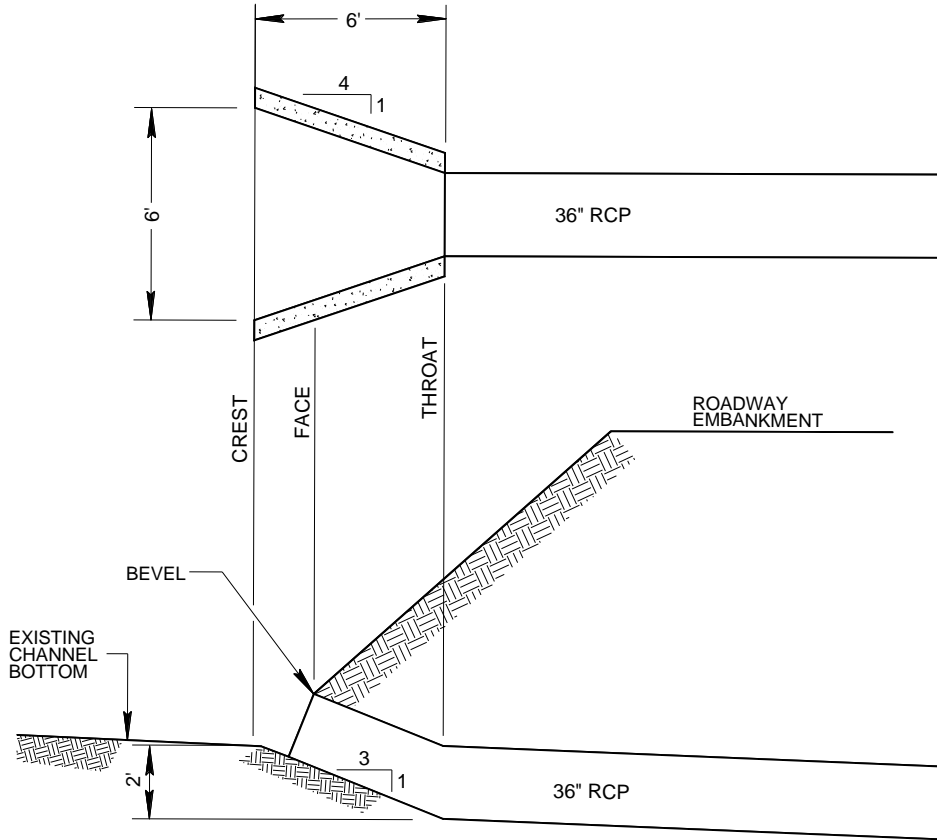

Figure 6A-27
Slope Tapered Improved Inlet Plan & Section

Step 5:

The designer will fill out the slope-tapered improved inlet data screen shown in Figure 6A-32 for the given parameters.

| Parameter | Value | Units |
|-------------------------|-----------------------------------|-------|
| CULVERT DATA | | |
| Name | Culvert 1 | |
| Shape | Circular | |
| Material | Concrete | |
| Diameter | 3.00 | ft |
| Manning's n | 0.0120 | |
| Inlet Type | Slope-Tapered | |
| Improved Inlet Edge | Square Edge Top (26-90°) Wingwall | |
| Face Width | 6.00 | ft |
| Side Taper (4:1 to 6:1) | 4.00 | :1 |
| Fall Slope (2:1 to 3:1) | 3.00 | :1 |
| Fall | 2.00 | ft |
| Mitered Face | False | |

Figure 6A-28
HY-8 Slope-Tapered Improved Inlet Data Screen

Step 6:

Run the program. HY-8 results yield a culvert headwater elevation of 344.29 feet, which is approximately equal to the given allowable headwater elevation at this site, and is therefore acceptable.

| Total Discharge (cfs) | Culvert Discharge (cfs) | Headwater Elevation (ft) | Inlet Control Depth(ft) | Outlet Control Depth(ft) | Flow Type | Crest Control Elev(ft) | Face Control Elev(ft) | Throat Control Elev(ft) | Tailwater Elevation (ft) |
|-----------------------|-------------------------|--------------------------|-------------------------|--------------------------|-----------|------------------------|-----------------------|-------------------------|--------------------------|
| 0.00 | 0.00 | 341.25 | 0.00 | 0.00 | 0-NF | 341.25 | 341.25 | 339.25 | 337.95 |
| 9.00 | 9.00 | 341.91 | 0.66 | 0.66 | 1-52n | 341.91 | 341.91 | 340.25 | 338.59 |
| 18.00 | 18.00 | 342.29 | 1.04 | 1.04 | 1-52n | 342.29 | 342.29 | 340.80 | 338.87 |
| 27.00 | 27.00 | 342.61 | 1.36 | 1.36 | 1-52n | 342.61 | 342.61 | 341.28 | 339.07 |
| 36.00 | 36.00 | 342.90 | 1.65 | 1.65 | 1-52n | 342.90 | 342.90 | 341.71 | 339.25 |
| 45.00 | 45.00 | 343.17 | 1.92 | 1.92 | 1-52n | 343.17 | 343.17 | 342.11 | 339.40 |
| 54.00 | 54.00 | 343.41 | 2.16 | 2.16 | 1-52n | 343.41 | 343.41 | 342.49 | 339.53 |
| 63.00 | 63.00 | 343.65 | 2.40 | 2.40 | 1-52n | 343.65 | 343.65 | 342.85 | 339.65 |
| 72.00 | 72.00 | 343.87 | 2.62 | 2.62 | 1-52n | 343.87 | 343.87 | 343.20 | 339.76 |
| 81.00 | 81.00 | 344.08 | 2.83 | 2.83 | 1-52n | 344.08 | 344.08 | 343.56 | 339.86 |
| 90.00 | 90.00 | 344.29 | 3.04 | 3.04 | 5-52n | 344.29 | 344.29 | 343.93 | 339.96 |

Figure 6A-29
HY-8 Slope-Tapered Performance Curve Screen

Analysis of the improved inlet performance table provided as Figure 6A-33 shows that:

- the crest control elevation = 344.29 feet
- the face control elevation = 344.29 feet
- the throat control elevation = 343.93 feet

Ideally, the crest and face control elevations should be just lower than the throat control elevation. However, that would be impractical for this situation and the above results may be considered acceptable. The HY-8 output for the proposed culvert analysis is shown in Figure 6A-34a through Figure 6A-34c on the following pages.

When examining the output data, it should be noted that the outlet velocity for this design is 17.29 ft/s, which would likely require the use of an energy dissipator as described in Chapter 9 of this Manual. Improved inlets and energy dissipators can both add significant costs to the project. Thus, the designer would want to consider whether the use of a larger culvert and a “broken-back” culvert alignment would provide a more cost-effective solution.

HY-8 Culvert Analysis Report

Table 1 - Summary of Culvert Flows at Crossing: Crossing 1

| Headwater Elevation (ft) | Total Discharge (cfs) | Culvert 1 Discharge (cfs) | Roadway Discharge (cfs) | Iterations |
|--------------------------|-----------------------|---------------------------|-------------------------|------------|
| 341.25 | 0.00 | 0.00 | 0.00 | 1 |
| 341.91 | 9.00 | 9.00 | 0.00 | 1 |
| 342.29 | 18.00 | 18.00 | 0.00 | 1 |
| 342.61 | 27.00 | 27.00 | 0.00 | 1 |
| 342.90 | 36.00 | 36.00 | 0.00 | 1 |
| 343.17 | 45.00 | 45.00 | 0.00 | 1 |
| 343.41 | 54.00 | 54.00 | 0.00 | 1 |
| 343.65 | 63.00 | 63.00 | 0.00 | 1 |
| 343.87 | 72.00 | 72.00 | 0.00 | 1 |
| 344.08 | 81.00 | 81.00 | 0.00 | 1 |
| 344.29 | 90.00 | 90.00 | 0.00 | 1 |

Table 2 - Culvert Summary Table: Culvert 1

| Total Discharge (cfs) | Culvert Discharge (cfs) | Headwater Elevation (ft) | Inlet Control Depth (ft) | Outlet Control Depth (ft) | Flow Type | Normal Depth (ft) | Critical Depth (ft) | Outlet Depth (ft) | Tailwater Depth (ft) | Outlet Velocity (ft/s) | Tailwater Velocity (ft/s) |
|-----------------------|-------------------------|--------------------------|--------------------------|---------------------------|-----------|-------------------|---------------------|-------------------|----------------------|------------------------|---------------------------|
| 0.00 | 0.00 | 341.25 | 0.000 | 0.000 | 0-NF | 0.000 | 0.000 | 0.000 | 0.000 | 0.000 | 0.000 |
| 9.00 | 9.00 | 341.91 | 0.655 | 0.655 | 1-S2n | 0.529 | 0.942 | 0.532 | 0.637 | 10.442 | 2.389 |
| 18.00 | 18.00 | 342.29 | 1.040 | 1.040 | 1-S2n | 0.755 | 1.351 | 0.761 | 0.916 | 12.654 | 2.911 |
| 27.00 | 27.00 | 342.61 | 1.363 | 1.363 | 1-S2n | 0.941 | 1.673 | 0.990 | 1.125 | 13.232 | 3.255 |
| 36.00 | 36.00 | 342.90 | 1.651 | 1.651 | 1-S2n | 1.094 | 1.944 | 1.170 | 1.296 | 14.090 | 3.520 |
| 45.00 | 45.00 | 343.17 | 1.916 | 1.916 | 1-S2n | 1.240 | 2.178 | 1.338 | 1.445 | 14.741 | 3.735 |
| 54.00 | 54.00 | 343.41 | 2.163 | 2.163 | 1-S2n | 1.372 | 2.385 | 1.498 | 1.577 | 15.310 | 3.921 |
| 63.00 | 63.00 | 343.65 | 2.398 | 2.398 | 1-S2n | 1.504 | 2.534 | 1.651 | 1.697 | 15.816 | 4.085 |
| 72.00 | 72.00 | 343.87 | 2.621 | 2.621 | 1-S2n | 1.629 | 2.678 | 1.796 | 1.807 | 16.302 | 4.228 |
| 81.00 | 81.00 | 344.08 | 2.835 | 2.835 | 1-S2n | 1.755 | 2.823 | 1.939 | 1.909 | 16.791 | 4.362 |
| 90.00 | 90.00 | 344.29 | 3.041 | 3.041 | 5-S2n | 1.883 | 2.967 | 2.072 | 2.005 | 17.290 | 4.482 |

 Inlet Elevation (invert): 341.25 ft, Outlet Elevation (invert): 337.95 ft
 Culvert Length: 110.05 ft, Culvert Slope: 0.0300
 Inlet Throat Elevation: 339.25 ft, Inlet Crest Elevation: 341.25 ft

Figure 6A-30a
 HY-8 Slope-Tapered Design Output (.RTF file)

Site Data - Culvert 1

Site Data Option: Culvert Invert Data
 Inlet Station: 0.00 ft
 Inlet Elevation: 341.25 ft
 Outlet Station: 110.00 ft
 Outlet Elevation: 337.95 ft
 Number of Barrels: 1

Culvert Data Summary - Culvert 1

Barrel Shape: Circular
 Barrel Diameter: 3.00 ft
 Barrel Material: Concrete
 Barrel Manning's n: 0.0120
 Inlet Type: Slope-Tapered
 Inlet Edge Condition: Square Edge Top (26-90°) Wingwall
 Inlet Depression: None

Table 3 - Downstream Channel Rating Curve (Crossing: Crossing 1)

| Flow (cfs) | Water Surface Elev (ft) | Depth (ft) | Velocity (ft/s) | Shear (psf) | Froude Number |
|------------|-------------------------|------------|-----------------|-------------|---------------|
| 0.00 | 337.95 | 0.00 | 0.00 | 0.00 | 0.00 |
| 9.00 | 338.59 | 0.64 | 2.39 | 1.19 | 0.61 |
| 18.00 | 338.87 | 0.92 | 2.91 | 1.72 | 0.64 |
| 27.00 | 339.07 | 1.12 | 3.25 | 2.11 | 0.65 |
| 36.00 | 339.25 | 1.30 | 3.52 | 2.43 | 0.67 |
| 45.00 | 339.40 | 1.45 | 3.73 | 2.71 | 0.68 |
| 54.00 | 339.53 | 1.58 | 3.92 | 2.95 | 0.68 |
| 63.00 | 339.65 | 1.70 | 4.08 | 3.18 | 0.69 |
| 72.00 | 339.76 | 1.81 | 4.23 | 3.38 | 0.70 |
| 81.00 | 339.86 | 1.91 | 4.36 | 3.57 | 0.70 |
| 90.00 | 339.96 | 2.01 | 4.48 | 3.75 | 0.71 |

Figure 6A-30b
 HY-8 Slope-Tapered Design Output (.RTF file) *continued*

Tailwater Channel Data - Crossing 1

Tailwater Channel Option: Trapezoidal Channel

Bottom Width: 4.00 ft

Side Slope (H:V): 3.00 (_:1)

Channel Slope: 0.0300

Channel Manning's n: 0.0650

Channel Invert Elevation: 337.95 ft

Roadway Data for Crossing: Crossing 1

Roadway Profile Shape: Constant Roadway Elevation

Crest Length: 50.00 ft

Crest Elevation: 347.00 ft

Roadway Surface: Paved

Roadway Top Width: 50.00 ft

Figure 6A-30c
 HY-8 Slope-Tapered Design Output (.RTF file) *continued*

6.07.3 GLOSSARY

The following list of terms is representative of those used in the design of culverts. All of the terms may not necessarily be used in the chapter text; but rather are commonly used by engineers, scientists, and planners.

ARCH BOX – A three-sided culvert structure which has vertical sides and an arched top.

APPURTENANCES (for a culvert) – An additional structure added to a culvert, often at the ends, to improve the functionality or safety of the pipe.

BANK SLIPPAGE – A type of erosion in a stream channel in which the sides of the channel slide down in relatively large masses.

BACKWATER – The rise of water level upstream due to a downstream obstruction or channel constriction.

BACKWATER COMPUTATION – The process by which the water surface elevations of subcritical flow in a stream reach may be calculated, using the Energy Balance Equation and an estimate of head loss in individual stream sub-reaches.

BED MATERIAL – The natural soils, rocks or other materials in which the channel of a given stream has formed.

BROAD-CRESTED WEIR – A weir which presents a significant width in the direction of flow. Water must flow a certain distance across such a weir before falling over the edge.

CHANNEL (of a stream) – A clearly defined lower portion of a natural or man-made drainage way which carries the normal flows of the stream.

CHANNEL CHANGE – The relocation of an existing stream channel to accommodate the construction of a roadway or other development.

CHANNEL FLOW – The flow of water in a defined conveyance such as a stream, ditch or pipe.

CLEAR ZONE – The total roadside border area, starting at the edge of the traveled way that is available for an errant driver to stop or regain control of a vehicle.

CLOSED CONDUIT (or PRESSURE) FLOW – Flow in a drainage structure which has a lid or other type of closed cross section which places the flow under pressure.

CONVEYANCE – A measure of the capacity of an open channel or pipe to pass water based upon its geometric and flow resistance properties.

CONTROL SECTION – The point on a water surface profile where a fixed structure or flow phenomenon determines the behavior of the profile either upstream or downstream or both.

COVER (of a pipe) – The minimum vertical distance from the outside crown of a pipe to the bottom of the roadway subgrade.

CRITICAL DEPTH – The depth at which the gravitational and inertial forces acting on the flow are exactly balanced and where the specific energy is at a minimum. For a given discharge and cross-section geometry there is only one critical depth.

CRITICAL FLOW – An open channel flow condition in which the depth is exactly at critical depth.

CROSS DRAIN – A drainage structure, usually a culvert, which conveys water from one side of a roadway to the other.

CROWN (PIPE) – The inside top of a pipe.

CULVERT – A drainage structure, usually used to convey flows through a constructed embankment, which may be considered hydraulically “long,” that is, having a span that is significantly less than its length.

D₅₀ (or d₅₀) – The effective particle size at which half of the particles in a given sample of soil or rock are smaller and half of the particles are larger.

DEBRIS – Material such as sediments, stones, tree limbs, etc. which are carried by the flow in a waterway, either by the force of the flow or by buoyancy.

DEBRIS DEFLECTOR – A structure placed in the stream channel upstream of a culvert or a bridge which acts to divert floating debris away from the entrance of the drainage facility.

DEPRESSED INLET – A culvert inlet which is lowered with respect to the grade of the natural stream channel and which is provided with a concrete or riprap transition from the stream bed to the culvert inlet.

DESIGN DISCHARGE (or FLOW RATE) – The quantity of flow, usually expressed as the number of cubic feet of water passing a given point in one second (cfs), to be accommodated by the proposed drainage facility.

DRAINAGE AREA – All of the area which will contribute runoff to a given point.

DRAINAGE EASEMENT – The right, obtained from the owner of property adjoining a roadway or other development site, to use a portion of that property to place and maintain part of a proposed drainage facility.

DROP STRUCTURE – A catch basin or manhole where at least one of the inflow pipes is at an elevation significantly above the elevation of the structure outlet pipe.

EFFECTIVE DIAMETER – The diameter of a circle which has an area equal to the flow area in a non-circular conduit or in a circular conduit flowing partly full.

ENDWALL – A concrete structure, with or without a metal grate, attached to a culvert to retain the roadway embankment fill, prevent erosion at the culvert outfall, or to enhance safety.

ENERGY DISSIPATOR – Some means, usually structural, employed at a drainage structure outfall to reduce the force or velocity of the flows leaving the structure to prevent damage by erosion.

ENERGY GRADE LINE – A line which represents the total force available in flow of water. It is a combination of energy due to the height of the water, internal pressure and velocity (pressure head + elevation head + velocity head).

ENERGY SLOPE – The slope of the energy grade line.

ENTRANCE LOSS COEFFICIENT – A number applied to the velocity head at a culvert entrance to estimate the head loss which occurs due to turbulence as water enters the culvert.

EQUALIZER PIPE – A culvert which allows the level of water ponded on both sides of a roadway or other structure to be the same. Flows in this culvert may be in either direction.

EQUIVALENT DEPTH – A parameter used to apply hydraulic equations based on a rectangular cross section to non-rectangular structures. It represents a rectangular cross section which has a width equal to twice its depth and has an area equal to the area of the flow in the non-rectangular structure.

EROSION – The removal of sediments or other soil from a site, especially by the force of moving water.

FLOODPLAIN – The total land area which would be inundated at the peak flow rate of a flood of a defined size.

FROUDE NUMBER – A parameter which represents the ratio of the inertial forces to the gravitational forces acting on a flow of water and thus indicating whether the flow is in the subcritical or the supercritical flow regime.

GRATE – An open metal lattice, made of either cast iron or structural steel, which is used to cover a stormwater inlet or culvert endwall.

GRAVITATIONAL FORCES (acting on a flow of water) – The forces which act on a body of water due to its weight which cause it to move in a downward direction.

HEAD – One of a number of different measures of the energy available in a given unit of water, including any combination of elevation, velocity and pressure.

HEAD LOSS – The reduction of available energy (as measured by the energy grade line) which occurs in the flow of water from a specified upstream point to a specified downstream point.

HEADWATER – The depth or elevation of the water surface upstream of a drainage structure, usually determined by the behavior of the flow through the structure.

HIGH WATER MARK – An indication, such a mud line or snagged debris, of the water levels created by a recent flood event.

HORIZONTAL ALIGNMENT – The location in plan of a linear structure such as a roadway, drainage structure or natural stream.

HYDRAULIC GRADE LINE – A line which represents the relative force available due to the potential energy available. This is a combination of energy due to the height of the water and internal pressure (pressure head + elevation head).

HYDRAULIC JUMP – A flow discontinuity which occurs at an abrupt transition from subcritical to supercritical flow, usually dissipating a significant amount of energy.

HYDRAULIC RADIUS – A parameter used in the analysis of uniform flow and which is computed as the flow area divided by the wetted perimeter.

HYDRAULIC PERFORMANCE (of a drainage structure) – The capacity of a given structure to convey water as measured by various parameters, including the headwater elevation and outlet flow velocity.

HYDRAULIC ROUGHNESS – The frictional resistance of a given surface to the flow of water.

IMPROVED INLET – A specialized structure placed on the upstream end of a culvert on a steep slope to improve the hydraulic performance of the culvert.

INERTIAL FORCES (acting on a flow of water) – The forces exerted on or by a body of water due to the tendency of a moving mass to continue moving in the same direction.

INLET CONTROL – A culvert flow condition in which the capacity of the entrance of the culvert determines the behavior of the flow through the culvert.

INTERNAL ROUGHNESS ELEMENTS – Blocks or other means provided upstream of a drainage structure outfall to reduce the velocity of the flow before it leaves the structure.

INVERT (or FLOW LINE) – The lowest point in a pipe or open channel.

LATERAL MIGRATION – A change in the horizontal alignment of a curved portion of a stream in which the channel moves consistently toward one side.

MANNING'S EQUATION – An empirical formula used to analyze flow conditions for a steady, uniform flow.

MANNING'S N-VALUE: - An empirical number assigned to a given material as a gage of its frictional resistance to the flow of water.

MILD SLOPE – A slope on a drainage structure or natural stream channel for which flows at normal depth for a given flow rate would be in the subcritical flow regime.

MOMENTUM – The product of mass times velocity for a flow of water.

MORPHOLOGY – The science which deals with the form of the earth, the general configuration of its surface, and the changes that take place due to erosion and sediment deposition. With regard to streams and channels, Morphology examines the processes of meandering and bed material transport, as well as the geometry of the channel cross-section.

NOMOGRAPH – A chart which provides solutions to a complex equation by means of projecting straight lines between two or more relative numeric scales.

NORMAL DEPTH – The depth of flow which will occur in an open channel of a given cross section for a given flow rate when the slope of the water surface is exactly equal to the slope of the channel.

OPEN SURFACE (GRAVITY) FLOW – A flow condition under which the water surface is open to the atmosphere and the behavior of the flow is determined only by gravity and momentum.

ORIFICE – A vertical or horizontal opening through which flows may pass and where pressure is the dominant influence over the flow rate.

OUTFALL (or OUTLET) – The point at which flows in a closed drainage system, such as a storm sewer, pass into another drainage system, usually an open conveyance such as a ditch.

OUTLET CONTROL – A culvert flow condition in which the behavior of the flow through the culvert is determined by either the capacity of the culvert barrel to pass flows or by conditions at the outlet.

OUTLET DEPTH – The depth of a flow of water at the point where it leaves a culvert or other type of closed conduit.

OVERBANK – An area above the channel of a stream which is subject to the flow of water only during flood events.

OVERTOPPING – The flow of water over a roadway or other type of embankment due to increase flows during a flood event.

PLUNGING FLOW – A flow condition which occurs at a culvert outfall where the tailwater depth is significantly less than the depth of flow in the culvert. The water surface drops suddenly at the exit, creating a significant downward component in the flow.

RIPRAP – Crushed rock, usually manufactured to a specific gradation and used to prevent erosion on slopes or in stream channels.

RIPRAP APRON – A lining composed of crushed rock placed within a waterway or other open conveyance to prevent erosion due to high-velocity flows from a drainage structure outfall.

RIPRAP STILLING BASIN – An energy dissipation structure constructed from crushed rock which provides a pool at the drainage structure outlet where a hydraulic jump may occur.

ROADWAY OVERFLOW – The quantity, depth or breadth of water which will pass over a roadway as the result of an overtopping flood event.

ROUGHNESS COEFFICIENT – A numerical measure of the frictional resistance to flow in a channel, such as the Manning's coefficient.

ROUGHNESS ELEMENTS – Structures, usually blocks, which are placed on the bottom of culvert or other type of conveyance to increase its frictional resistance to flow.

SCOUR HOLE – An eroded area which will often form due to the force of flows from the outfall of a drainage structure which has no other form of erosion protection.

SEQUENT DEPTH – The subcritical flow depth which occurs just downstream from a hydraulic jump.

SIDE DRAIN – A drainage structure, usually a culvert, which conveys water flowing in a roadway side ditch underneath driveways or other obstructions to flow.

SIDE-TAPERED INLET – An improved inlet which increases the capacity of a culvert by providing an enlarged flow area at the entrance and then tapering down to the culvert cross section.

SINUOUS – As applied to streams, indicates a curving or winding horizontal alignment.

SLOPE-TAPERED INLET – An improved inlet which increases the capacity of a culvert by providing an enlarged flow area at the entrance combined with a sloping vertical drop.

STABILITY (of a stream bed) – The degree to which the morphology of a stream bed is subject to change due to erosive forces.

STEEP SLOPE – A slope on a drainage structure or natural stream channel for which flows at normal depth for a given flow rate would be in the supercritical flow regime.

STILLING BASIN – A structure which dissipates the energy of a high-velocity flow by means of a pool into which the flow will fall, resulting in a hydraulic jump.

STOCK PASS – A structure, usually a concrete box culvert, placed under a roadway to allow the passage of livestock from one side of the road to the other.

STREAMBED DEGREDDATION – A general and consistent lowering of a stream channel due to erosive forces.

SUBCRITICAL FLOW – A flow condition in which the behavior of the flow is determined more by gravitational forces than by inertial forces.

SUPERCritical FLOW – A flow condition in which the behavior of the flow is determined more by inertial forces than by gravitational forces.

TAILWATER – Either the elevation or the depth of the water surface at the downstream end of a drainage structure, usually equivalent to the natural depth of flow in the waterway.

TAILWATER RATING CURVE – A relationship between the tailwater depth and discharge rate at the downstream end of a given structure.

TAILWATER SLOPE – The slope of the water surface or hydraulic grade line for flows downstream from a drainage structure.

TRASH RACK – A structure, often constructed of metal bars, which is placed at a storm water inlet or culvert entrance to prevent debris from entering the drainage facility.

TOP WIDTH – The distance across the water surface in an open channel flow, measured perpendicular to the channel.

VELOCITY HEAD – The energy in a flow of water due to its motion (kinetic energy). It is normally computed as the square of the velocity divided by twice the acceleration of gravity.

VERTICAL ALIGNMENT – The elevations or location in profile of a linear structure such as a roadway, drainage structure or natural stream.

WATERSHED – (see *Drainage Area*).

WEIR – A ridge or raised sill over which flows may freely fall so that gravity is the dominant influence over the flow rate.

6.07.4 REFERENCES

U.S. Department of Transportation, Federal Highway Administration. *Hydraulics of Bridge Waterways*. Second Edition, Hydraulics Design Series No. 1 (HDS-1), Washington, D.C. September 1973.

U.S. Department of Transportation, Federal Highway Administration. *Introduction to Highway Hydraulics*. Hydraulics Design Series No. 4 (HDS-4), Publication No. FHWA NHI 01-019. Washington, D.C. August 2001.

U.S. Department of Transportation, Federal Highway Administration. *Hydraulic Design of Highway Culverts*. Hydraulic Design Series No. 5 (HDS-5). FHWA-IP-85-15, Washington, D.C. September 1985.

U.S. Department of Transportation, Federal Highway Administration. *HY-8 Culvert Analysis Microcomputer Program, Applications Guide*. FHWA-EPD-87-101, Hydraulic Microcomputer Program HY8. Washington, D.C. May 1987.

U.S. Department of Transportation, Federal Highway Administration. *Hydraulic Charts for the Selection of Highway Culverts*. Hydraulic Engineering Circular No. 5 (HEC-5). Washington, D.C. December 1965.

U.S. Department of Transportation, Federal Highway Administration. *Debris Control Structures*. Hydraulic Engineering Circular No. 9 (HEC-9). Washington, D.C. March 1971.

U.S. Department of Transportation, Federal Highway Administration. *Capacity Charts for the Hydraulic Design of Highway Culverts*. Hydraulic Engineering Circular No. 10 (HEC-10). Washington, D.C. November 1972.

U.S. Department of Transportation, Federal Highway Administration. *Hydraulic Flow Resistance Factors for Corrugated Metal Conduits*. Report No. FHWA-TS-80-216. Washington, D.C., 1980.

U.S. Department of Transportation, Federal Highway Administration. *Hydraulic Design of Improved Inlets for Culverts*. Hydraulic Engineering Circular No. 13 (HEC-13), Publication No. FHWA EO-72-13. Washington, D.C. August 1972.

U.S. Department of Transportation, Federal Highway Administration. *Hydraulic Design of Energy Dissipators for Culverts and Channels*. Hydraulic Engineering Circular No. 14 (HEC-14), Publication No. FHWA EP-86-110. Washington, D.C. September 1983.

U.S. Department of Transportation, Federal Highway Administration. *Hydraulic Design of Energy Dissipators for Culverts and Channels*. Hydraulic Engineering Circular No. 14 (HEC-14), Publication No. FHWA NHI-06-086. Washington, D.C. July 2006.

U.S. Department of Transportation, Federal Highway Administration. *Structural Design Manual for Improved Inlets and Culverts*. FHWA Publication No. FHWA IP-83-6. Washington, D.C. June 1983.

U.S. Department of Agriculture, Soil Conservation Service (SCS). National Engineering Handbook (NEH), Section 5. Hydraulics. 1956.

Hankins, Jr., A.L. *Guidelines for Drainage Studies and Hydraulic Design*. North Carolina Department of Transportation. Raleigh, NC. 1999.

Indiana Department of Transportation. *Indiana Design Manual Part IV Volume I*. Indianapolis, Indiana. 1999.

Kansas Department of Transportation. *Report Number K-TRAN KU-93-5: Development of Hydraulic Design Charts for Type IV End Sections for Pipe Culverts*. Topeka, Kansas. 1993.

Metropolitan Government of Nashville and Davidson County Department of Public Works Engineering Division. *Stormwater Management Manual*. Nashville, Tennessee. July 1988.

Tennessee Department of Transportation, Design Division, *Roadway Design Guidelines - English*. Nashville, TN. May, 2012.

Texas Department of Transportation, *Hydraulic Design Manual*. November 2002.

Virginia Department of Transportation. Location and Design Division. *Drainage Manual*. Richmond, Virginia. April 2002.

American Association of State Highway and Transportation Officials. *Model Drainage Manual*. [Metric Edition]. Washington, D.C. 1999.

Brater, Ernest; King, Horace; Lindell, James; Wei, C.Y.; *Handbook of Hydraulics*, 7th ed., McGraw Hill Book Company, Inc., 1996.

American Concrete Pipe Association. *Concrete Pipe Design Manual*. Vienna, Virginia. 1978.

American Concrete Pipe Association. *Concrete Pipe Handbook*. Vienna, Virginia. 1980.

Chow, V.T., ed., 1959. *Open Channel Hydraulics*. McGraw Hill Book Company, Inc., New York.

6.07.5 ABBREVIATIONS

AASHTO – American Association of State Highway and Transportation Officials
 ADT - Average Daily Traffic
 CMP - Corrugated Metal Pipe
 DTM - Digital Terrain Modeling
 EPA - U.S. Environment Protection Agency
 FEMA - Federal Emergency Management Agency
 FHWA - Federal Highway Administration
 HDS-1 - Hydraulic Design Series Number 1
 HDS-3 - Hydraulic Design Series Number 3
 HDS-4 - Hydraulic Design Series Number 4
 HDS-5 - Hydraulic Design Series Number 5
 HEC-5 - Hydraulic Engineering Circular Number 5
 HEC-9 - Hydraulic Engineering Circular Number 9
 HEC-10 - Hydraulic Engineering Circular Number 10
 HEC-11 - Hydraulic Engineering Circular Number 11
 HEC-13 - Hydraulic Engineering Circular Number 13
 HEC-14 - Hydraulic Engineering Circular Number 14
 HEC-20 - Hydraulic Engineering Circular Number 20
 HEC-RAS - Hydrologic Engineering Center River Analysis System
 HDPE – High Density Polyethylene Pipe
 HW - Headwater
 NEH-5 - National Engineering Handbook Number 5
 PP – Polypropylene Pipe
 PVC – Polyvinyl Chloride
 RCP - Reinforced Concrete Pipe
 SRTRP – Steel Reinforced Thermoplastic Ribbed Pipe
 TDOT - Tennessee Department of Transportation
 TDEC - Tennessee Department of Environment and Conservation
 TW - Tailwater
 USDA - United States Department of Agriculture
 USDOT - United States Department of Transportation
 USGS - United States Geological Survey